

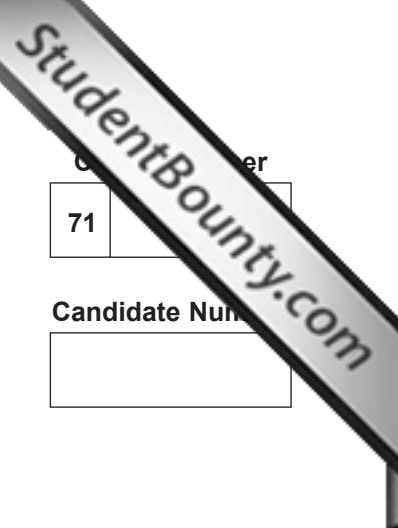

Rewarding Learning

ADVANCED
General Certificate of Education
2011



Centre Number
71

Candidate Number
[]

Biology

Assessment Unit A2 2

assessing

Biochemistry, Genetics and Evolutionary Trends

[AB221]



THURSDAY 26 MAY, AFTERNOON

TIME

2 hours.

INSTRUCTIONS TO CANDIDATES

Write your Centre Number and Candidate Number in the spaces provided at the top of this page.
Write your answers in the spaces provided in this question paper.
There is an extra lined page at the end of the paper if required.
Answer **all eight** questions.

INFORMATION FOR CANDIDATES

The total mark for this paper is 90.
Section A carries 72 marks. Section B carries 18 marks.
Figures in brackets printed down the right-hand side of pages indicate the marks awarded to each question or part question.
You are reminded of the need for good English and clear presentation in your answers.
Use accurate scientific terminology in all answers.
You should spend approximately **25 minutes** on Section B.
You are expected to answer Section B in continuous prose.
Quality of written communication will be assessed in **Section B**, and awarded a maximum of 2 marks.

Statistics sheets are provided for use with this paper.

For Examiner's use only	
Question Number	Marks
1	
2	
3	
4	
5	
6	
7	
8	

Total Marks	
--------------------	--

BLANK PAGE

Section A

1 The diagram below represents transverse sections through three different animal phyla, **A**, **B** and **C**.

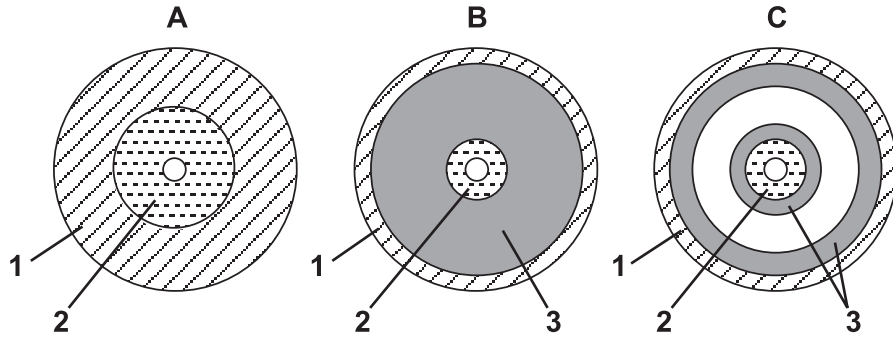

(a) Identify the body layers 1, 2 and 3.

1 _____
 2 _____
 3 _____

[3]

(b) Identify which of the transverse sections (**A**, **B** or **C**) represents a member of the phylum Platyhelminthes. Give **one** reason for your decision.

Section _____

Reason _____

[2]

(c) Which section (**A**, **B** or **C**) represents a phylum that shows radial symmetry?

[1]

(d) Which section (**A**, **B** or **C**) represents a phylum in which chaetae would be present?

[1]

2 (a) Glycerate phosphate and triose phosphate are produced during the light-independent stage of photosynthesis.

(i) The light-independent stage is sometimes referred to as the 'dark stage'. Explain why light-independent is a more appropriate term.

_____ [1]

(ii) State the precise location of the light-independent stage.

_____ [1]

(iii) The graph below shows the concentrations of glycerate phosphate and triose phosphate during periods of light and dark.

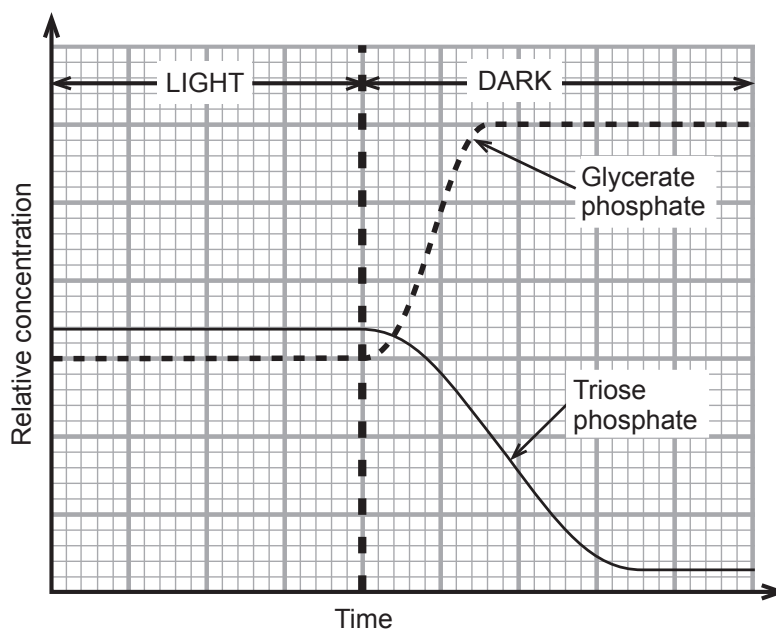

Explain the change in the concentration of triose phosphate, when light is no longer available, as shown in the graph above.

_____ [3]

(b) The diagram below shows the absorption spectrum for the photosynthetic pigments in a typical terrestrial plant.

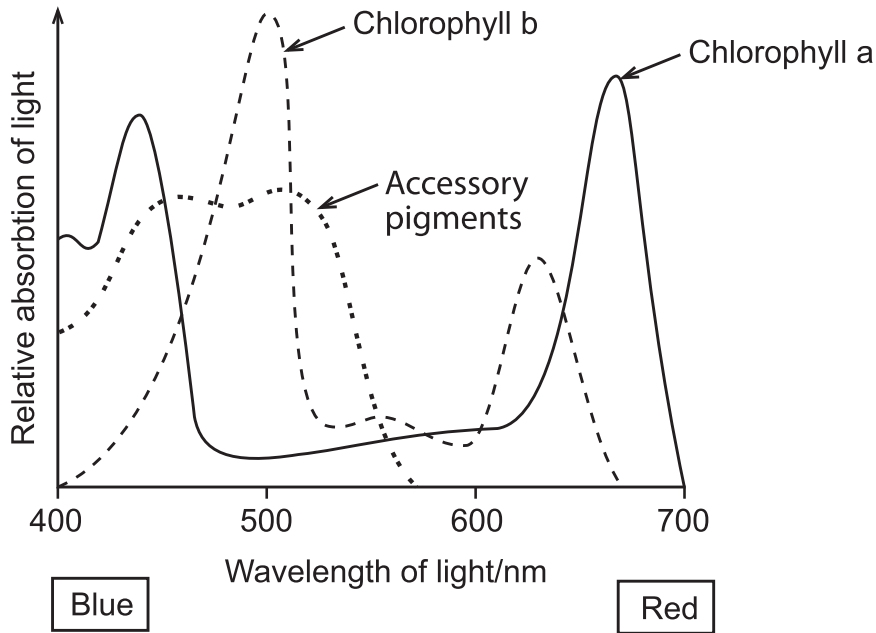

The action spectrum is distinct from the absorption spectrum. Explain what is meant by the term 'action spectrum'.

[1]

(c) White light is composed of different wavelengths. Light filters can be used to control the wavelengths of light reaching a plant.

Devise a plan for an experiment to compare the rates of photosynthesis of a water plant in red and blue light. Your plan should refer to the control of variables, the collection of data and the determination of photosynthetic rate.

[4]

3 (a) The diagram below shows part of the process of aerobic respiration.

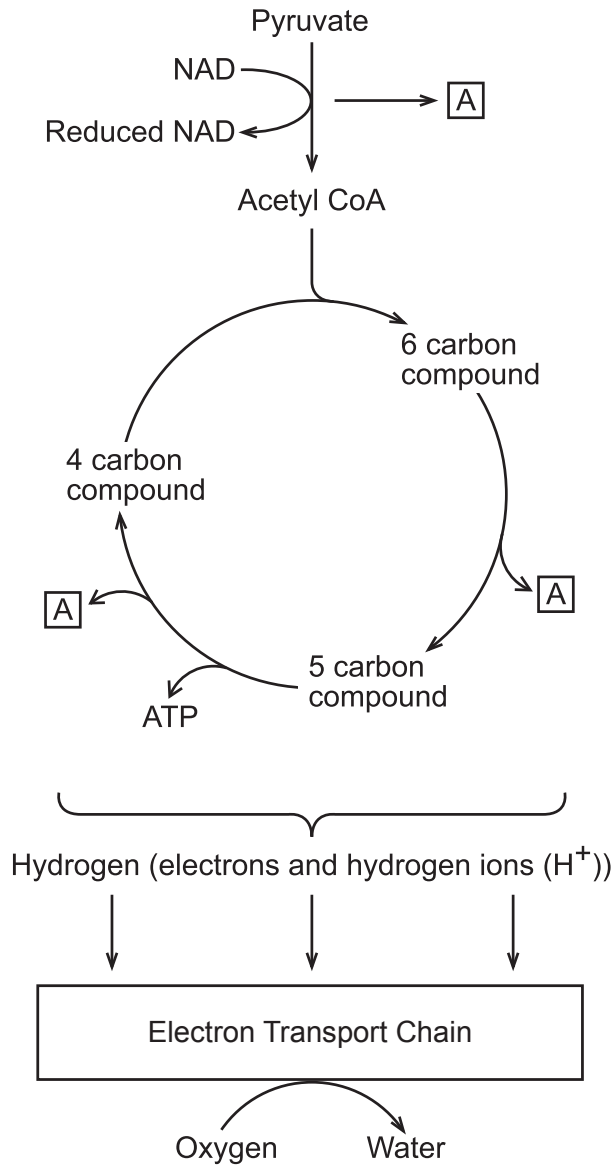

(i) Name the respiratory process that produces pyruvate.

_____ [1]

(ii) Name molecule A.

_____ [1]

(iii) State the precise location of the electron transport chain.

_____ [1]

(iv) Explain how ATP is produced in the electron transport chain.

[4]

(b) An investigation into the respiratory quotient (RQ) of yeast cells under different conditions was undertaken. The resulting RQ values are shown in the table below.

Identify the missing 'respiratory substrate(s)' and 'type(s) of respiration' and complete the table.

RQ value	Respiratory substrate(s)	Type(s) of respiration
0.68		aerobic
0.84	mixed	aerobic
1.24	carbohydrate	

[2]

4 The diagram below shows a step in the synthesis of a polypeptide during translation.

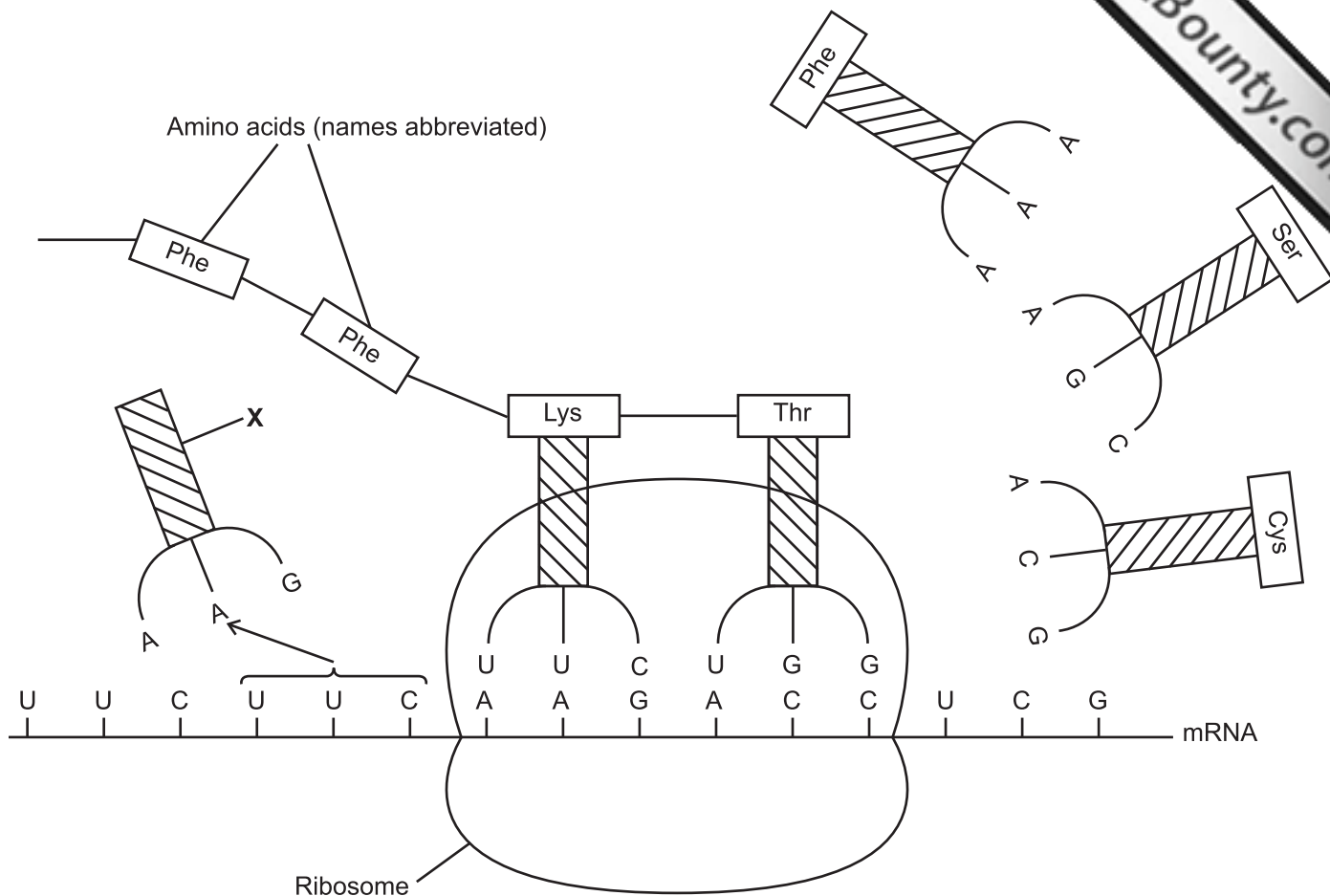

(a) Name molecule X.

_____ [1]

(b) Using the information in the diagram describe precisely what happens in the next step of polypeptide synthesis.

_____ [4]

Examiner Only	
Marks	Remark

(c) The genetic code is described as degenerate. Explain what is meant by the term 'degenerate' and identify where in the diagram a degenerate code is illustrated.

[2]

(d) Different types of mutation can arise which cause a change in the genetic code. A base deletion can have much more significant consequences in terms of the final protein produced than a base substitution which may have little or no effect. Explain the reasons for this.

[3]

BLANK PAGE

5 In fruit flies of the genus *Drosophila*, the allele for normal wings, **A**, is dominant to the allele for vestigial wing, **a**. The allele for normal body colour, **B**, is dominant to the allele for ebony body, **b**.

(a) (i) Flies with vestigial wings and heterozygous for normal body colour were crossed.

State the parental genotypes and possible gametes produced.

Parental phenotypes	vestigial wings normal body	vestigial wings normal body
----------------------------	--------------------------------	--------------------------------

Parental genotypes	_____	_____
---------------------------	-------	-------

Gametes	_____	_____
----------------	-------	-------

Complete a genetic cross to show the genotypes and phenotypes of the offspring.

[4]

(ii) During which stage in the production of gametes does Mendel's Second Law (the Law of Independent Assortment) apply?

_____ [1]

(b) The numbers of offspring produced from another cross were recorded.

- normal body, normal wing 471
- normal body, vestigial wing 519
- ebony body, normal wing 479
- ebony body, vestigial wing 531

A total of 2000 flies were produced.

The chi squared test can be used to check if these results statistically fit an expected ratio of 1:1:1:1.

(i) Suggest a suitable null hypothesis for this test.

_____ [1]

(ii) Complete the table below and calculate the χ^2 value for these results.

Category	Observed (O)	Expected (E)	(O - E)	(O - E) ²	$\frac{(O - E)^2}{E}$
Normal body normal wing	471				
Normal body vestigial wing	519				
Ebony body normal wing	479				
Ebony body vestigial wing	531				

Calculated χ^2 value _____ [2]

(iii) On the basis of your calculated χ^2 value, state the following.

- the degrees of freedom for the test _____
- the probability value _____
- your decision about the null hypothesis _____

[3]

(iv) Explain the outcome of your statistical test.

_____ [1]

(c) In an isolated colony of *Drosophila* on an offshore island, it was found that 176 *Drosophila* had vestigial wings and 924 had normal wings.

(i) Using the Hardy–Weinberg equation, calculate the number of *Drosophila* expected to be heterozygous for normal wings.

Answer _____ [3]

(ii) Certain conditions must be met in order to apply the Hardy–Weinberg equation. State **one** way in which this *Drosophila* population met these conditions.

_____ [1]

- 6 (a) The pedigree diagram below shows the incidence of cystic fibrosis in a family. Cystic fibrosis is a recessive autosomal condition.

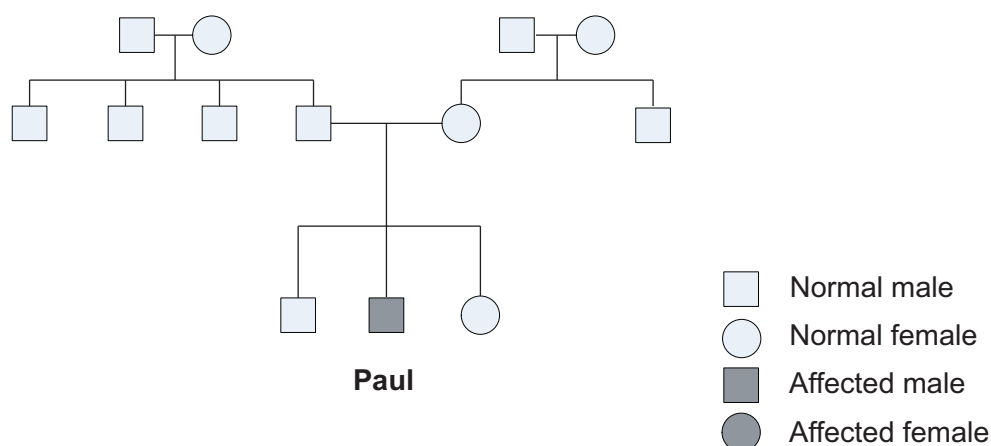

- (i) Ignoring the possibility of a recent mutation, explain the genetic basis for Paul having cystic fibrosis. Your answer should relate to the two earlier generations.

[2]

- (ii) Cystic fibrosis results in a thick, sticky mucus accumulating in the lung passages as a consequence of the malfunctioning of the surrounding respiratory passage cells. This makes patients more prone to infection.

Research is ongoing into the use of gene therapy to treat cystic fibrosis. One technique is to use aerosols to spray normal alleles (within liposomes) into the respiratory passages. The normal alleles provide normal functioning but do not become integrated into the host cell's DNA. Another technique involves the use of viruses as vectors to enable the normal alleles to gain entrance to cells.

The use of gene therapy in treating cystic fibrosis highlights issues surrounding somatic cell gene therapy in general, since it is difficult to modify genes in an already developed organism. Therefore, while gene therapy has huge potential it is still of limited use as a successful treatment.

Using cystic fibrosis as an example, give **three** reasons why the technique of gene therapy is of limited use.

1. _____

 2. _____

 3. _____

- [3]

(b) The transfer of genes from one organism to another produces genetically modified organisms (GMOs). However, the production of GMOs involves certain risks and, in order to reduce these risks, a number of safety precautions have been devised. Describe **two** safety precautions used to reduce the risks involved in the production of GMOs.

1. _____

 2. _____

- [2]

(c) Human genome sequencing raises the possibility of producing 'designer drugs'.

(i) Define the term 'genome'.

_____ [1]

(ii) Explain what is meant by a 'designer drug'.

_____ [1]

7 *Allium ursinum* (wild garlic) is a common plant found throughout damper areas of the British Isles.

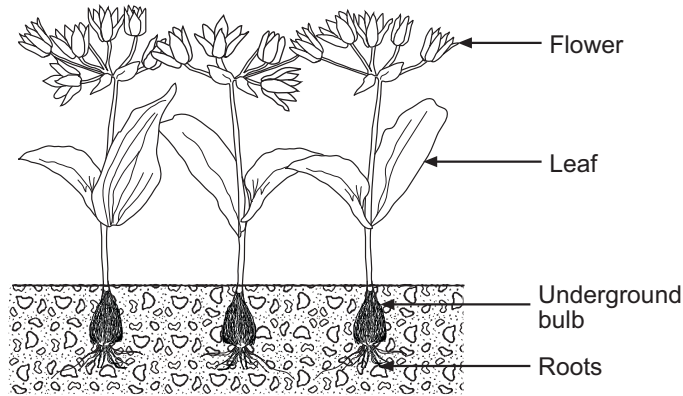

(a) An investigation was carried out to determine if leaf size in wild garlic was associated with soil nitrate levels. Measurements were taken of the length and width of leaves at various sites in Northern Ireland along with soil nitrate levels. Fifty leaves were measured at each site and the mean values calculated.

The scattergrams below show the results. (Two of the sites investigated, Ballinderry and Marble Arch, are identified on the graphs – these relate to sub-part (ii) of the question.)

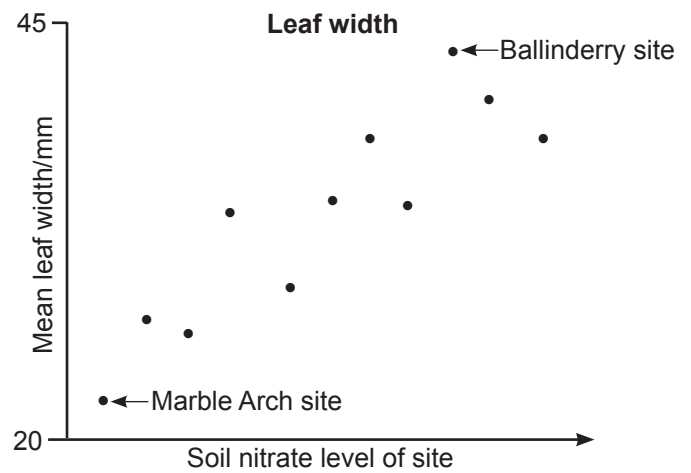
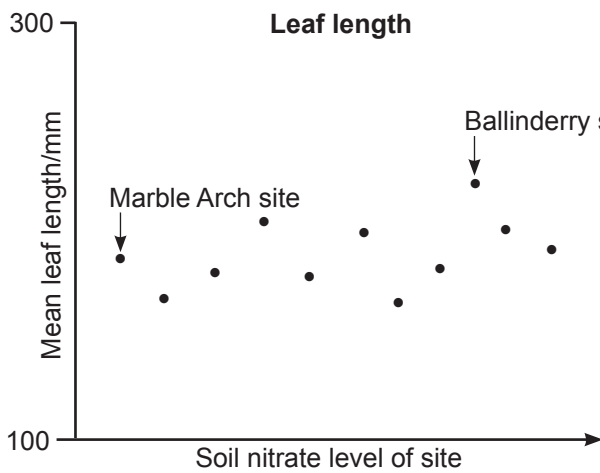

(i) Describe the trend shown by each of the above scattergrams.

[2]

--	--

There is an obvious difference in the mean leaf width of the plants in Ballinderry and Marble Arch. An experiment was devised to investigate the relative contributions of the genotype and the environment in determining this difference. Seeds from wild garlic plants in Ballinderry and Marble Arch were collected and planted in an experimental garden, where soil nitrate levels were controlled and kept constant.

After a number of years, when the plants in the experimental garden had reached maturity, 50 leaves from each site of origin were sampled and their width measured. The graph below shows these results along with the results of mean leaf width in the natural habitats.

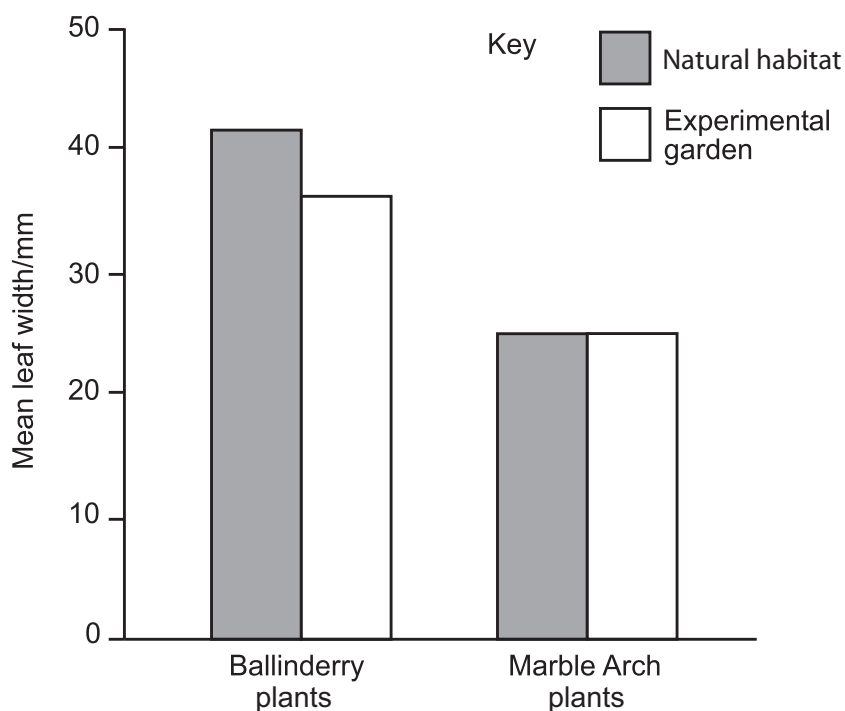

(ii) Using the information provided, state whether the difference in leaf width between the two sites is mainly genetic or environmental. Explain your answer.

[2]

(b) Discuss how mosses, ferns and flowering plants are differently adapted for life on land.

Permission to reproduce all copyright material has been applied for.
In some cases, efforts to contact copyright holders may have been unsuccessful and CCEA
will be happy to rectify any omissions of acknowledgement in future if notified.



ADVANCED
General Certificate of Education

Biology
Statistical Formulae and Tables

Statistics Sheets

Statistical Formulae and Tables

1 Definition of Symbols

n = sample size

\bar{x} = sample mean

$\hat{\sigma}$ = estimate of the standard deviation

These parameters are obtained using a calculator with statistical functions, remembering to use the function for $\hat{\sigma}$ – which may be designated a different symbol on the calculator – with $(n - 1)$ denominator.

2 Practical Formulae

2.1 Estimation of the standard deviation (error) of the mean ($\hat{\sigma}_{\bar{x}}$)

$$\hat{\sigma}_{\bar{x}} = \sqrt{\frac{\hat{\sigma}^2}{n}}$$

2.2 Confidence limits for population mean

$$\bar{x} \pm t \sqrt{\frac{\hat{\sigma}^2}{n}}$$

which can be rewritten, in terms of $\hat{\sigma}_{\bar{x}}$, as

$$\bar{x} \pm t(\hat{\sigma}_{\bar{x}})$$

where t is taken from t tables for the appropriate probability and $n - 1$ degrees of freedom.

3 Tests of significance

3.1 Student's t test

Different samples are denoted by subscripts; thus, for example, \bar{x}_1 and \bar{x}_2 are the sample means of sample 1 and sample 2 respectively.

The following formula for t is that to be used:

$$t = \frac{\bar{x}_1 - \bar{x}_2}{\sqrt{\frac{\hat{\sigma}_1^2}{n_1} + \frac{\hat{\sigma}_2^2}{n_2}}}$$

which can be rewritten, in terms of $\hat{\sigma}_{\bar{x}}$, as

$$t = \frac{\bar{x}_1 - \bar{x}_2}{\sqrt{\hat{\sigma}_{\bar{x}_1}^2 + \hat{\sigma}_{\bar{x}_2}^2}}$$

with $n_1 + n_2 - 2$ degrees of freedom.

3.2 Chi squared test

Using the symbols O = observed frequency, E = expected frequency and Σ = the sum of

$$\chi^2 = \Sigma \frac{(O - E)^2}{E}$$

with $n - 1$ degrees of freedom (where n is the number of categories).

Table 1 Student's t values

d.f.	$p = 0.1$	0.05	0.02	0.01	0.002	0.001
1	6.314	12.706	31.821	63.657	318.31	636.62
2	2.920	4.303	6.965	9.925	22.327	31.598
3	2.353	3.182	4.541	5.841	10.214	12.924
4	2.132	2.776	3.747	4.604	7.173	8.610
5	2.015	2.571	3.365	4.032	5.893	6.869
6	1.943	2.447	3.143	3.707	5.208	5.959
7	1.895	2.365	2.998	3.499	4.785	5.408
8	1.860	2.306	2.896	3.355	4.501	5.041
9	1.833	2.262	2.821	3.250	4.297	4.781
10	1.812	2.228	2.764	3.169	4.144	4.587
11	1.796	2.201	2.718	3.106	4.025	4.437
12	1.782	2.179	2.681	3.055	3.930	4.318
13	1.771	2.160	2.650	3.012	3.852	4.221
14	1.761	2.145	2.624	2.977	3.787	4.140
15	1.753	2.131	2.602	2.947	3.733	4.073
16	1.746	2.120	2.583	2.921	3.686	4.015
17	1.740	2.110	2.567	2.898	3.646	3.965
18	1.734	2.101	2.552	2.878	3.610	3.922
19	1.729	2.093	2.539	2.861	3.579	3.883
20	1.725	2.086	2.528	2.845	3.552	3.850
21	1.721	2.080	2.518	2.831	3.527	3.819
22	1.717	2.074	2.508	2.819	3.505	3.792
23	1.714	2.069	2.500	2.807	3.485	3.767
24	1.711	2.064	2.492	2.797	3.467	3.745
25	1.708	2.060	2.485	2.787	3.450	3.725
26	1.706	2.056	2.479	2.779	3.435	3.707
27	1.703	2.052	2.473	2.771	3.421	3.690
28	1.701	2.048	2.467	2.763	3.408	3.674
29	1.699	2.045	2.462	2.756	3.396	3.659
30	1.697	2.042	2.457	2.750	3.385	3.646
40	1.684	2.021	2.423	2.704	3.307	3.551
60	1.671	2.000	2.390	2.660	3.232	3.460
120	1.658	1.980	2.358	2.617	3.160	3.373
∞	1.645	1.960	2.326	2.576	3.090	3.291

© *Introductory Statistics for Biology second edition Studies in Biology No43* by R E Parker, published by Edward Arnold (Publishers) Ltd, 1991. Reproduced by permission of Cambridge University Press

Table 2 χ^2 values

d.f.	$p = 0.900$	0.500	0.100	0.050	0.010	0.001
1	0.016	0.455	2.71	3.84	6.63	10.83
2	0.211	1.39	4.61	5.99	9.21	13.82
3	0.584	2.37	6.25	7.81	11.34	16.27
4	1.06	3.36	7.78	9.49	13.28	18.47
5	1.61	4.35	9.24	11.07	15.09	20.52
6	2.20	5.35	10.64	12.59	16.81	22.46
7	2.83	6.35	12.02	14.07	18.48	24.32
8	3.49	7.34	13.36	15.51	20.09	26.13
9	4.17	8.34	14.68	16.92	21.67	27.88
10	4.87	9.34	15.99	18.31	23.21	29.59
11	5.58	10.34	17.28	19.68	24.73	31.26
12	6.30	11.34	18.55	21.03	26.22	32.91
13	7.04	12.34	19.81	22.36	27.69	34.53
14	7.79	13.34	21.06	23.68	29.14	36.12
15	8.55	14.34	22.31	25.00	30.58	37.70
16	9.31	15.34	23.54	26.30	32.00	39.25
17	10.09	16.34	24.77	27.59	33.41	40.79
18	10.86	17.34	25.99	28.87	34.81	42.31
19	11.65	18.34	27.20	30.14	36.19	43.82
20	12.44	19.34	28.41	31.41	37.57	45.32
21	13.24	20.34	29.62	32.67	38.93	46.80
22	14.04	21.34	30.81	33.92	40.29	48.27
23	14.85	22.34	32.01	35.17	41.64	49.73
24	15.66	23.34	33.20	36.42	42.98	51.18
25	16.47	24.34	34.38	37.65	44.31	52.62
26	17.29	25.34	33.56	38.89	45.64	54.05
27	18.11	26.34	36.74	40.11	46.96	55.48
28	18.94	27.34	37.92	41.34	48.28	56.89
29	19.77	28.34	39.09	42.56	49.59	58.30
30	20.60	29.34	40.26	43.77	50.89	59.70
40	29.05	39.34	51.81	55.76	63.69	73.40
50	37.69	49.33	63.17	67.50	76.15	86.66
60	46.46	59.33	74.40	79.08	88.38	99.61
70	55.33	69.33	85.53	90.53	100.43	112.32
80	64.28	79.33	96.58	101.88	112.33	124.84
90	73.29	89.33	107.57	113.15	124.12	137.21
100	82.36	99.33	118.50	123.34	135.81	149.45

© *Introductory Statistics for Biology second edition Studies in Biology No43* by R E Parker, published by Edward Arnold (Publishers) Ltd, 1991. Reproduced by permission of Cambridge University Press

