



Rewarding Learning

ADVANCED  
General Certificate of Education  
2012

---

## Mathematics

Assessment Unit M4  
*assessing*  
Module M4: Mechanics 4  
[AMM41]



FRIDAY 22 JUNE, AFTERNOON

---

### TIME

1 hour 30 minutes.

### INSTRUCTIONS TO CANDIDATES

Write your Centre Number and Candidate Number on the Answer Booklet provided.  
Answer **all six** questions.  
Show clearly the full development of your answers.  
Answers should be given to three significant figures unless otherwise stated.  
You are permitted to use a graphic or scientific calculator in this paper.

### INFORMATION FOR CANDIDATES

The total mark for this paper is 75  
Figures in brackets printed down the right-hand side of pages indicate the marks awarded to each question or part question.  
Answers should include diagrams where appropriate and marks may be awarded for them.  
Take  $g = 9.8 \text{ m s}^{-2}$ , unless specified otherwise.  
A copy of the **Mathematical Formulae and Tables booklet** is provided.  
Throughout the paper the logarithmic notation used is  $\ln z$  where it is noted that  $\ln z \equiv \log_e z$



**Answer all six questions.**

**Show clearly the full development of your answers.**

**Answers should be given to three significant figures unless otherwise stated.**

- 1 (a) ABC is a framework of three light pin jointed rods freely hinged to a rigid support at B. The framework supports a weight of 30 N at C. It is held in equilibrium with BC horizontal by a force  $P$  acting at A in the direction CA as shown in Fig. 1 below.

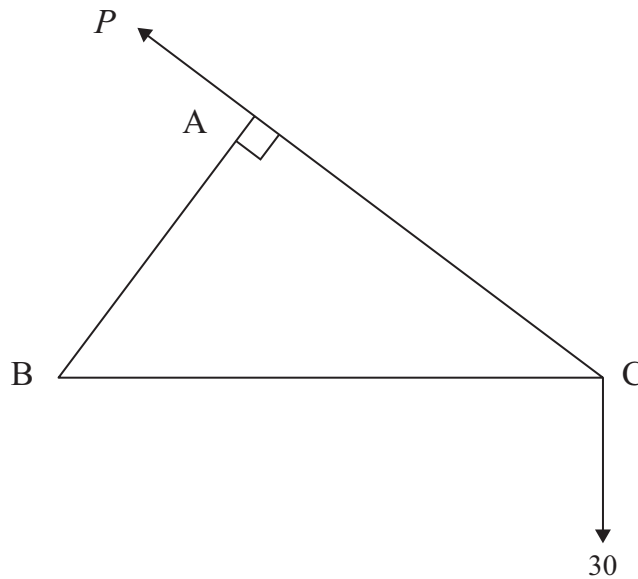

**Fig. 1**

$$AB = 0.3 \text{ m} \quad AC = 0.4 \text{ m} \quad BC = 0.5 \text{ m}$$

- (i) Find  $P$ . [3]
- (ii) Explain why there is no force in AB. [1]
- (iii) Find the internal forces in the rods AC and BC. [3]

(b) Fig. 2 below shows a scalene quadrilateral ABCD with  
AB = 0.9m    BC = 1.2m    CD = 0.8m    DA = 1.7m    AC = 1.5m

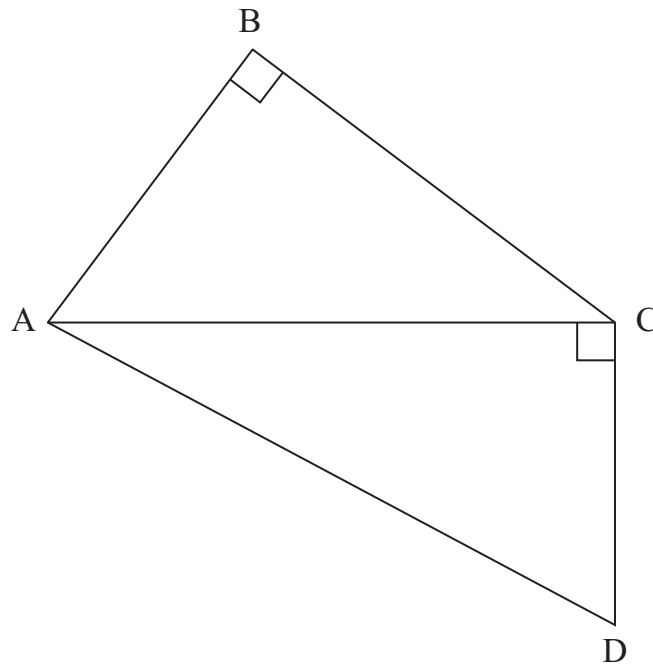

Fig. 2

Forces of 9, 12, 8 and 17N act along the sides AB, BC, CD and DA respectively.

Show that this system reduces to a couple and find its moment.

[7]

- 2 A hovercraft is kept at its equilibrium height above the ground by a flow of gas of density  $d$  and cross-sectional area  $A$  thrusting downwards with velocity  $v$ . Experimental trials have shown that the total weight  $W$ , that the down-thrust can support, is given by

$$W = cAdv^2$$

where  $c$  is a dimensionless constant.

- (i) Show that this formula is dimensionally consistent. [3]

The power developed for vertical thrust by the engine is  $P$ .

- (ii) Show that  $[P] = [M][L]^2[T]^{-3}$  [2]

The power is believed to depend on the properties of the gas jets as follows:

$$P = kA^x d^y v^z$$

where  $k$  is a dimensionless constant.

- (iii) Use the Method of Dimensions to find  $x$ ,  $y$  and  $z$ . [6]

- (iv) Hence confirm that the power to weight ratio of the hovercraft is proportional to  $v$ . [1]

- 3 Three particles, A, B and C with masses  $2m$ ,  $m$  and  $km$  respectively lie in a straight line on a smooth horizontal surface. B and C are at rest and A is moving towards B with speed  $u$ . A collides directly with B. After the collision B moves off with speed  $v_2$  and A follows at speed  $v_1$ . The coefficient of restitution between any pair of particles is 0.5

- (i) Show that  $v_2 = u$  and find  $v_1$  [6]

B then collides directly with C. C moves off with speed  $w_2$  and B follows at speed  $w_1$

- (ii) Find  $w_2$  and show that  $w_1$  is given by

$$w_1 = w_2 - \frac{u}{2} \quad [4]$$

- (iii) Given that there will be at least three collisions, show that  $k > \frac{1}{2}$  [2]

- 4 A particle of mass  $m$  is moving round a vertical circle of radius  $r$  and vertical diameter AOB where O is the centre of the circle and A is above B. When the particle is at P its speed is  $v \text{ ms}^{-1}$  and the angle AOP is  $\theta$  as shown in **Fig. 3** below.

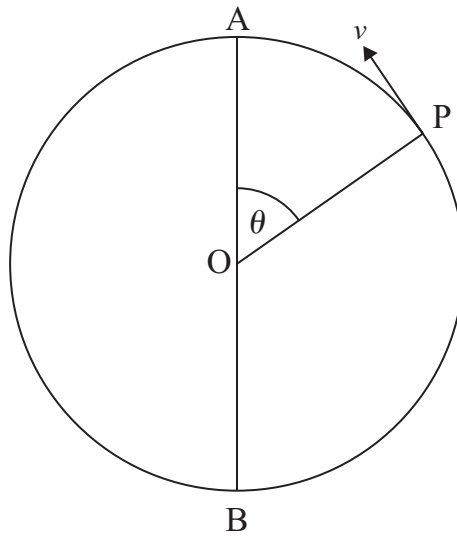

**Fig. 3**

If the gravitational potential energy is zero at B, the kinetic energy of the particle at P is

$$mgr(1 - \cos \theta)$$

- (i) Find the initial speed of the particle if it was projected from B. [2]
- (ii) If the particle is a bead free to move round a vertical circle formed by a smooth fixed rigid wire, find in terms of  $m$ ,  $g$  and  $\theta$ , an expression for the reaction of the wire on the bead at P. [4]
- (iii) If instead, the particle is attached to the end of a light inextensible string and moves in an arc of a vertical circle, find  $\theta$  when the tension in the string vanishes. [2]
- (iv) Show that the particle in (ii) can make complete circles but that the particle in (iii) cannot. [3]

- 5 A car of mass  $m$  kg is travelling at  $v$  ms<sup>-1</sup> in a horizontal circle of radius 50 m round a bend banked at 45° to the horizontal as shown in Fig. 4 below.

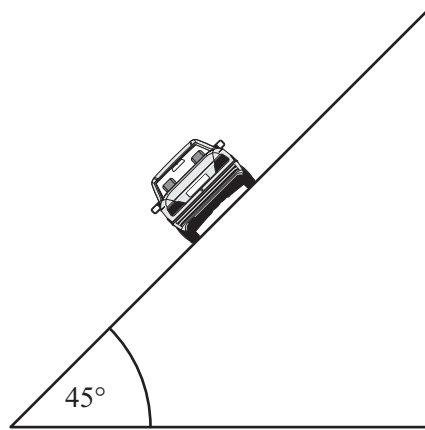

Fig. 4

The coefficient of friction between the car and the road surface is  $\mu$ .

- (i) If the car is just about to slip up the slope, show that

$$v^2 = \frac{490(1 + \mu)}{(1 - \mu)} \quad [8]$$

When the car is travelling more slowly at  $u$  ms<sup>-1</sup> it is just about to slip down the slope.

- (ii) Hence **write down** in terms of  $\mu$  an expression for  $u^2$ , clearly explaining why this can be done. [2]

- (iii) If  $\mu = 0.5$ , show that  $v = 3u$ . [2]

- 6 A paperweight can be modelled by the solid formed when the area bounded by the positive  $x$ -axis, the  $y$ -axis and the curve

$$y = \sqrt{1 - \frac{x^2}{4}}$$

is rotated through  $2\pi$  radians about the  $x$ -axis as shown in **Fig. 5** below.

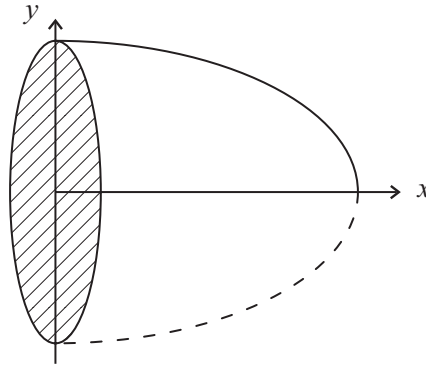

**Fig. 5**

The density of the solid formed is  $\rho$ .

- (i) Show that the moment of this solid about the  $y$ -axis is  $\pi\rho$ . [5]
- (ii) Hence find the distance of the centre of mass of this solid from its plane face. [4]

The paperweight is placed with its plane face in contact with the horizontal surface of a tilting table. When the table is tilted through  $\alpha^\circ$ , the solid is just on the point of toppling but does not slip.

- (iii) Find  $\alpha$ . [5]

---

**THIS IS THE END OF THE QUESTION PAPER**

---

Permission to reproduce all copyright material has been applied for.  
In some cases, efforts to contact copyright holders may have been unsuccessful and CCEA  
will be happy to rectify any omissions of acknowledgement in future if notified.