



ADVANCED SUBSIDIARY (AS)
General Certificate of Education
2009

Centre Number

71	
----	--

Candidate Number

--

Physics

Assessment Unit AS 3B

assessing

Module 3B: Experimental and Investigative Skills

Session No. 1

[ASY32]



WEDNESDAY 13 MAY, MORNING

TIME

1 hour 15 minutes.

INSTRUCTIONS TO CANDIDATES

Write your Centre Number and Candidate Number in the spaces provided at the top of this page.

Turn to page 3 for further Instructions and Information.

For Supervisor's use only

Question 1(a)

Was the previously-connected circuit provided?

YES

NO

For Examiner's use only

Question Number	Marks
1	
2	

Total Marks

--

BLANK PAGE

Instructions to Candidates

Answer **both** the questions in this booklet. Rough work and calculations must also be done in this booklet. Except where instructed, do **not** describe the apparatus or experimental procedures.

The Supervisor will tell you the order in which you are to answer the questions. Not more than 35 minutes are to be spent in answering each question. In Question **1**, you must stop using the apparatus after 33 minutes so that it can be re-arranged for the next candidate. At the end of the 35-minute period you will be instructed to move to the area set aside for the next question. At the end of the Test a 5-minute period will be provided for you to complete the calculations, etc., in either of the questions of the Test, but you will not have access to the apparatus during this time.

Information for Candidates

The total mark for this paper is 45.

Quality of written communication will be assessed in Question **2**.

Question **1** carries 25 marks, and Question **2** carries 20 marks.

Figures in brackets printed down the right-hand side of pages indicate the marks awarded to each part question.

- 1 In this experiment you will use a potential divider circuit to determine the resistance of an unknown resistor.

Aims

The aims of this experiment are

- (a) to connect a potential divider circuit,
- (b) to take a series of readings of input and output voltages,
- (c) to plot and interpret a graph from the experimental results,
- (d) to assess the uncertainty in the experiment.

Apparatus

You are provided with a variable d.c. supply, two digital voltmeters, two resistors labelled R_1 and R_2 and a number of connecting leads. The resistance of resistor R_1 is $820\ \Omega$. The resistance of resistor R_2 is unknown.

Procedure

- (a) Connect the components as shown in the circuit of **Fig. 1.1**.

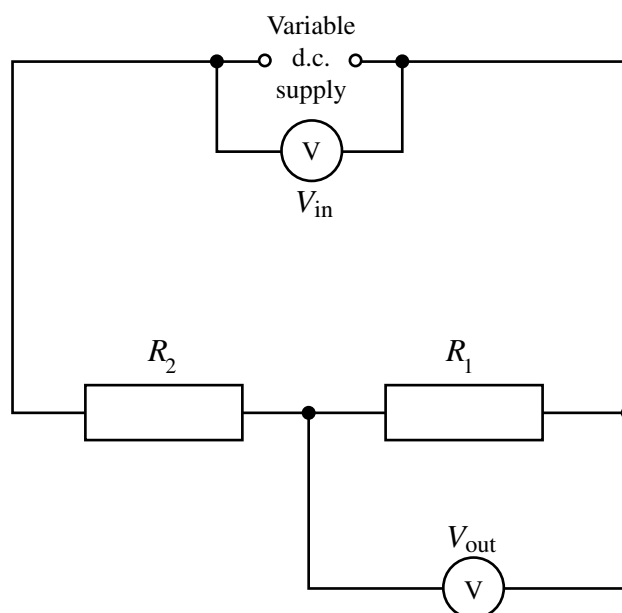

Fig. 1.1

If you are unable to set up this circuit, ask the Supervisor for assistance. A deduction of 3 marks will be made.

[3]

Examiner Only	
Marks	Remark

- (b) You are to obtain a series of readings of output voltage V_{out} for a range of input voltages V_{in} from 0 to 10V. Record your results in **Table 1.1**.

Results

Table 1.1

Input voltage V_{in}/V	
Output voltage V_{out}/V	

[4]

Theory

- (c) The relation between the input voltage V_{in} and the output voltage V_{out} is given by **Equation 1.1**.

$$V_{\text{out}} = \frac{R_1 V_{\text{in}}}{(R_1 + R_2)} \qquad \text{Equation 1.1}$$

where R_1 and R_2 are the resistances of resistors R_1 and R_2 .

Compare **Equation 1.1** with the equation of a straight line

$$y = mx + c$$

- (i) State the quantities which should be plotted to obtain a straight line graph from your results.

x-axis: _____

y-axis: _____ [1]

- (ii) Write down an expression for the gradient of this graph.

gradient: _____ [1]

- (iii) What should be the intercept of this graph?

intercept: _____ [1]

Examiner Only	
Marks	Remark

Graph

- (d) On the grid of **Fig. 1.2**, draw a graph of the quantities identified in (c)(i). Label the axes, choose suitable scales, plot the points and draw the best straight line through them. [5]

Examiner Only	
Marks	Remark

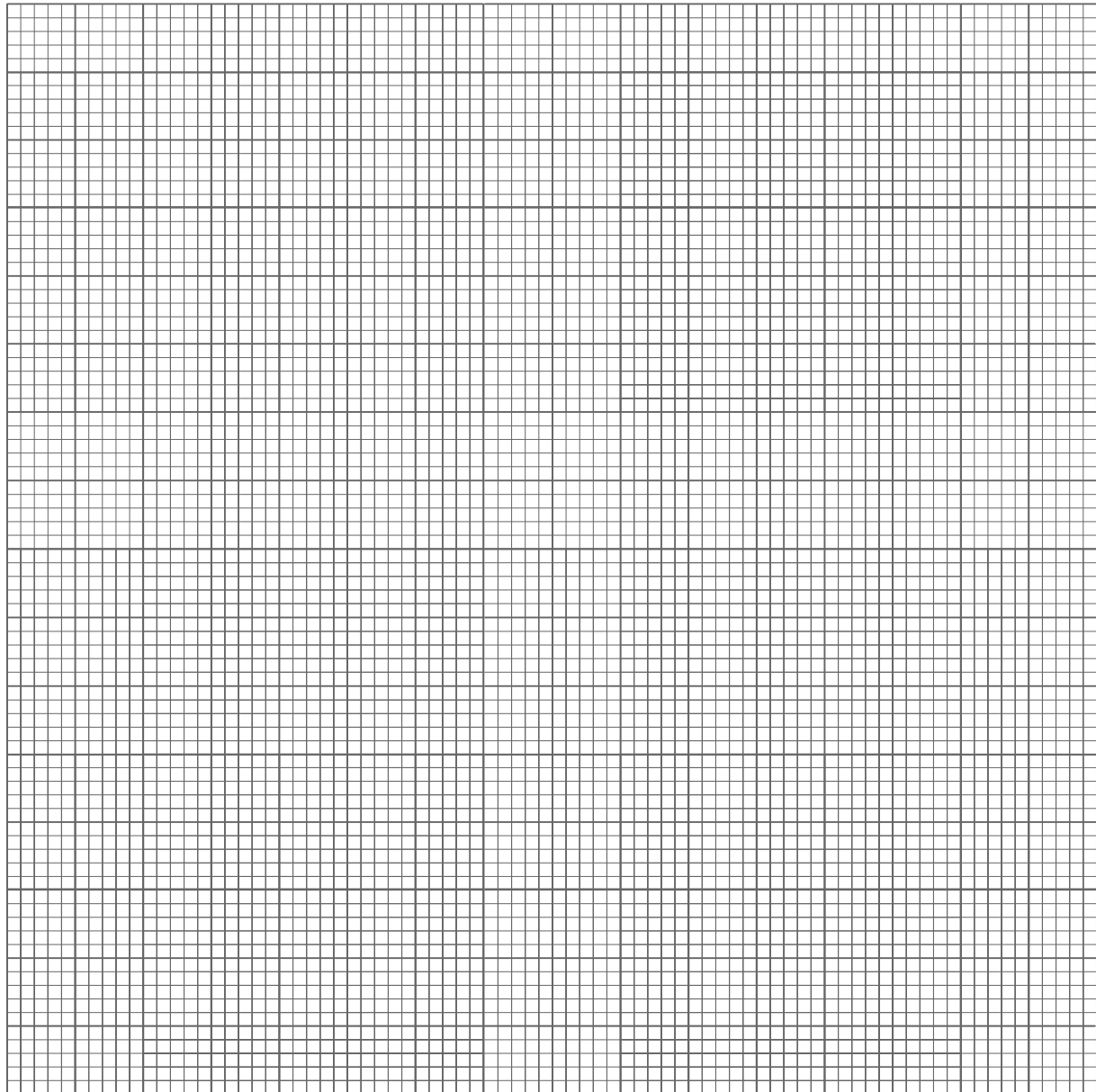

Fig. 1.2

Analysis

- (e) (i) Determine the gradient of your line and state its units. If the gradient does not have a unit, write “NO UNIT”.

Gradient = _____ [3]

Unit = _____ [1]

- (ii) The resistance of resistor R_1 is 820Ω . Use this information and your value of the gradient from (e)(i) to calculate the resistance of resistor R_2 .

Resistance of R_2 = _____ Ω [2]

Examiner Only	
Marks	Remark

Uncertainty

A student performing a similar experiment on a different potential divider measures V_{in} to be $2.44\text{ V} \pm 0.02\text{ V}$ and V_{out} to be $1.56\text{ V} \pm 0.01\text{ V}$.

- (f) (i) Calculate the percentage uncertainty in this student's value for

$$\frac{V_{\text{out}}}{V_{\text{in}}}.$$

Uncertainty in $\frac{V_{\text{out}}}{V_{\text{in}}} = \pm \text{_____} \%$ [3]

- (ii) The student considers repeating the investigation, but this time measuring V_{in} with a voltmeter that is accurate to $\pm 0.01\text{ V}$. The known resistor R_1 in the potential divider is accurate to $\pm 10\%$. Would you advise the student to repeat the investigation with the object of obtaining a more accurate value of R_2 ? Explain your answer.

_____ [1]

Examiner Only	
Marks	Remark

Your answer to part (b)(ii) of this question should be in continuous prose. You will be assessed on the quality of your written communication.

2 Planning and design question

Introduction

In this question you will plan an experiment to investigate how stationary waves may be used to determine the speed of sound in air.

A loudspeaker emits sound waves that travel towards a fixed reflecting surface. The speaker is powered by a signal generator of variable frequency. A microphone detects the displacement of air particles at the position at which it is placed. The displacement is displayed on a cathode ray oscilloscope (c.r.o.). The arrangement is sketched in **Fig. 2.1**.

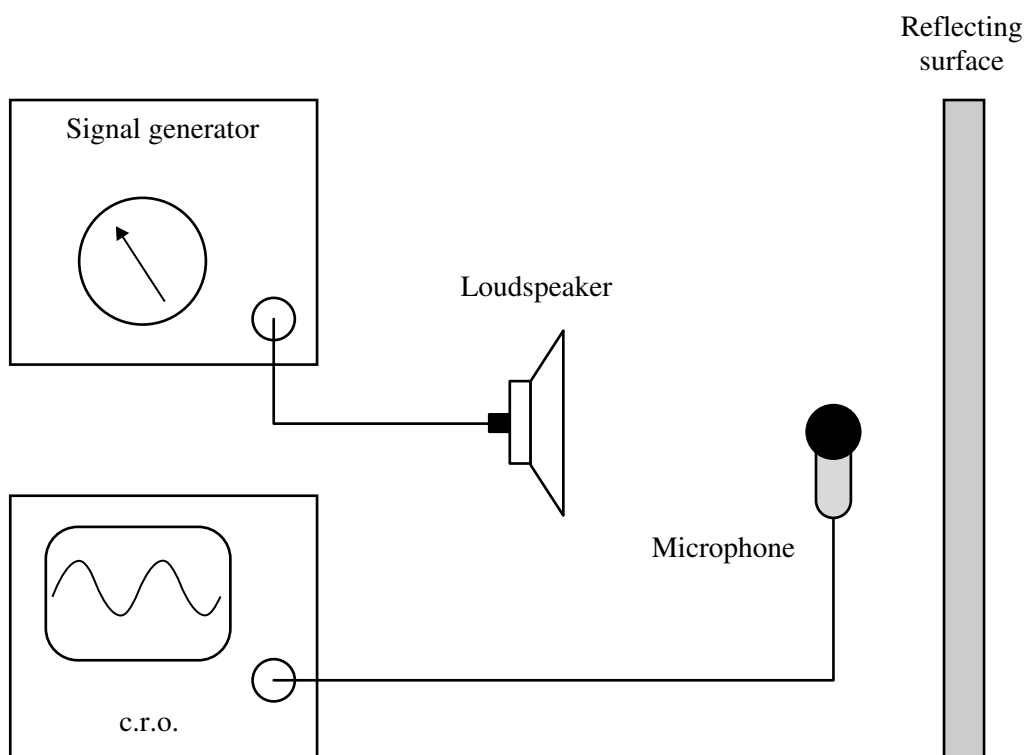
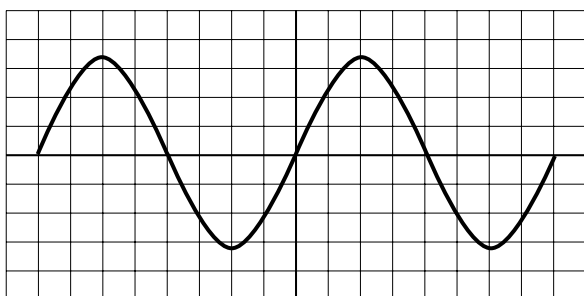

Fig. 2.1

A stationary wave is established between the loudspeaker and the reflecting surface. There will be a series of loud and quiet positions in this region. The amplitude of the c.r.o. trace is proportional to the loudness.

Questions

- (a) Observation of the c.r.o. trace allows the positions of the nodes and the antinodes in the stationary wave to be identified. **Fig. 2.2** shows four possible c.r.o. traces.



A

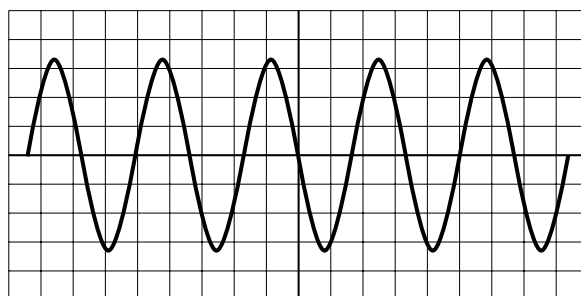

B

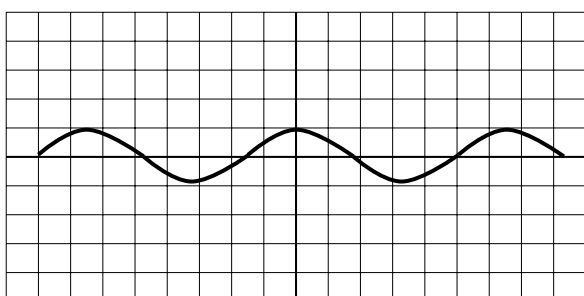

C

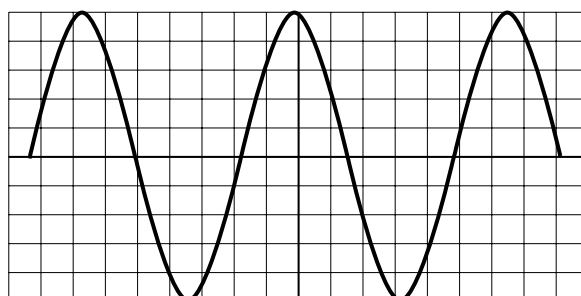

D

Fig. 2.2

Identify the trace most likely to represent the position of a **node**.

Trace _____

Explain why you have selected this trace.

_____ [2]

Examiner Only	
Marks	Remark

- (d) **Fig. 2.4** shows the same graph as in **Fig. 2.3**, but with the addition of an extreme-fit line (the dashed line).

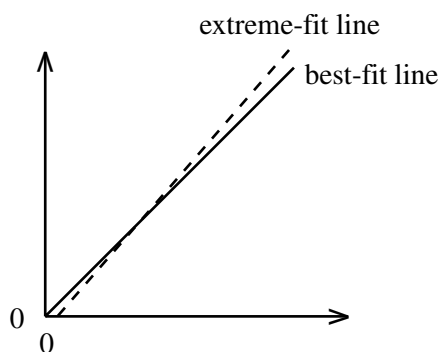

Fig. 2.4

Explain how the extreme-fit line and the best-fit line can be used to obtain the percentage uncertainty in the value for the speed of sound from **(c)(iii)**.

[3]

- (e) Discuss how the uncertainty in the wavelength measurement changes when the frequency of the signal generator is increased.

[2]

THIS IS THE END OF THE QUESTION PAPER

Examiner Only	
Marks	Remark

