

**Published Mark Scheme for
GCE AS Technology and Design**

January 2009

Issued: April 2009

**NORTHERN IRELAND GENERAL CERTIFICATE OF SECONDARY EDUCATION (GCSE)
AND NORTHERN IRELAND GENERAL CERTIFICATE OF EDUCATION (GCE)**

MARK SCHEMES (2009)

Foreword

Introduction

Mark Schemes are published to assist teachers and students in their preparation for examinations. Through the mark schemes teachers and students will be able to see what examiners are looking for in response to questions and exactly where the marks have been awarded. The publishing of the mark schemes may help to show that examiners are not concerned about finding out what a student does not know but rather with rewarding students for what they do know.

The Purpose of Mark Schemes

Examination papers are set and revised by teams of examiners and revisers appointed by the Council. The teams of examiners and revisers include experienced teachers who are familiar with the level and standards expected of 16- and 18-year-old students in schools and colleges. The job of the examiners is to set the questions and the mark schemes; and the job of the revisers is to review the questions and mark schemes commenting on a large range of issues about which they must be satisfied before the question papers and mark schemes are finalised.

The questions and the mark schemes are developed in association with each other so that the issues of differentiation and positive achievement can be addressed right from the start. Mark schemes therefore are regarded as a part of an integral process which begins with the setting of questions and ends with the marking of the examination.

The main purpose of the mark scheme is to provide a uniform basis for the marking process so that all the markers are following exactly the same instructions and making the same judgements in so far as this is possible. Before marking begins a standardising meeting is held where all the markers are briefed using the mark scheme and samples of the students' work in the form of scripts. Consideration is also given at this stage to any comments on the operational papers received from teachers and their organisations. During this meeting, and up to and including the end of the marking, there is provision for amendments to be made to the mark scheme. What is published represents this final form of the mark scheme.

It is important to recognise that in some cases there may well be other correct responses which are equally acceptable to those published: the mark scheme can only cover those responses which emerged in the examination. There may also be instances where certain judgements may have to be left to the experience of the examiner, for example, where there is no absolute correct response – all teachers will be familiar with making such judgements.

The Council hopes that the mark schemes will be viewed and used in a constructive way as a further support to the teaching and learning processes.

CONTENTS

	Page
AS 1: Module 1	1

New
Specification



Rewarding Learning

**ADVANCED SUBSIDIARY (AS)
General Certificate of Education
January 2009**

Technology and Design

Assessment Unit AS 1

assessing

Product Design and Systems and Control

[AV111]

THURSDAY 8 JANUARY, MORNING

MARK SCHEME

In all cases, correct alternative responses will be given full credit.

Section A

- 1 Any type of information on functional requirements from the following:
- Specific mechanical or physical properties
 - Specific characteristics. [1]
- Any type of information on manufacturing demands from the following:
- Scale of production
 - Type of production. [1]
- Any type of information on the environment from the following:
- Outdoor weathering (corrosion)
 - Other external environmental conditions. [1]
- Any type of information on the availability from the following:
- Common forms and sizes
 - Supply time and line. [1]
- 2 Products manufactured from metals use a range of finishes.
- (i) ferrous metals contain iron, non ferrous metals do not. [1]
- (ii) Briefly explain the process of plastic coating and electroplating.
- Plastic coating – metal is heated evenly, plunged into fluidised powder for a few seconds before returning to the oven to completely fuse the plastic to the surface. [2]
- Electroplating – The component to be plated is made the cathode and the coating material the anode. A direct current voltage is applied and metallic ions migrate through the solution to the component. They then lose charge and are deposited as a metal plate. [2]
- 3 Litter bins, storage tanks and traffic bollards are manufactured by the process of rotational moulding.
- (i) Any **one** main reason why rotational moulding is the most suitable from the following:
- Produces a hollow consistent detailed profile
 - Capable of producing large shapes. [1]
- (ii) Any suitable material from the following:
- PVC
 - Nylon. [1]
- (iii) Annotated sketch of a headed mould containing powder. As the plastic melts and the mould rotates, the plastic coats the surface of mould cavity with an even layer of plastic. [3]

4 Manufacturing systems can be organised through cell production, flexible manufacturing systems (FMS), just-in-time (JIT) and concurrent engineering.

For any **three** of the above systems briefly outline **two** main characteristics of each.

Any **two** main characteristics for cell production from the following:

- Production stages are split into individual components
- Each cell has a team of people
- Team is responsible for all aspects of production. [2]

Any **two** main characteristics for flexible manufacturing systems (FMS) from the following:

- Based on flexible workforce and flexible machinery
- People are semi skilled – ability to do a variety of tasks
- Works best with batch production – flexibility essential. [2]

Any **two** main characteristics for just-in-time (JIT) from the following:

- Materials/components bought only when needed
- No stockpile of resources
- Everything kept to time. [2]

Any **two** main characteristics for concurrent engineering from the following:

- Stages of the design process can overlap
- Good communication essential between all stages
- Aim is to design/manufacture with maximum efficiency. [2]

mark for clear and coherent explanation using good English grammar. [1]

5 (i) The main advantage plywood has compared to blockboard is that it is stronger. [1]

(ii) Any **one** main advantage MDF has compared to chipboard from the following:
 ● Stronger material
 ● Better quality finish. [1]

(iii) Any **one** specific application for plywood from the following:
 ● Building and general construction. [1]

Any **one** specific application for MDF from the following:
 ● Furniture. [1]

- 6 For a design and manufacturing company testing, inspecting and quality systems are established procedures.
- (i) Any **two** main reasons why it is so important for a company to test and inspect its products from the following:
- To avoid expensive recalls
 - Ensure consistency/quality of product manufacture
 - To avoid bad publicity
 - To ensure the product or components are capable of doing what they were designed to do. [2]
- (ii) Explanation of QA – is about setting standards and meeting them
At every stage of design and manufacture. [2]
- Explanation of QC – is how you check if you are meeting these standards
This involves inspecting, sampling and testing. [2]
- mark for clear and coherent explanation using good English grammar.** [1]
- 7 Ergonomics are important when designing products such as the mobile phone.
- (i) Ergonomics is about how easy, safe and comfortable a product is to use. [1]
- (ii) Sight – controls screen size and graphics.
Hearing – volume control distance between ear piece and microphone.
Touch – feeling texture of finish. [3]
- 8 (i) Sustainability – ability to maintain our environment over time. [1]
- Life cycle analysis – is the assessment of a product’s waste, emissions and by-products from the initial design brief to disposal. [1]
- (ii) Select a suitable product and briefly explain how the designer has considered sustainability.
- Eg wind up radio/torch – requires no batteries and is supplied with a renewable source of energy. [2]

Section B

9 (a) (i) Nand gate [1]

(ii)

A	B	Q
0	0	0
0	1	1
1	0	1
1	1	1

[3]

(iii) OR gate [1]

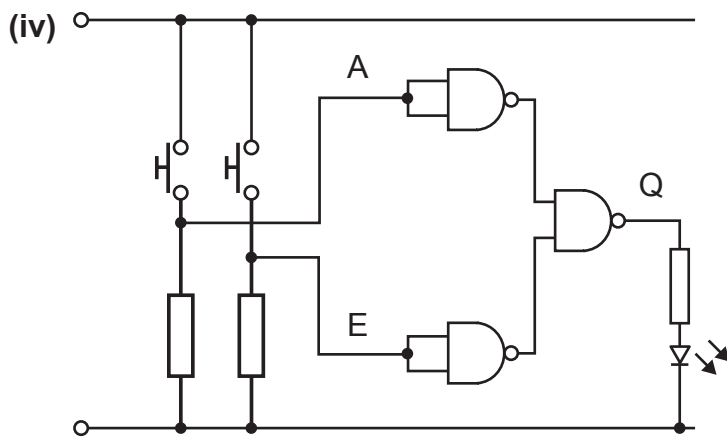

[3]

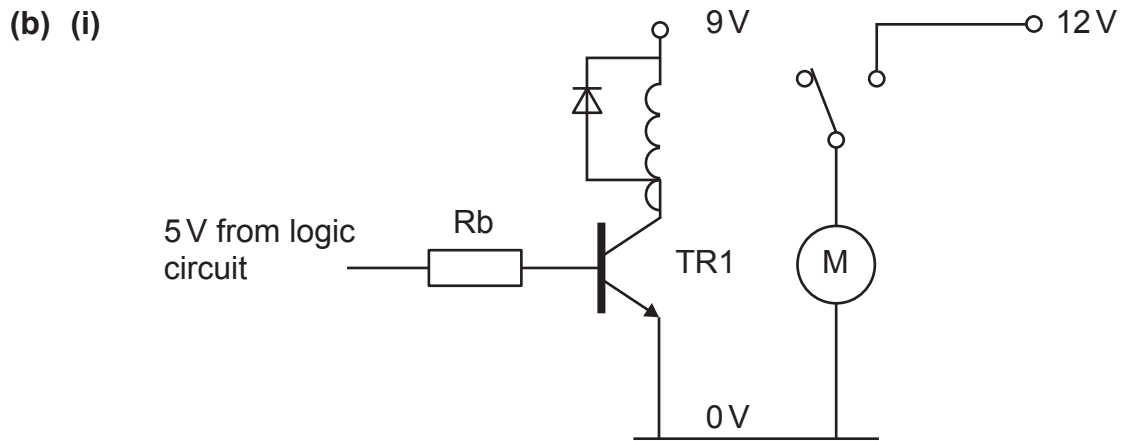

[2]

Fig. 1(b)

(ii) Explanation to include reference to relay and protective diode. [4]

mark for clear and coherent explanation using good English grammar. [1]

(iii) 614 ohms [3]

10 (a) (i) 10 seconds [1]

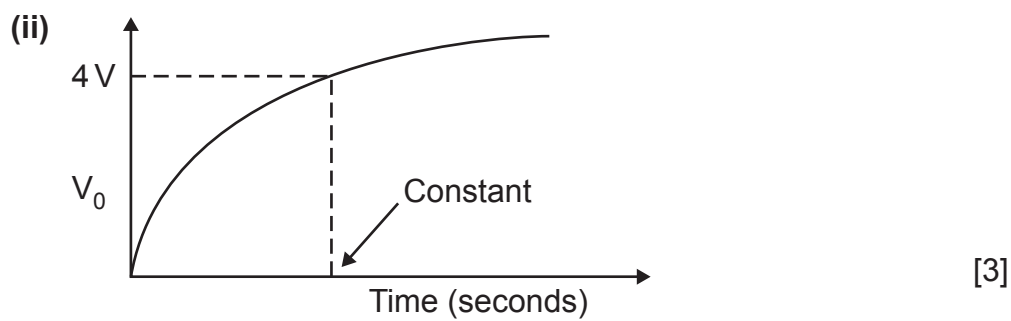

(iii) A low value resistor in series with a PTM switch across the capacitor. [3]

(b) (i) Open loop – there is no feedback from the output. [2]

(ii) Frequency = 45.5 Hz [3]

(iii) Appropriate explanation [5]

mark for clear and coherent explanation using good English grammar. [1]

(iv) Multipole or rotary switch with alternative capacitors [4]

Section C

- 11 (a) (i) Anticlockwise. [1]
- (ii) $A - B = \frac{70}{35} = 2$
 $M - N = \frac{240}{60} = 4$ [1]
 $VR = 2 \times 4 = 8$ [1]
- (iii) $A - C = \frac{70}{35} = 2$
 $D - E = \frac{20}{40} = 0.5$
 Wormwheel = 40 [1]
 $VR = 2 \times 0.5 \times 40 = 40$ [1]
 $\frac{240}{40} = 6 \text{ rev/min}$ [1]
- (iv) $N - M = \frac{60}{240} = \frac{1}{4}$
 $B - C = \frac{70}{70} = 1$ [1]
 $D - E = \frac{20}{40} = \frac{1}{2}$
 Worm = 40 [1]
 $\frac{1}{4} \times 1 \times \frac{1}{2} \times 40 = 5$ [1]
- $Os = \frac{Is}{VR}$
 $2 = \frac{Is}{5} = 10 \text{ rev/min}$ [1]
- (v) Suitable annotated sketch outlining:
 Wheel [1]
 Spring [1]
 Overall combination/method [1]
- mark for clear and coherent explanation using good English grammar.** [1]
- (vi) Suitable annotated sketch outlining:
 Grub screw [1]
 Positioning against shaft [1]
 Positioning on gear [1]

		AVAILABLE MARKS
11	(b) cam and follower or other suitable mechanism.	[1]
	(c) $\text{Eff} = \frac{MA}{VR} \times 100$	
	$\frac{7}{8} = 0.875$	[1]
	$MA = 7$	[2]
12	(a) (i) Push button	[1]
	(ii) Exhaust air	[1]
	(iii) Filter removes moisture and dust from air.	[1]
	Lubrication unit adds small droplets of lubrication to the air.	[1]
	mark for clear and coherent explanation using good English grammar.	[1]
	(iv) Solenoid activation	[1]
	Wiring incorporating switch and power	[2]
	(v) Airbleed at X	[1]
	Correct connection of X	[1]
	Correct connection of Y	[1]
	Correct connection of Z	[1]
	Correct piping	[1]
	(b) Free flow blocked	[1]
	Air forced through flow control valve	[1]
	Starts to fill reservoir	[1]
	Once reservoir filled air passes onwards	[1]
	Or other suitable answer.	
	(c) $F = P \times A$	
	$212 = 0.4 \times ?$	
	$3.14 \times 131 \times 3 = 530$	[2]
	$530 \times 0.4 = 212\text{N}$	
	Piston diameter = 26	[1]
	Section A	40
	Section B	40
	Section C	40
	Total	80

Answer number 12(a)(7(iv) and (v))

