

**GCE A2**

**Technology  
and Design**

**January 2009**

**Mark Scheme**

Issued: April 2009



**NORTHERN IRELAND GENERAL CERTIFICATE OF SECONDARY EDUCATION (GCSE)  
AND NORTHERN IRELAND GENERAL CERTIFICATE OF EDUCATION (GCE)**

**MARK SCHEMES (2009)**

**Foreword**

Introduction

Mark Schemes are published to assist teachers and students in their preparation for examinations. Through the mark schemes teachers and students will be able to see what examiners are looking for in response to questions and exactly where the marks have been awarded. The publishing of the mark schemes may help to show that examiners are not concerned about finding out what a student does not know but rather with rewarding students for what they do know.

The Purpose of Mark Schemes

Examination papers are set and revised by teams of examiners and revisers appointed by the Council. The teams of examiners and revisers include experienced teachers who are familiar with the level and standards expected of 16- and 18-year-old students in schools and colleges. The job of the examiners is to set the questions and the mark schemes; and the job of the revisers is to review the questions and mark schemes commenting on a large range of issues about which they must be satisfied before the question papers and mark schemes are finalised.

The questions and the mark schemes are developed in association with each other so that the issues of differentiation and positive achievement can be addressed right from the start. Mark schemes therefore are regarded as a part of an integral process which begins with the setting of questions and ends with the marking of the examination.

The main purpose of the mark scheme is to provide a uniform basis for the marking process so that all the markers are following exactly the same instructions and making the same judgements in so far as this is possible. Before marking begins a standardising meeting is held where all the markers are briefed using the mark scheme and samples of the students' work in the form of scripts. Consideration is also given at this stage to any comments on the operational papers received from teachers and their organisations. During this meeting, and up to and including the end of the marking, there is provision for amendments to be made to the mark scheme. What is published represents this final form of the mark scheme.

It is important to recognise that in some cases there may well be other correct responses which are equally acceptable to those published: the mark scheme can only cover those responses which emerged in the examination. There may also be instances where certain judgements may have to be left to the experience of the examiner, for example, where there is no absolute correct response – all teachers will be familiar with making such judgements.

The Council hopes that the mark schemes will be viewed and used in a constructive way as a further support to the teaching and learning processes.



## CONTENTS

	<b>Page</b>
A2 3: Unit 6	1





*Rewarding Learning*

**ADVANCED**  
**General Certificate of Education**  
**January 2009**

---

**Technology and Design**

**Assessment Unit A2 3**

*assessing*

**Unit 6 – Systems and Control in Product Design**

**[A2V31]**

**FRIDAY 16 JANUARY, MORNING**

---

**MARK  
SCHEME**

**Section A**

**AVAILABLE  
MARKS**

Answer **either 1(a) or 1(b)**

In all cases suitable alternative responses will be given full credit.

**1 (a) (i)** Suitable composite for the doors – GRP [1]

Any **two** main reasons from the following:

- Improved strength to weight ratio
  - Available in large sizes
  - Tough and good durability
- [2]

**(ii)** Suitable material for the test bed – Cast Iron  
How it would be manufactured – Specific type of casting, e.g. sand [2]

**(iii)** **Two** alternative methods that may be used to detect if the doors have been closed

- Method based on Micro switches
- Method based on Reed switches
- Method based on Infra red

[4]

**(iv)** Logic function used for **two** distinctly different situations on the test rig.  
The test can only begin when the two doors are closed **AND** the operator presses the start button on the control panel

The sequence is stopped by the emergency stop to the left **OR** the emergency stop to the right. [2]

**(v)** Bullet point 1 sample circuit

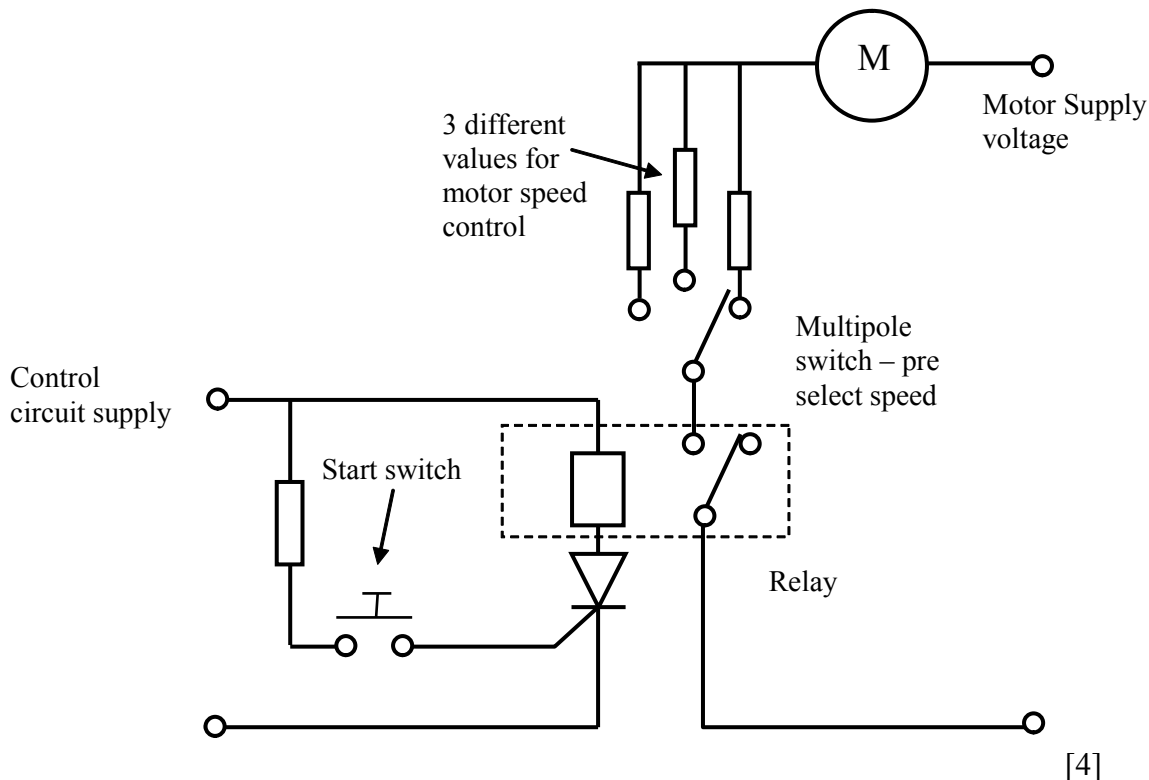



Bullet point 2 sample circuit

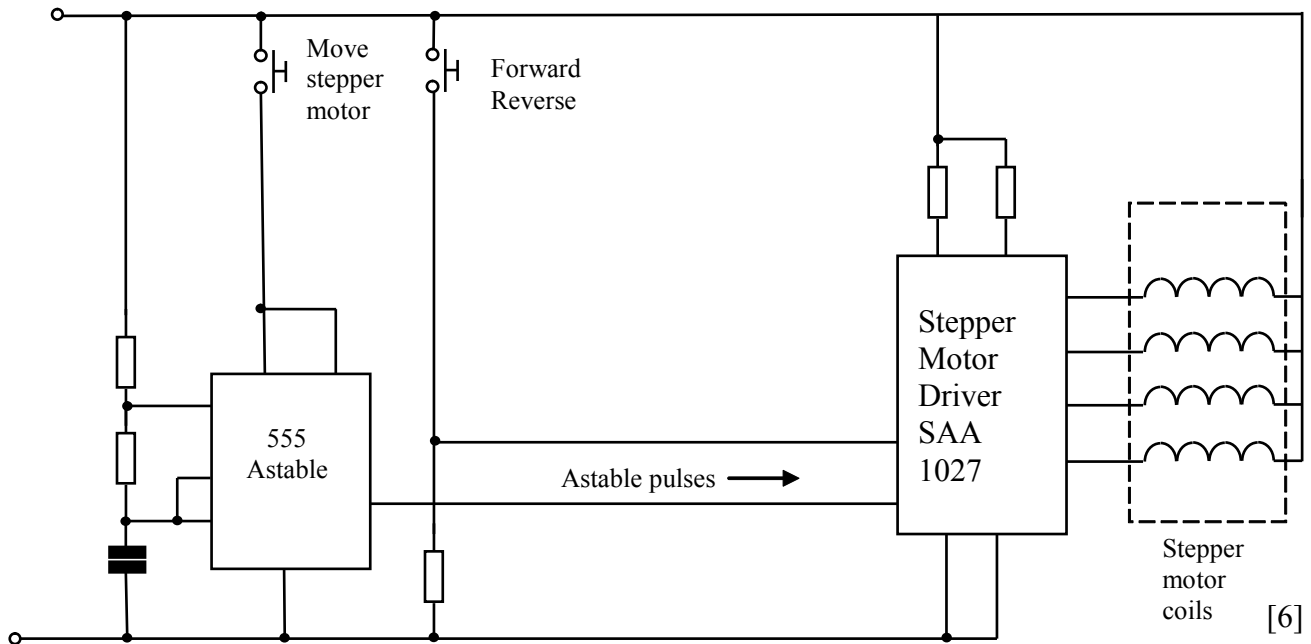

[6]

Bullet point 3 sample circuit

A rotary potentiometer linked to the moving racket holder will provide an analogue signal. Using either an ADC or the ADC port on a PIC, a binary count can be generated. The binary count can be connected to Dual 7 segment displays via a driver/decoders [12]

Bullet point 4 sample circuit

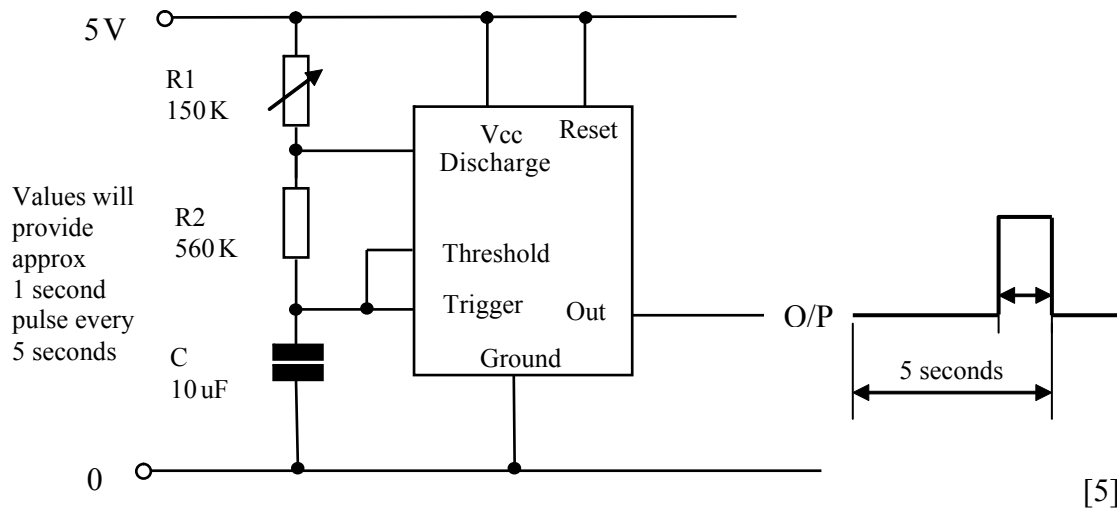

[5]

(b) Pneumatic and Mechanical

(i) Suitable composite for the doors – GRP [1]

Any **two** main reasons from the following:

- Improved strength to weight ratio
- Allows for a good level of transparency
- Tough and good durability

[2]

AVAILABLE MARKS

(ii) Suitable material for the test bed – Cast Iron  
How it would be manufactured – Specific type of casting, e.g. sand [2]

(iii) Two alternative methods that may be used to detect if the doors have been closed  
 • Method based on Micro switches  
 • Method based on Reed switches  
 • Method based on Infra red [4]

(iv) Logic function used for two distinctly different situations on the test rig.  
 The test can only begin when the two doors are closed **AND** the operator presses the start button on the control panel  
 The sequence is stopped by the emergency stop to the left **OR** the emergency stop to the right. [2]

(v) Bullet Point 1  
annotated sketch of a rack and pinion **or** other suitable mechanism [4]  
 Bullet Point 2  
annotated sketch of a motor, shaft and cam system or other suitable mechanism which allow control between position 1 and 2. [6]

Bullet Point 3

20 rpm to 1920 rpm ratio of 1 : 96 This may be achieved by the following:		
2 : 1	20 T	Shaft A
4 : 1	40 T 20 T	Shaft B
4 : 1	80 T 20 T	Shaft C
3 : 1	80 T 20 T	Shaft D
	60 T	Shaft E

[8]

Therefore to achieve 2400 rpm add 100 T to 40 T  
 Therefore to achieve 1200 rpm just add 100 T to 50 T [4]

Bullet Point 4  
annotated sketch of pulleys (key and keyway) attached to shafts with the use of a twisted belt or other suitable mechanism. [5]

**Section A**

**38**

**Section B**

**AVAILABLE MARKS**

2 (a) (i) As light levels increase the resistance of the LDR reduces [1]

(ii) LDR at  $2000 \Omega$   $V_o = 2 \text{ V}$   
 at  $2500 \Omega$   $V_o = 1.71 \text{ V}$  [2]

(b) (i) Gain =  $V_o/V_i$   $100 \text{ mV}/50 \text{ mV} = 2$  [2]

(ii)

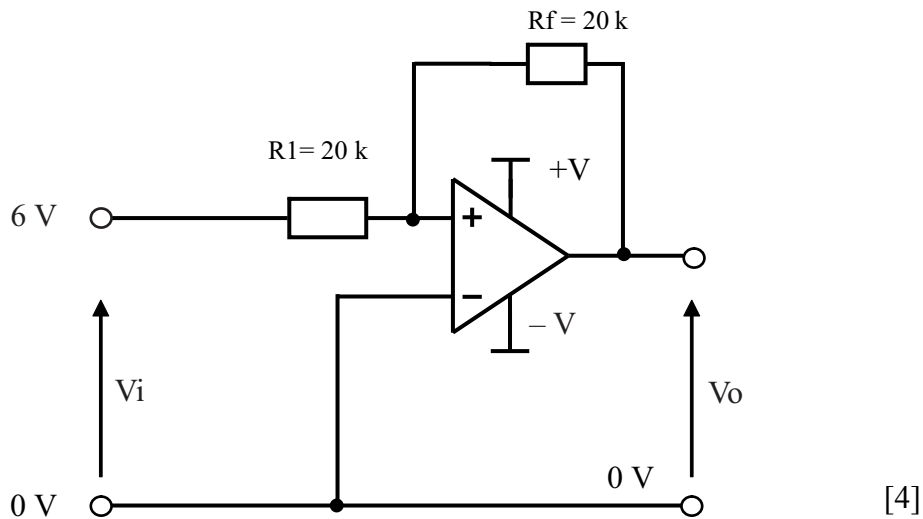

(iii) LED advantage – good in bright ambient conditions, e.g. sunlight  
 disadvantage – higher power consumption  
 LCD advantage – can display wider range of characters  
 disadvantage – more complex driving circuitry [2]

(c) (i) to provide a digital value that represents any given input voltage [2]

(ii) Digital value for 0.8 V  $(0.8 \text{ V}/6 \text{ V}) \times 255 = 34$  [2]

(iii)

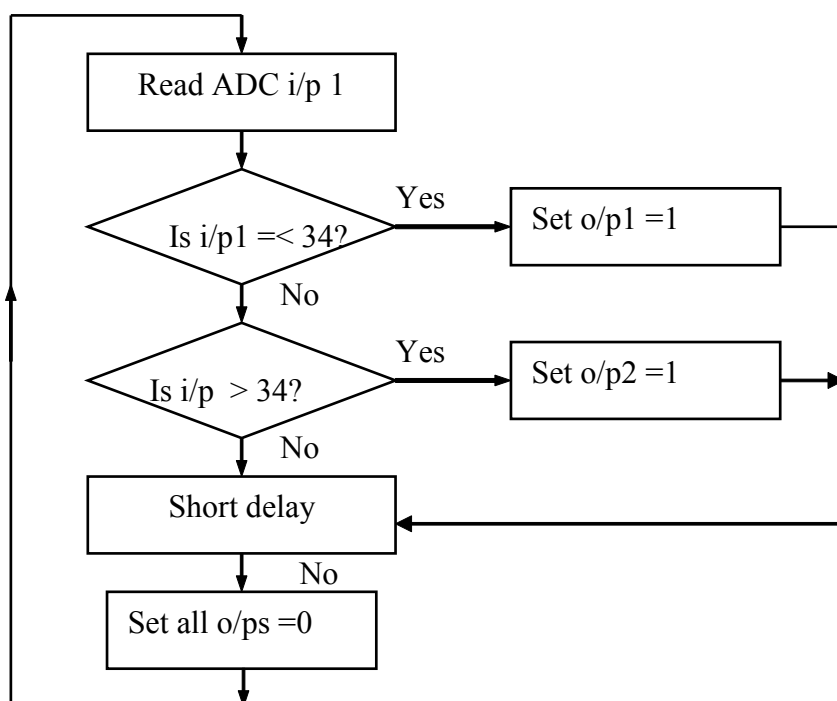

3 (a) (i)

Stage	C	B	A		F
1	0	0	0		1
2	0	0	1		0
3	0	1	0		1
4	0	1	1		0
5	1	0	0		0
6	1	0	1		1
7	1	1	0		0
8	1	1	1		1

[5]

(ii)

AB \ C	00	01	11	10
0	1	1	0	0
1	0	0	1	1

$F = A'C' + AC$  [4]

(iii) Appropriate gate arrangement [2]

(iv) Ultra sonic pulses transmitted. These pulses 'bounce' or reflect when they hit a solid surface. Tuned receiver will detect these pulses. The time lapse between transmission and detection can be used to determine distance or proximity [1]

(b) (i) Transistor – to switch on the high current relay coil from the low current logic circuit  
 Relay – to switch the high voltage water valve using a lower voltage  
 Diode – to protect the transistor from back emf caused by the relay coil [3]

(ii)  $V_{Rb} = 6V - 0.7V = 5.3$  volts  
 $I_c = 6V/60 \text{ Ohms} = 0.1$  amps  
 $I_b = I_c/\text{gain} = 0.001$  amps  
 Therefore  $R_b = 5.3/0.001 = 5300$  ohms [4]

Section B

AVAILABLE MARKS

19

38

**Section C**

**AVAILABLE  
MARKS**

**4 Fig. 4 (a)** shows a cam and follower mechanism used as part of a visual display.

**(a) (i)** Briefly describe **one** advantage and **one** disadvantage associated with the use of a roller follower.

Ans = Advantage – reduced friction/lengthened life span

Disadvantage – may not be able to follow some cam profiles completely

**Or** other suitable answer [2]

**(ii)** The top section of the gearbox housing can be removed to access the gearbox. State a suitable method to prevent oil leakage when the top section is in place.

Ans = Gasket

**Or** other suitable answer [1]

**(iii)** The cam is mounted on a horizontal shaft which runs on plain bearings. During operation the cam has a torque of 1.1 Nm. Showing all calculations state how much work is done against friction after 500 revolutions.

Ans = Work done =  $T\theta$

Angle turned during 500 revs is  $2\pi \times 500 = 3140$  [1]

$1.1 \times 3140 = 3454$  J [2]

**(iv)** Showing all calculations state the power expended in overcoming friction when the cam rotates at 120 rev/min.

Ans =  $P = T\omega$

$120 \times 2\pi/60 = 12.56$  [1]

$12.56 \times 1.1 = 13.8$  W [2]

**(v)** On the pro forma provided (answer number **4(a)(v)**), construct a performance/displacement diagram which would accurately produce the following motion:

• 0–90 rise 40 mm with uniform velocity [1]

• 90–120 dwell [1]

• 120–180 rise 40 mm with uniform velocity [1]

• 180–360 fall 80 mm with uniform acceleration and retardation. [1]

A scale of 1 mm = 1 mm should be used

(see answer)

**(b)** On the pro forma provided (answer number **4(b)**), using appropriate formal drawing techniques, construct a cam profile which would accurately follow the performance/displacement diagram as shown in **Fig. 4(b)**. The diameter of the roller follower is 10 mm and the minimum cam diameter is 30 mm. The roller follower is offset to the right of the cam centre line by 10 mm and the cam rotates in a clockwise rotation.

Ans = 0–180 rise 60 mm with uniform velocity [3]

180–360 fall 60 mm with uniform velocity [3]

(see answer)

19

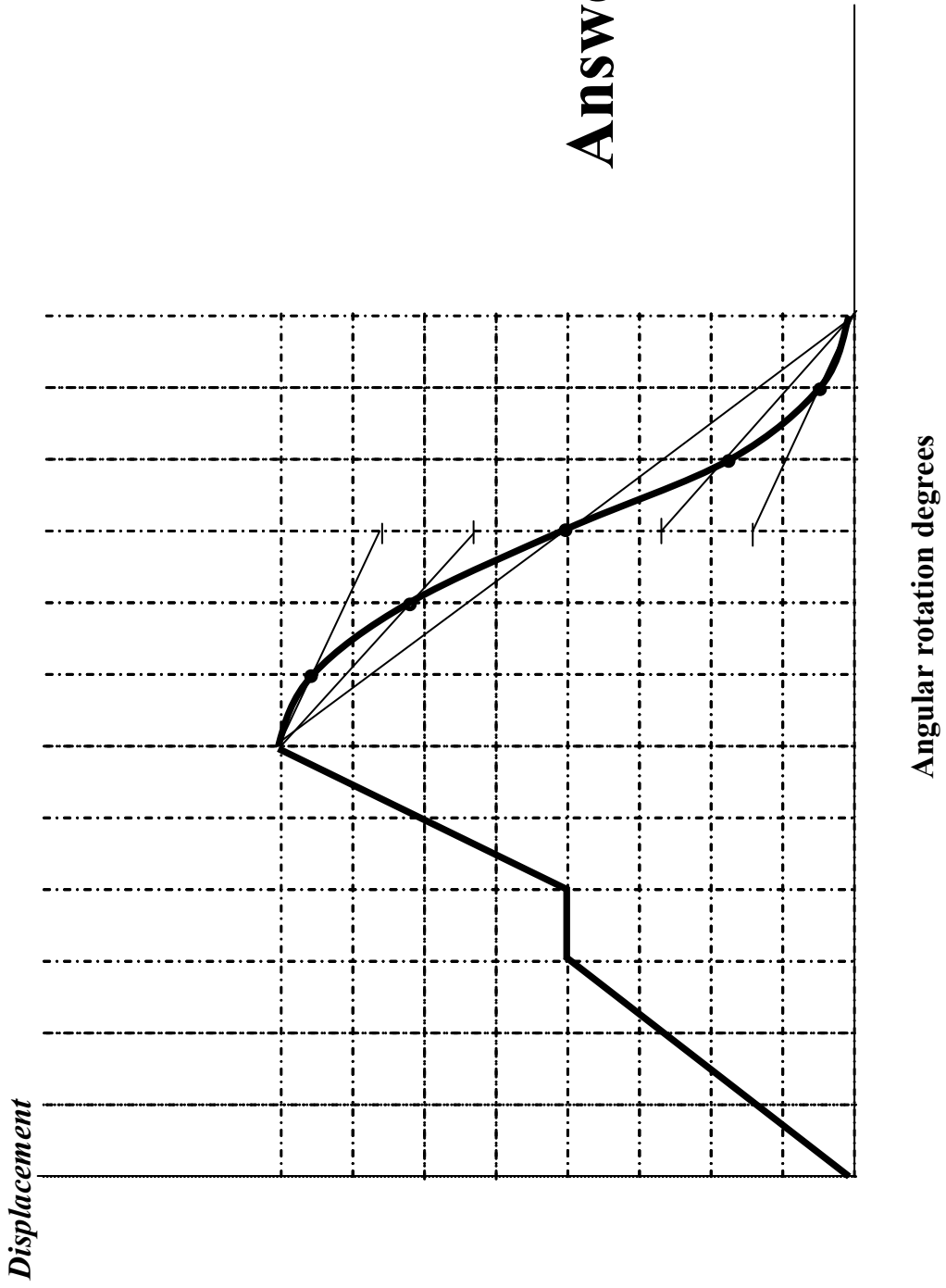

## Answer 4 (a)(v)

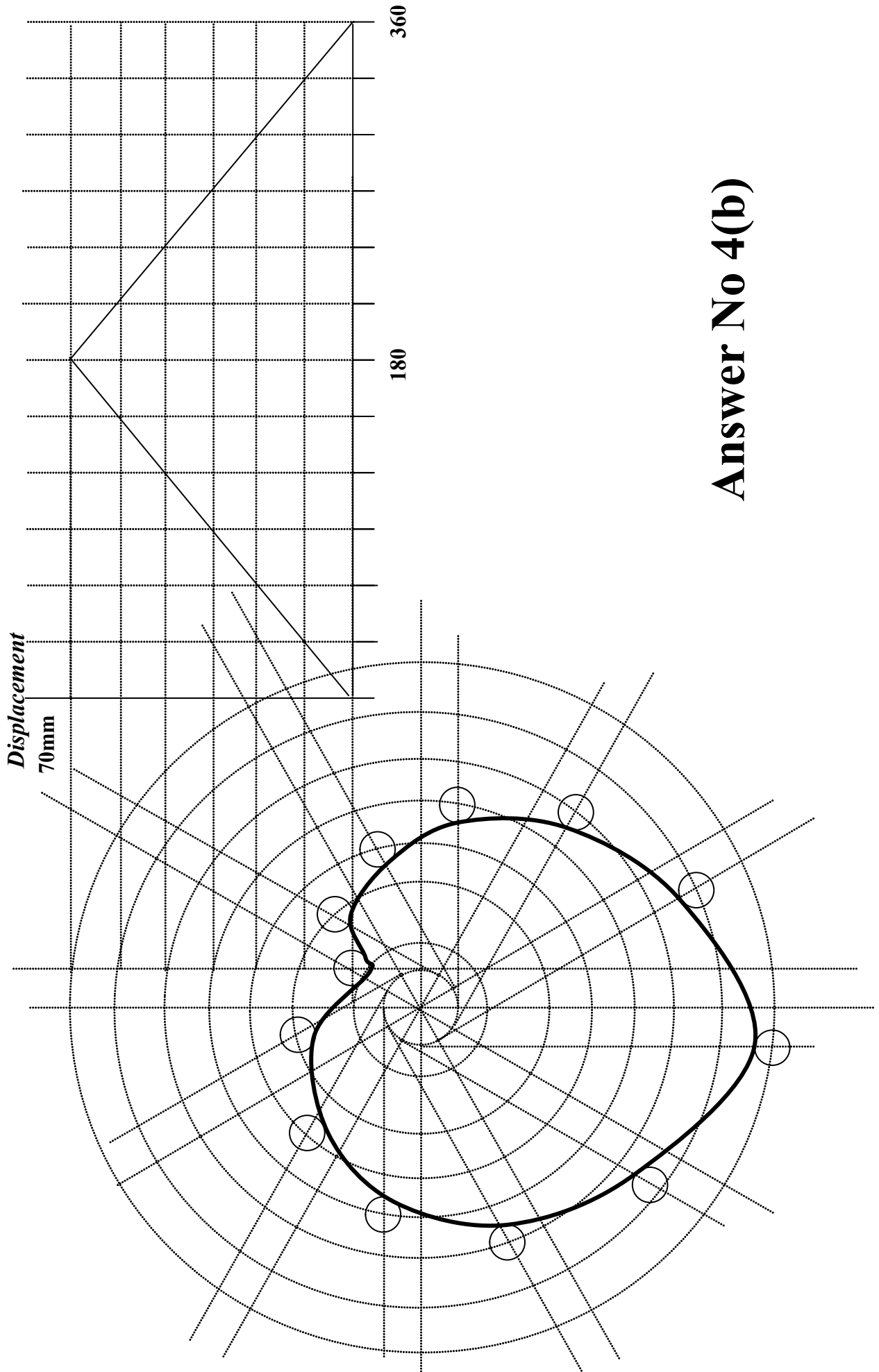

**Answer No 4(b)**

5 Fig. 5 shows parts of a prototype pneumatic recycling station. Used cardboard boxes collected in the hopper are squashed by cylinder D to reduce their storage size.

(a) Briefly state what is meant by the term **positive feedback technique** when applied to pneumatic systems.

Ans = Ensures that each step in the sequence must be followed in order.

**Or** other suitable answer. [1]

(b) (i) The rotary motion is transferred from the motor to the conveyor belt using a cone clutch. Using an annotated sketch outline the main features of a cone clutch.

Ans = Driver cup and cone outlined. [2]

(ii) Briefly describe two methods typically employed to activate clutches.

Ans = Bowden cables, rigid rod/lever and hydraulic systems.

**Or** other suitable answer. [2]

(c) (i) The prototype pneumatic recycling station performs the following sequence once the Start valve is switched:

- Cylinder A outstrokes to secure box 2.
- Cylinder B outstrokes pushing box 1 onto the conveyor belt.
- Cylinder C outstrokes to close the trap door.
- Cylinder D outstrokes to squash box 1.
- Cylinder C instrokes.
- Cylinder D instrokes.
- Cylinder B instrokes.
- Cylinder A instrokes.

[1]

(ii) On the pro forma provided (answer number **5(c)(ii), (iii) and (iv)**) draw a suitable interlocking/cascade sequential circuit to achieve the desired sequence.

Ans = Method of activating cylinder A+ [1]

Method of activating cylinder B+ [1]

Method of activating cylinder C+ [1]

Method of activating cylinder D+ [1]

Method of activating cylinder C- [1]

Method of activating cylinder D- [1]

Method of activating cylinder B- [1]

Method of activating cylinder C- [1]

Group system suitably employed **or** alternative [1]  
(see answer)



**(iii)** During testing it was found that there was insufficient force to adequately squash some of the boxes. On the pro forma provided (answer number **5(c)(ii), (iii)** and **(iv)**) add the necessary components to enable an additional double acting cylinder (Cylinder D1) to operate simultaneously with Cylinder D and easily be switched off if not required

Ans = DAC employed in correct location

Acting simultaneously

Suitable switching off method employed

[2]

**(iv)** Cylinder D a D1 outstroke slowly – see answer page

[2]

**Section C**

**AVAILABLE  
MARKS**

19

**38**

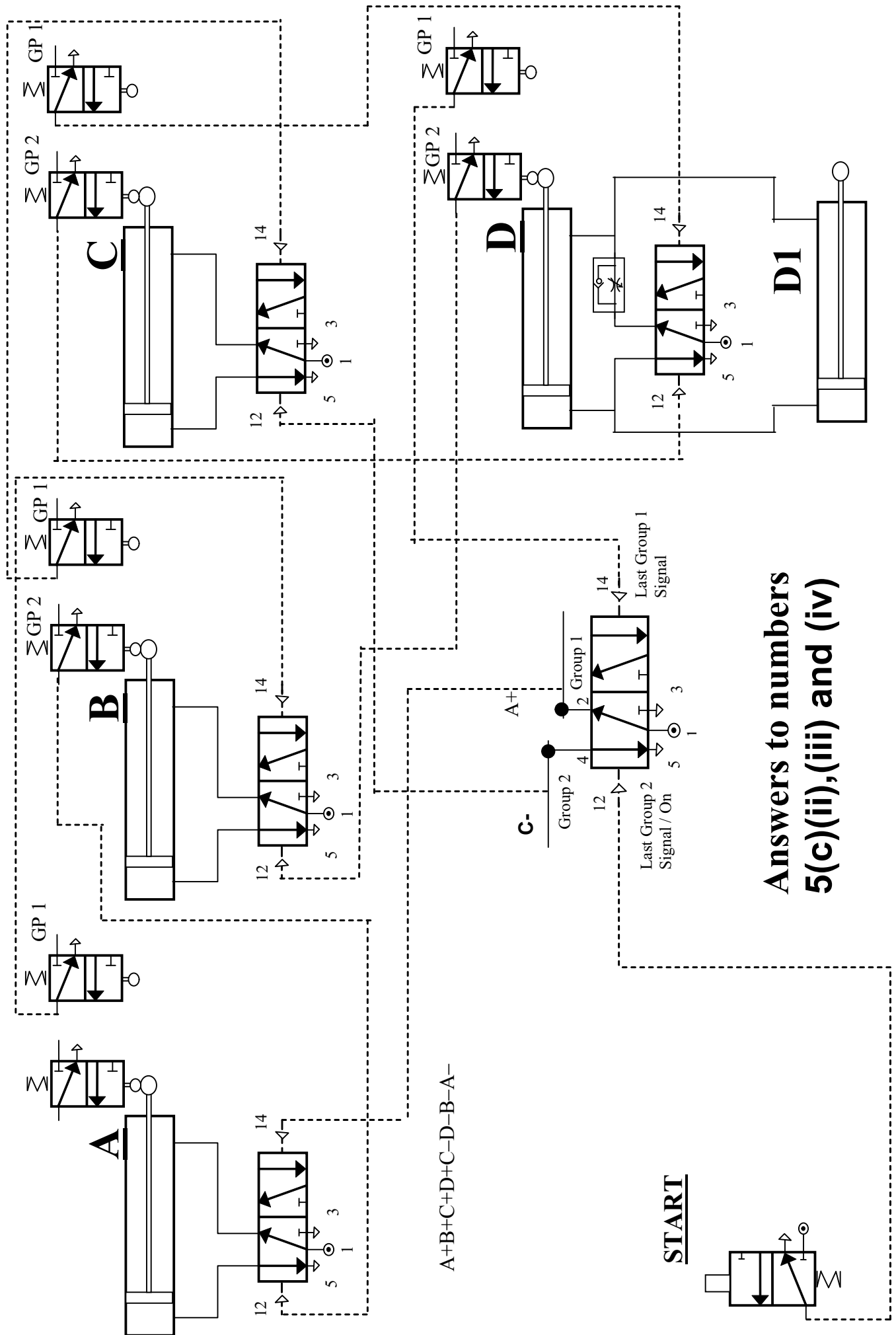

Quality of written communication

Poor selection and use of a writing form and style appropriate to the content. The script content is poorly organised and little use is made of appropriate technological vocabulary. The writing is barely legible and the spelling, grammar and punctuation is inaccurate.	0–2
Good selection and use of a writing form and style appropriate to the content. The script content is organised and use is made of appropriate technological vocabulary. The writing is legible and the spelling, grammar and punctuation is accurate.	3
Very good selection and use of a writing form and style appropriate to the content. The script content is well organised and good use is made of appropriate technological vocabulary. The writing is clearly legible and the spelling, grammar and punctuation is very accurate.	4

[4]

**Total**

**AVAILABLE  
MARKS**

4

**80**

