

General Certificate of Education Advanced Level

www.PapaCambridge.com

Mark Scheme

Important Notice

Mark schemes have been issued on the basis of **one** copy per Assistant Examiner and **two** copies per Team Leader.

- 1 a (i) - OS controls the hardware in such a way that
- the individual does not know that they are using a network
 - OS hides the communication necessary.
- (ii) - Storage space partitioned into many logical areas
- Storage is allocated to users of the network by system manager
 - OS allows normal file manipulation of a stand alone
 - Some file areas may be shared
- (iii) - Different user types given different rights
- R/O, other protections on files/data
 - Passwords and ID to establish identity
- (1 per -, max 2 per dotted, max 6) [6]
- b
- HCI
 - Type/to allow communication
 - Utility programs
 - Routines that the OS makes available to the user/example
 - Hardware control/Input and Output
 - Software routines to control the hardware/device drivers
 - Multi tasking capability
 - allows different Windows/user can carry on more than one task at a time
 - Spooling
 - to queue jobs for input/printing/..
 - Security
 - to ensure that different users can keep files confidential
- (1 per -, max 2 pairs, max 4) [4]
- 2
- Much of the work will involve text files produced by the students
 - speed of processors not important
 - Storage of work may be:
 - central on a shared large volume hard drive
 - or on individual memory sticks requiring USB ports (accept floppy drives)
 - Video of drama productions of literary works
 - requiring high speed processors
 - star/high speed network requirements (optic fibre) *- requires large volume storage.*
 - Printers need only be monochrome because of type of work to be output
 - Unless media studies is mentioned needing high quality colour printing
 - Credit for extra storage device, with reason
 - CDRW to back up students' work from hard drive.
 - Credit for mention of need for system to be compatible with others in school.
- (1 per -, max 7) [7]

- 3 a - Array may become full because of a lot of print jobs being sent together/end of lesson
 - Linked list does not needlessly take up space in memory
 - Print jobs may be inserted into queue if they have a high priority.
 (1 per -, max 2) [2]
- b In any form (can alter depending on which end of list is front of queue)
 - Find print Q in head of list table
 (i) - Insert data into free space
 - H of L points to new node
 - new node points to old first value
 - mention of insertion of high priority jobs into queue
 (ii) - follow pointers to null pointer
 - read address of print job
 - move null pointer to previous node
 - return node to free space
 (1 per -, max 3 per dotted, max 5) [5]
- 4 Data:
 - Personal contact details
 - Financial details/credit card numbers/account numbers
 Problems:
 - Details of cards not typed in/communicated accurately
 - Hackers attacking communications
 - Hackers attacking customer/order database
 - Workers misusing data
 - Data being distributed, leading to unsolicited communications
 - Some potential customers could be put off by worries about use of data
 Solutions:
 - Validation of data input e.g. check digit
 - Verification of communication e.g. Parity
 - Encoding data
 - Digital signatures
 - Passwords to enter database
 - Workers subject to data protection legislation/confidentiality contracts.
 - Company publishes code of conduct to increase confidence of users.
 - Workers not allowed portable storage devices.
 (1 per -, max 8) [8]
- 5 a e.g. Automatic stock control system (accept any sensible application where data is valuable) [1]
- b - Accuracy
 - Less chance of error/less chance of missing something
 - Up to date
 - can be kept permanently up to date
 - VANS
 - arranges for transfer of data from one place to where it is needed
 - Data mining
 - the ability to trawl large quantities of data to find relevant information
 (1 per -, max 3 pairs, max 6) [6]

- 6 a (i) - The value to be searched for is passed/in this case the actual name "SMITH" passed
(ii) - The address of the value is passed/The location of the name is passed (allowing it to be altered if necessary). [2]
- b (i) - The value of the variable only exists in the procedure
- The counter used to control the loop (so that it does not effect a repeat use of the variable).
(ii) - the value of the variable exists throughout the code of the program
- the variable used to hold the details searched for (needs to be used outside the procedure).
(Note: Other examples are fine with reasonable explanation. 1 per -, max 4) [4]
- c - Interpreter translates one command at a time and runs it before the next is translated.
- Used during writing because it aids debugging
- (Compiler translates whole program) into object code (before running)
- Runs faster once it has been called/may be held as a library routine.
-(1 per -, max 4) [4]
- d - Decides where to place programs and procedures
- Loads program and procedures into memory
- Adjusts memory addresses to match locations used
(1 per -, max 2) [2]
- 7 a - Instructions and data stored together in same memory
- Single processor used
- Uses serial processing of instructions
- (1 per -, max 2) [2]
- b (i) - many processors are used...
- simultaneously
- all doing some processing required by the application
- Special non-linear programs must be produced
(1 per -, max 2) [2]
- (ii) - A suitable example e.g. .Weather forecasting.
- Large amount of processing required
- the results from which are time sensitive
(1 for application, 1 for reason) [2]
- 8 a - Production of a test prototype would be very expensive
- Time taken to produce and test a prototype may be too long/immediate need
- Need to test in circumstances unable to be reproduced
- May be too dangerous to test in reality
- Situations can be reproduced which may never arise in ordinary testing
(1 per -, max 3) [3]
- b - No positive reasons of time/danger
- Impossible to simulate a physical action like cutting grass
- Lawn mower can be produced easily
- large quantity will be sold so prototype costs easily covered
(1 per -, max 2) [2]

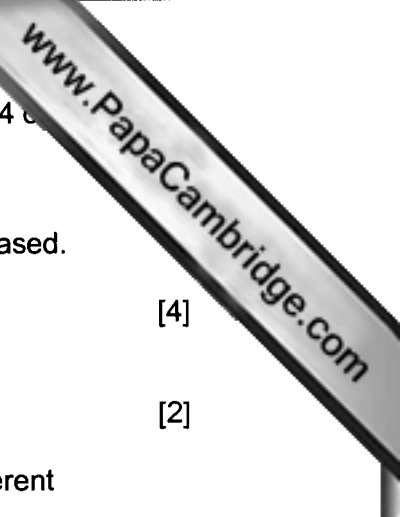

- 9 a
- Range is decreased...
 - because power of two which the mantissa is multiplying by is decreased.
 - Accuracy is increased...
 - because more digits are represented after the binary point. [4]
- b
- $\frac{1}{2} \times 2^0$ (2 marks or 1 for each part)
 - $\frac{1}{2}$ or .5 (2 marks) [2]
- c
- A normalised value must have the first two bits of the mantissa different
 - Therefore one must be a 1
 - which must represent either -1 or $+\frac{1}{2}$, but not zero. [2]
 - (1 per -, max 2)

10

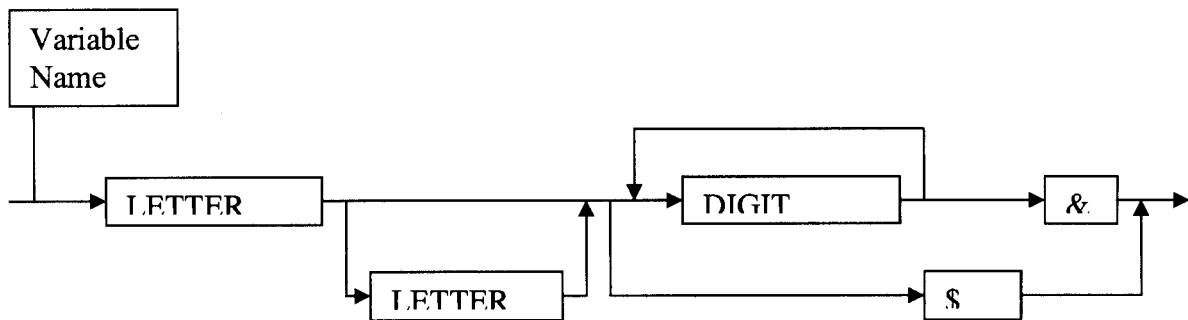

Mark Points:

- Recognisable syntax diagram showing sequence
- Single letter possible
- Two letters, without more, possible
- Single digit possible
- Loop for multiple digits...
- **inside** \$ loop
- Dollar loop correctly positioned to miss Digits and &
- & after digits loop
- (1 per -, max 6)

[6]

- 11 a External level gives the different views of the data seen by each of the users.
Conceptual level is an integration of all the user views of the data/abstract representation of the whole database.
Internal level is the structure used for storage of the data/the logical arrangements of the data for storage. [3]
- b (i) - Used to define the data tables
- Specifies data types and structures
- Specifies constraints on the data
- (ii) - Allows the user to
- Insert
- Update
- Delete
- Modify
- Retrieve
data
(1 per -, max 2 per doty, max 4) [4]
- 12 - All staff will need training relevant to their work
- Many staff will find the new systems difficult to learn
- Type of training important:
- Course type with trainer
- restricts learning times/can be intimidating/difficult to satisfy all demands
- Electronic/Software based
- Training on system at time user is free/individual training takes away intimidation/allows for practice/repetition
- Age problem of trainees/young have preconceptions, old have worries of ability
- Customers have problem with new systems/must learn new procedures
- Change of enquiries/ordering procedures to on-line
- Necessary regular upgrades of software and hardware cause repeats of problems as training needs to be repeated.
(1 per -, max 7) [7]