



# Cambridge International AS & A Level

**DESIGN & TECHNOLOGY**

**9705/12**

Paper 1

**May/June 2024**

**3 hours**



You must answer on the answer booklet/paper.

You will need: Answer booklet/A4 paper                      Coloured pencils  
A3 drawing paper (2 sheets)                      Extra sheets of A3 drawing paper if needed  
A range of design drawing equipment

## INSTRUCTIONS

- Answer **three** questions in total:
  - Section A: answer **one** question on the answer booklet/A4 paper provided.
  - Section B: answer **one** question on the answer booklet/A4 paper provided.
  - Section C: answer **one** question on A3 drawing paper. Use both sides of the paper.
- You may request additional sheets of A3 drawing paper, but only if you have used up both sides of each of the 2 sheets provided.
- If you have been given an answer booklet, follow the instructions on the front cover of the answer booklet.
- Use a black or dark blue pen.
- Write your name, centre number and candidate number on all the work you hand in.
- Do **not** use an erasable pen or correction fluid.
- You may use an HB pencil, or coloured pencils as appropriate, for any diagrams, graphs or rough working.
- At the end of the examination, fasten all your work together. Do **not** use staples, paper clips or glue.

## INFORMATION

- The total mark for this paper is 120.
- The number of marks for each question or part question is shown in brackets [ ].
- All dimensions are in millimetres.

This document has **12** pages. Any blank pages are indicated.

## Section A

Answer **one** question from this section on the Answer Booklet/A4 paper provided.

- 1 Fig. 1.1 gives details of a balancing figure which is to be made in a school workshop.

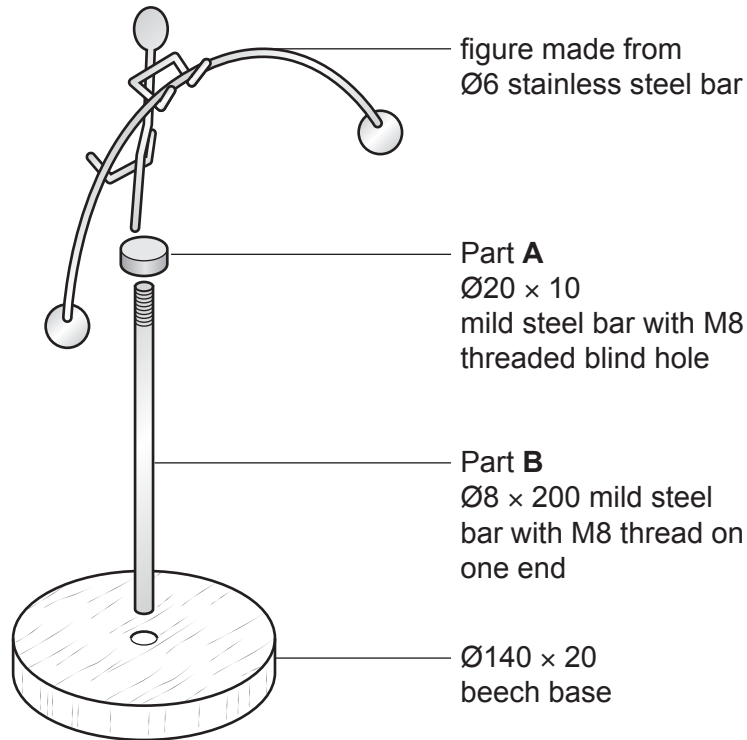

Fig. 1.1

- (a) Give **two** reasons why stainless steel bar has been used for the figure. [2]
- (b) Use notes and sketches to describe:
- (i) how to cut the thread in Part A [6]
  - (ii) how to prepare the surfaces and apply a finish to the mild steel parts. [6]

You must give details about the tools, equipment and processes involved and the safety precautions that have to be undertaken at each stage.

- (c) Use notes and sketches to describe a method of making the beech base. [6]

You must give details about the tools, equipment and processes involved and the safety precautions that have to be undertaken at each stage.

2 Fig. 2.1 gives details of an architectural model which is to be made in a school workshop.

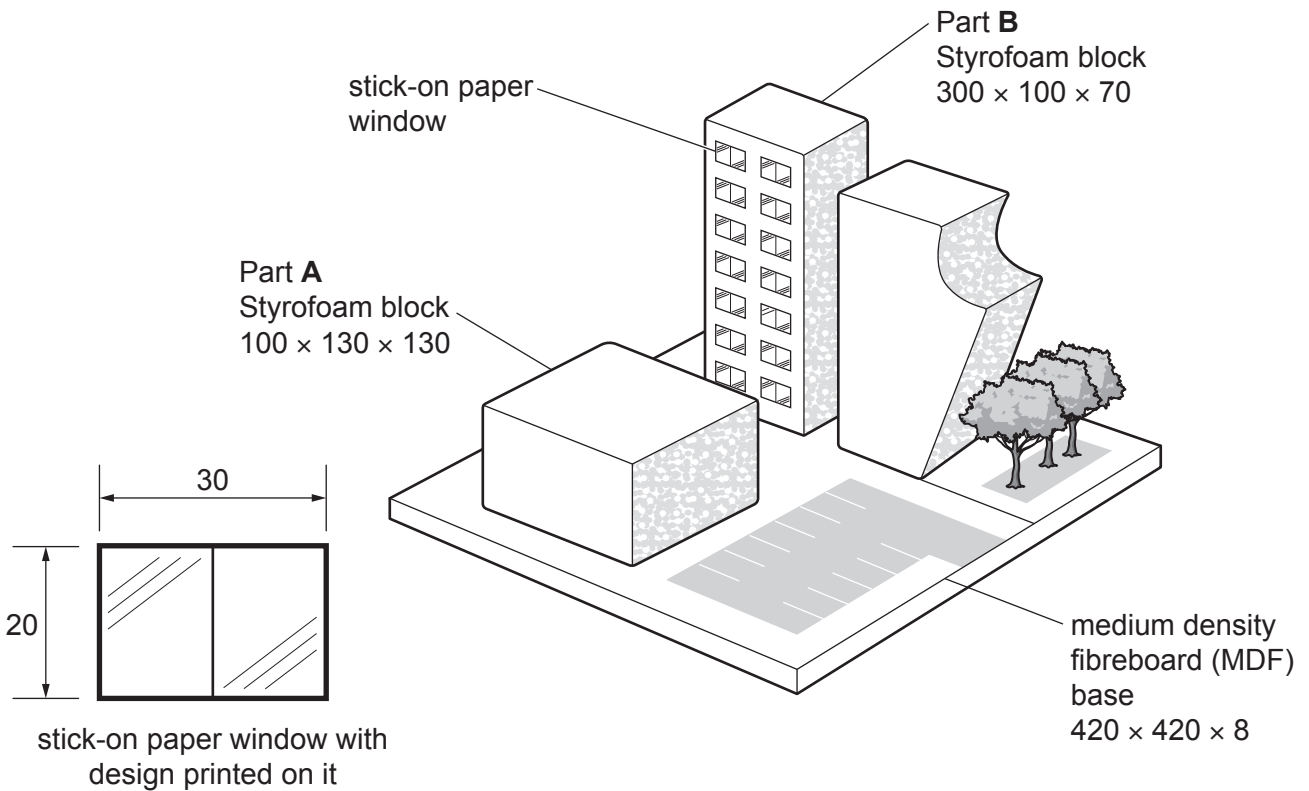

Fig. 2.1

(a) Give **two** reasons why medium density fibreboard (MDF) has been used for the base of the architectural model. [2]

(b) Use notes and sketches to describe how to make Part **A** from a sheet of 20mm thick Styrofoam. [6]

You must give details about the tools, equipment and processes involved and the safety precautions that have to be undertaken at each stage.

(c) Use notes and sketches to describe:

(i) how to make fourteen identical stick-on paper windows with the design printed on them [6]

(ii) how to attach the fourteen windows so that they are evenly spaced on the  $300 \times 100$  side of Part **B**. [6]

You must give details about the tools, equipment and processes involved and the safety precautions that have to be undertaken at each stage.

3 Fig. 3.1 gives details of a model of a wind turbine which is to be made in a school workshop.

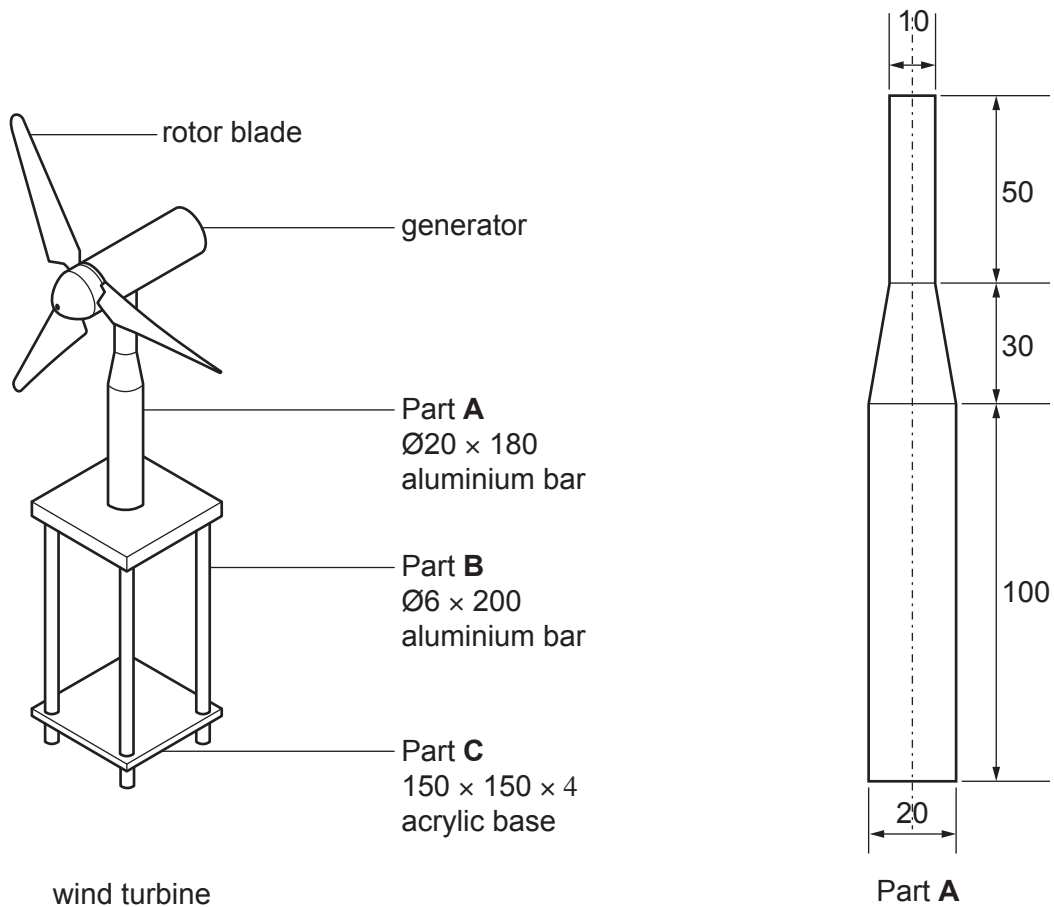

**Fig. 3.1**

(a) Give **two** reasons why aluminium has been used for parts of the model of the wind turbine. [2]

(b) Use notes and sketches to describe:

(i) a method of making Part A [6]

(ii) a method of temporarily joining Part B to Part C. [6]

You must give details about the tools, equipment and processes involved and the safety precautions that have to be undertaken at each stage.

(c) Use notes and sketches to describe how the model of the wind turbine would generate an electric current. [6]

## Section B

Answer **one** question from this section on the Answer Booklet/A4 paper provided.

4 Fig. 4.1 shows details of an incomplete design for a sail to provide shade in a school playground.

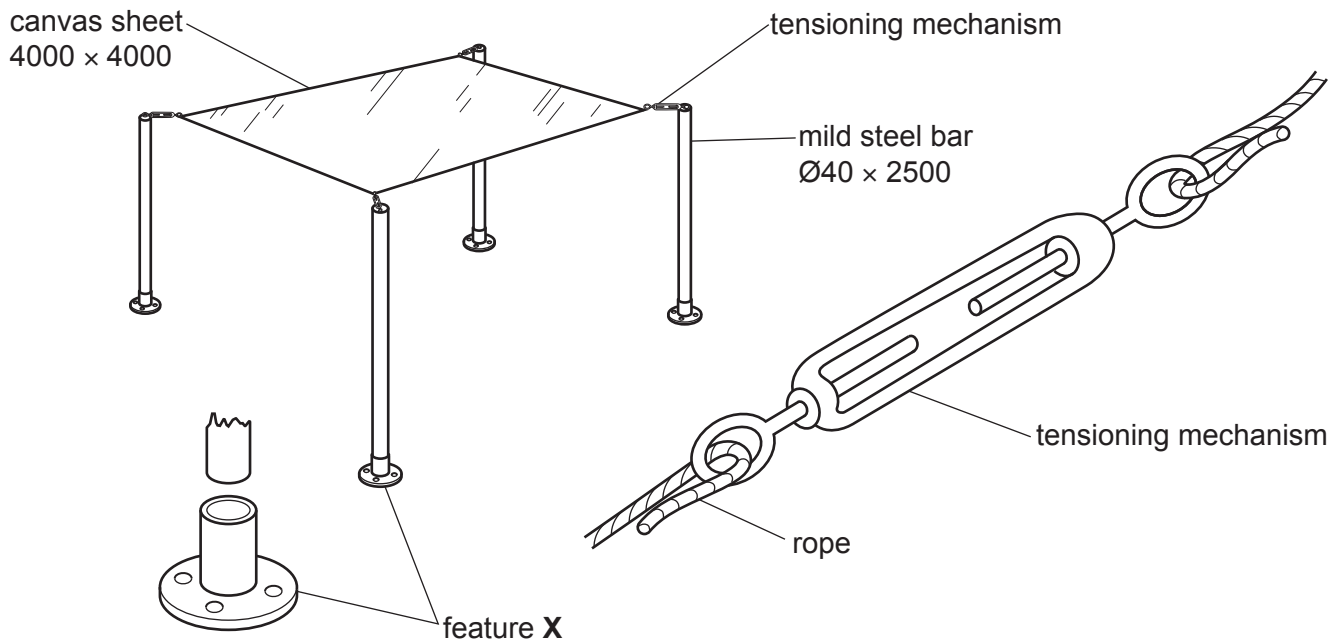
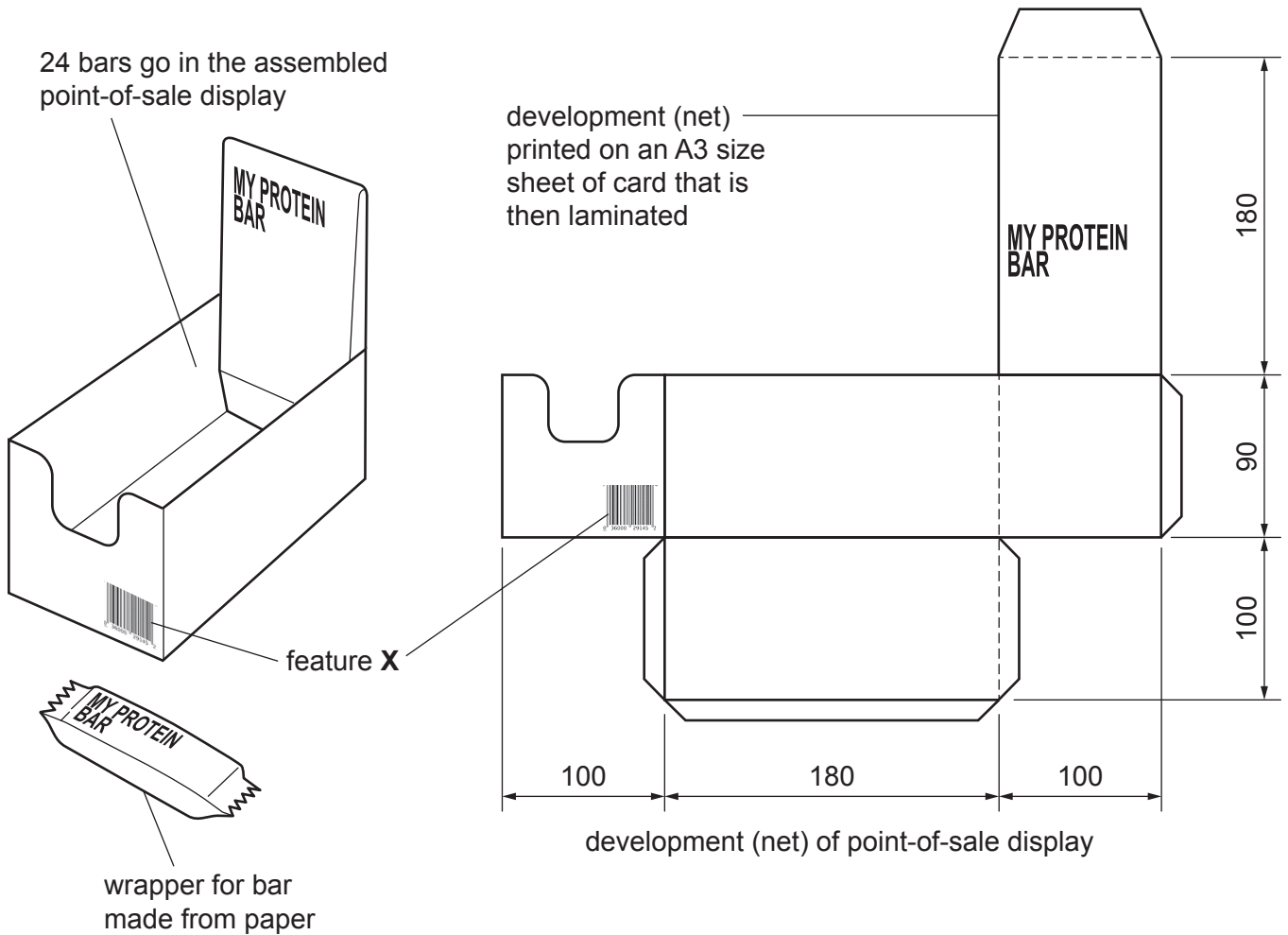

Fig. 4.1

- (a) Explain the function of the design feature shown at X. [2]
- (b) Identify and describe **two** problems with the sail. [4]
- (c) Use notes and sketches to explain how the design of the sail would need to be changed to overcome the **two** problems you have identified in **part (b)**. [6]
- (d) Discuss why some products are designed to be assembled by the customer.  
Your answer should:
- (i) analyse the given situation and identify **three** relevant issues raised by the question [3]
  - (ii) explain why you consider these issues to be relevant [3]
  - (iii) contain specific examples/evidence to support your conclusions. [2]

5 Fig. 5.1 shows an incomplete design for a point-of-sale display for protein bars.



**Fig. 5.1**

- (a) Explain the function of design feature X. [2]
- (b) Identify and describe **two** problems with the point-of-sale display. [4]
- (c) Use notes and sketches to explain how the point-of-sale display would need to be changed to overcome the **two** problems you have identified in **part (b)**. [6]
- (d) Discuss why packaging can be produced in one factory and the product inserted into the packaging in another factory. Your answer should:
- (i) analyse the given situation and identify **three** relevant issues raised by the question [3]
  - (ii) explain why you consider these issues to be relevant [3]
  - (iii) contain specific examples/evidence to support your conclusions. [2]

6 Fig. 6.1 shows details of an incomplete design for a hydraulic lifting device.

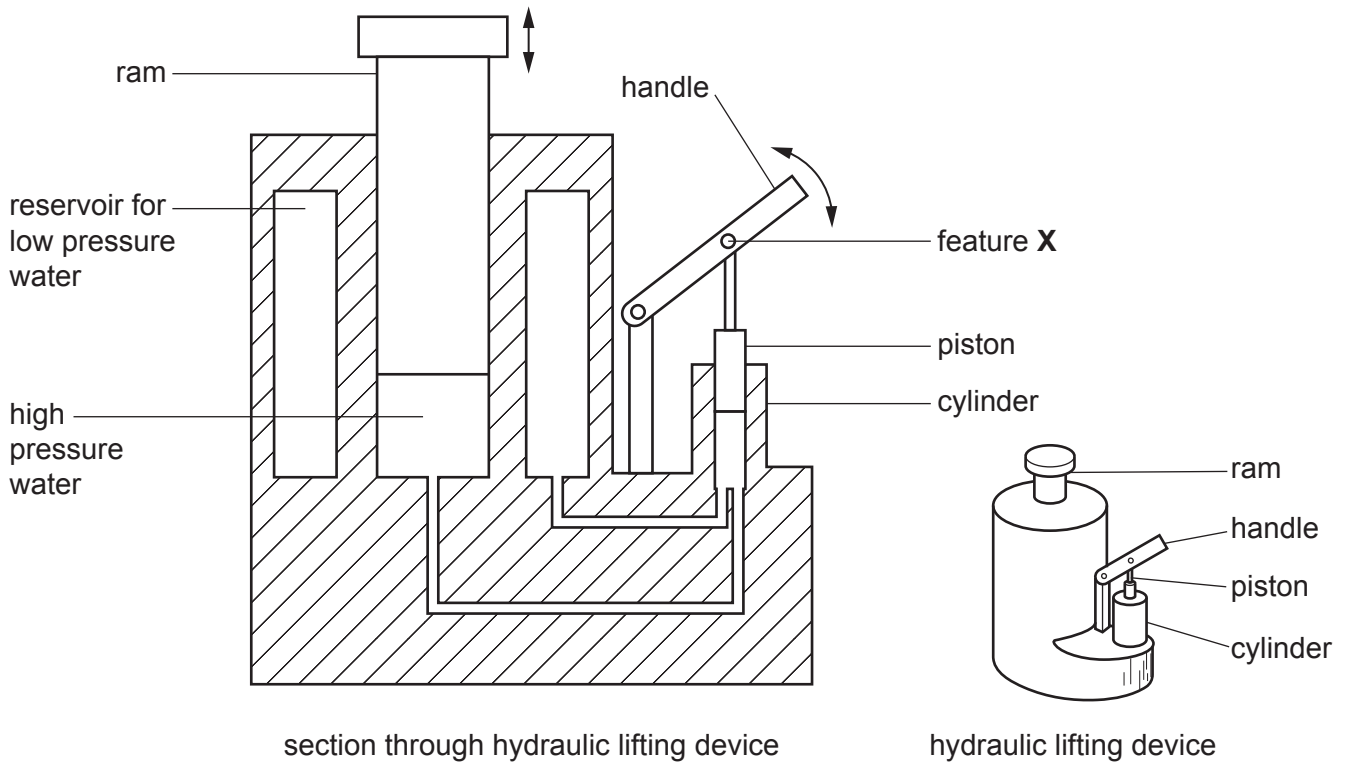

Fig. 6.1

- (a) Explain the function of the design feature shown at X. [2]
- (b) Identify and describe **two** problems with the hydraulic lifting device. [4]
- (c) Use notes and sketches to explain how the design for the hydraulic lifting device would need to be changed to overcome the **two** problems you have identified in **part (b)**. [6]
- (d) Discuss why products, such as the hydraulic lifting device, are tested at regular intervals. Your answer should:
- (i) analyse the given situation and identify **three** relevant issues raised by the question [3]
  - (ii) explain why you consider these issues to be relevant [3]
  - (iii) contain specific examples/evidence to support your conclusions. [2]

## Section C

Answer **one** question from this section on the plain A3 paper provided.

You are provided with two sheets of plain A3 paper. You should use **both** sides of the paper. **Each** of the four parts (a) – (d) of the question you choose to answer should take up one side of paper.

When you are asked to **develop** a design you must show, using notes and sketches, the development and evaluation of a **range** of ideas into a single design solution. The design proposal should be annotated to give details about materials, joining methods and important sizes.

7 Fig. 7.1 shows details for toy storage.

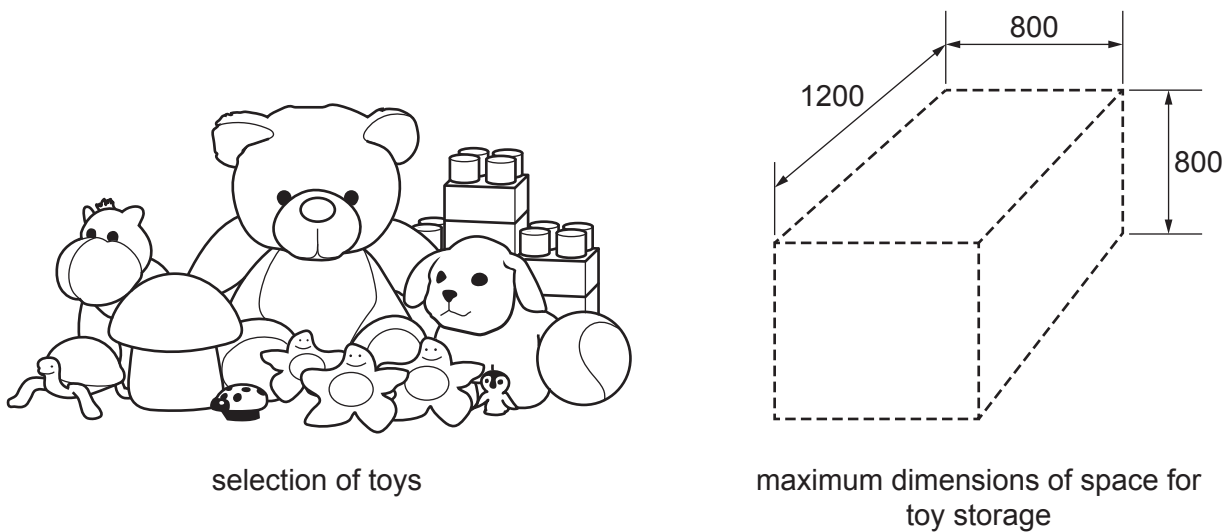
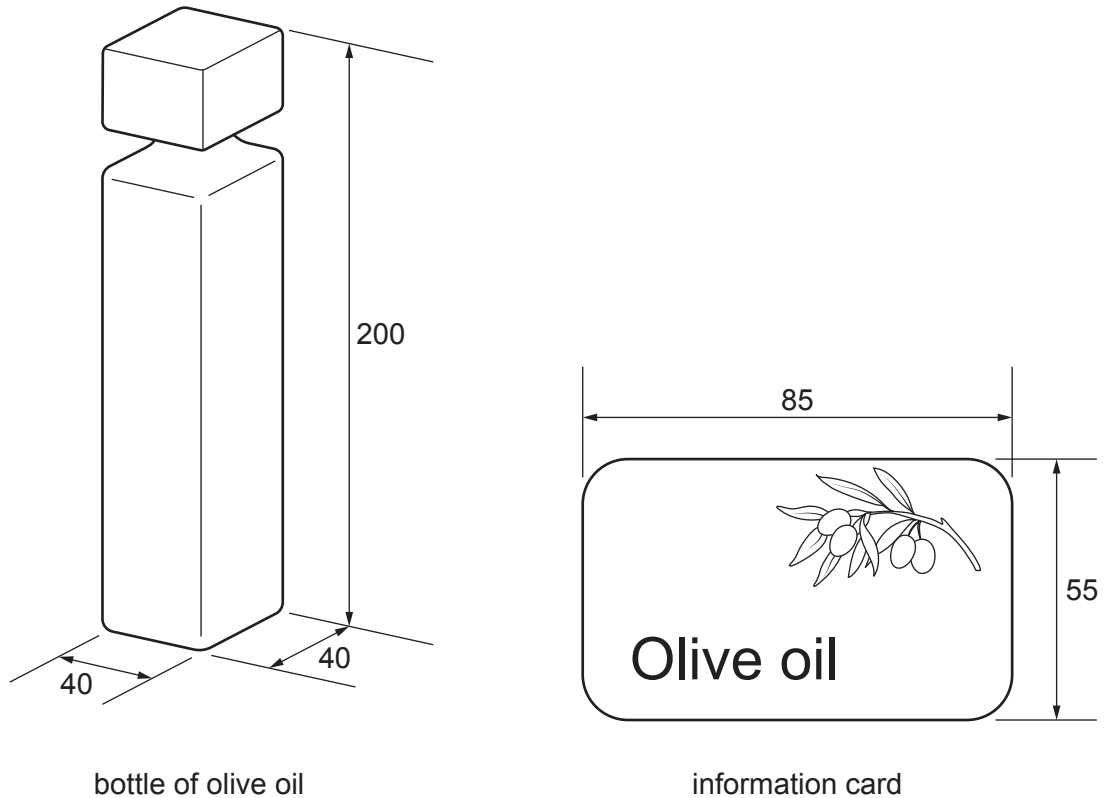

Fig. 7.1

- (a) Use notes and sketches to **develop** a design for toy storage that would be sold as a flat-pack item. The toy storage must have **one** surface that opens fully so that large toys can be removed easily. [20]
- (b) Use notes and sketches to **develop** a design for a device for the toy storage designed in **part (a)** that prevents the opening surface from accidentally being closed. [20]
- (c) Use notes and sketches to **develop** a design for an accessory that allows a parent to personalise the toy storage designed in **part (a)**. [20]
- (d) Produce a pictorial (3D) rendered drawing of the complete toy storage which shows all of the features that you have designed in **parts (a) – (c)**. [20]



8 Fig. 8.1 shows details of a bottle of olive oil and an information card that require packaging.



**Fig. 8.1**

- (a) Use notes and sketches to **develop** a design for a vacuum formed tray to hold and present the bottle of olive oil and the information card in the packaging. [20]
- (b) Use notes and sketches to **develop** a design for a one-piece development (net) for packaging to hold the vacuum formed tray designed in **part (a)**. The development (net) must allow the bottle of olive oil and the information card to be seen when in the packaging. [20]
- (c) Use notes and sketches to **develop** a design for a name and colour scheme for the packaging designed in **part (b)**. The name should reflect the link between olive oil and good health. [20]
- (d) Produce a pictorial (3D) rendered drawing of the complete packaging which shows all of the features that you have designed in **parts (a) – (c)**. [20]

- 9 Fig. 9.1 shows details of a blister pack with tablets and a container for tablets.

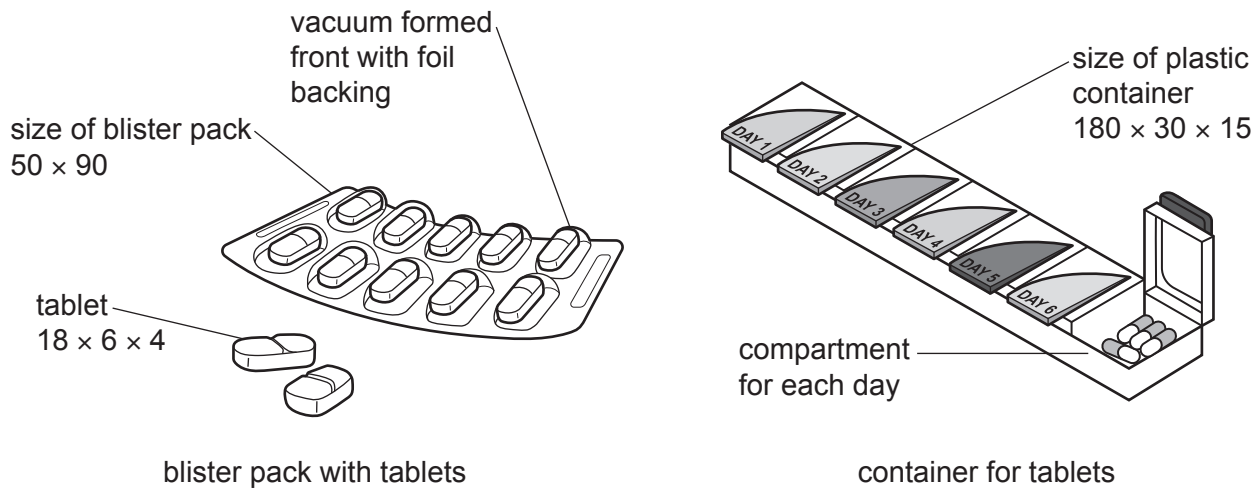

**Fig. 9.1**

- (a) Use notes and sketches to **develop** a design for a device to remove individual tablets from the blister pack. The device must be designed for use by a person with limited hand movement. [20]
- (b) Use notes and sketches to **develop** a design for an attachment for the device designed in **part (a)** that will guide a tablet into a compartment in the container for tablets. [20]
- (c) Use notes and sketches to **develop** a design for an attachment to the device designed in **part (a)** that will allow it to be easily located if misplaced in the home. [20]
- (d) Produce a pictorial (3D) rendered drawing of the device to remove tablets from the blister pack which shows all of the features that you have designed in **parts (a) – (c)**. [20]



**BLANK PAGE**

---

Permission to reproduce items where third-party owned material protected by copyright is included has been sought and cleared where possible. Every reasonable effort has been made by the publisher (UCLES) to trace copyright holders, but if any items requiring clearance have unwittingly been included, the publisher will be pleased to make amends at the earliest possible opportunity.

To avoid the issue of disclosure of answer-related information to candidates, all copyright acknowledgements are reproduced online in the Cambridge Assessment International Education Copyright Acknowledgements Booklet. This is produced for each series of examinations and is freely available to download at [www.cambridgeinternational.org](http://www.cambridgeinternational.org) after the live examination series.

Cambridge Assessment International Education is part of Cambridge Assessment. Cambridge Assessment is the brand name of the University of Cambridge Local Examinations Syndicate (UCLES), which is a department of the University of Cambridge.