



Cambridge International AS & A Level

DESIGN & TECHNOLOGY

9705/32

Paper 3

May/June 2024

3 hours



You must answer on the answer booklet/paper.

You will need: Answer booklet/paper Coloured pencils
A3 drawing paper (5 sheets)
A range of design drawing equipment

INSTRUCTIONS

- Answer **three** questions in total:
 - Section A: answer **two** questions from **one** of the Parts A, B or C.
 - Section B: answer **one** question.
- If you have been given an answer booklet, follow the instructions on the front cover of the answer booklet.
- Use a black or dark blue pen.
- Write your name, centre number and candidate number on all the work you hand in.
- Do **not** use an erasable pen or correction fluid.
- You may use an HB pencil, or coloured pencils as appropriate, for any diagrams, graphs or rough working.
- At the end of the examination, fasten all your work together. Do **not** use staples, paper clips or glue.

INFORMATION

- The total mark for this paper is 120.
- The number of marks for each question or part question is shown in brackets [].
- All dimensions are in millimetres.

This document has **12** pages. Any blank pages are indicated.

Section A

Answer **two** questions from **one** of the Parts **A**, **B** or **C**.

Part A – Product Design

The instruction ‘discuss’ denotes that you should:

- examine critically the issues raised by the question
- explain and interpret these issues as appropriate
- introduce evidence wherever possible to support conclusions of arguments.

1 Fig. 1.1 shows details of a spinning die to be used with board games.

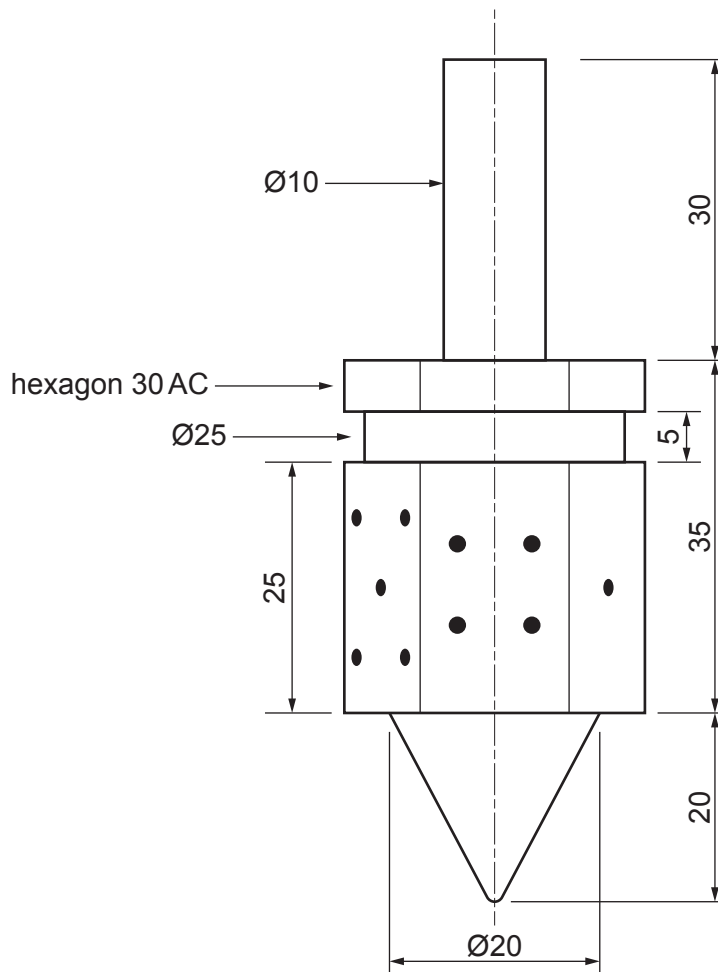
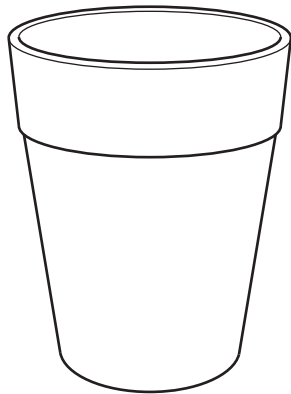

Fig. 1.1

- (a) State a suitable material for a spinning die of the type shown in Fig. 1.1 and give **two** reasons for your choice. [3]
- (b) Use sketches and notes to describe how you would make a spinning die in a school workshop. Ignore the number of dots on the die. [9]
- (c) Explain the changes which may be necessary to the design, the manufacturing method used and the material selected, if 100 identical spinning dice were required. Use sketches and notes to support your answer. [8]

- 2 Discuss how manufacturers meet the needs and demands of consumers in a rapidly changing product market. [20]

3



item: beaker
process: compression moulding

item: scriber point
process: hardening and tempering

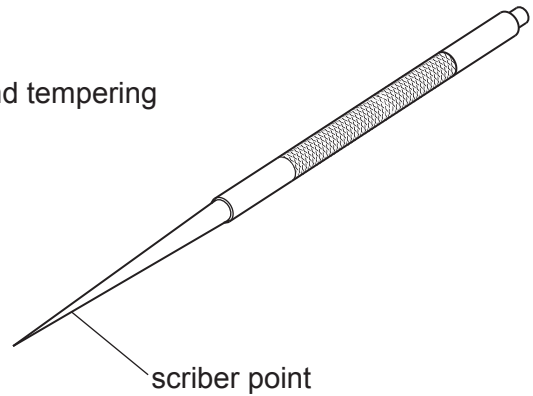

scriber point

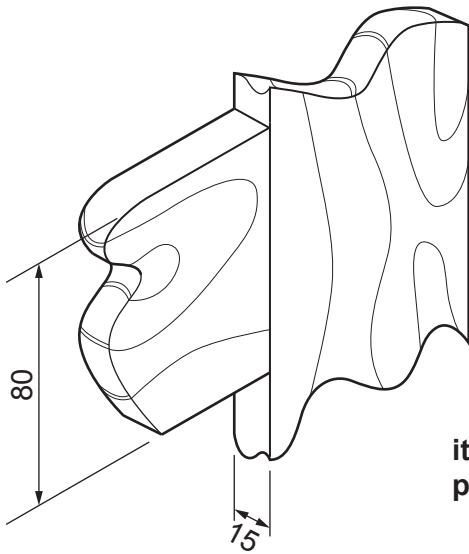

item: furniture joint
process: dowelling

Fig. 3.1

Choose **two** of the items shown in Fig. 3.1. For **each**:

- (a) use sketches and notes to describe how the process has been used in the manufacture of the item. [14]
- (b) explain why the process is particularly suitable for the production of the item. [6]

Part B – Practical Technology

The instruction 'discuss' denotes that you should:

- examine critically the issues raised by the question
- explain and interpret these issues as appropriate
- introduce evidence wherever possible to support conclusions of arguments.

4 Fig. 4.1 shows a wall rack to hold kitchen implements.

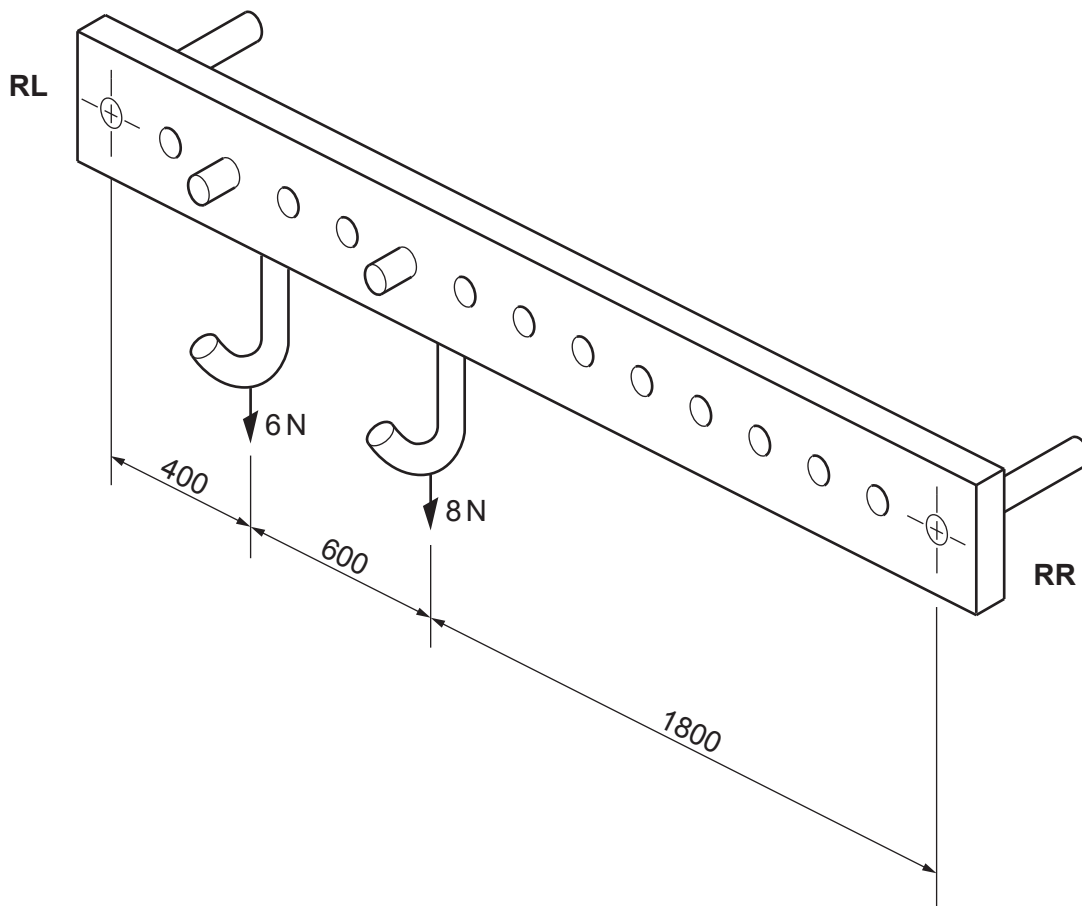

Fig. 4.1

- (a) (i) Use moments to calculate the reactions at **RL** and **RR**. [4]
- (ii) Use graphical means to confirm the reactions at **RL** and **RR**. [6]
- (b) Discuss the importance of quality control when manufacturing wall racks. [10]
- 5 Discuss how technological developments in interfacing, between a computer and input and output devices, have impacted product design. [20]

6 (a) (i) Calculate the current through a resistor if the voltage is 9V and the resistance is $500\ \Omega$. [3]

(ii) Calculate the output voltage V_{out} of the circuit shown in Fig. 6.1. [3]

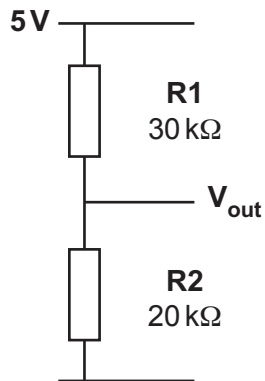

Fig. 6.1

(b) A truth table for four logic gates **A**, **B**, **C** and **D** is given below.

Name and draw the symbol for each gate.

Inputs		Outputs			
		A	B	C	D
0	0	0	1	1	0
0	1	0	1	0	1
1	0	0	1	0	1
1	1	1	0	0	0

[8]

(c) Explain the working of and give an example for a:

- reed switch
- relay.

[6]

Part C – Graphic Products

The instruction 'discuss' denotes that you should:

- examine critically the issues raised by the question
- explain and interpret these issues as appropriate
- introduce evidence wherever possible to support conclusions of arguments.

7 Fig. 7.1 shows orthographic views of a camera.

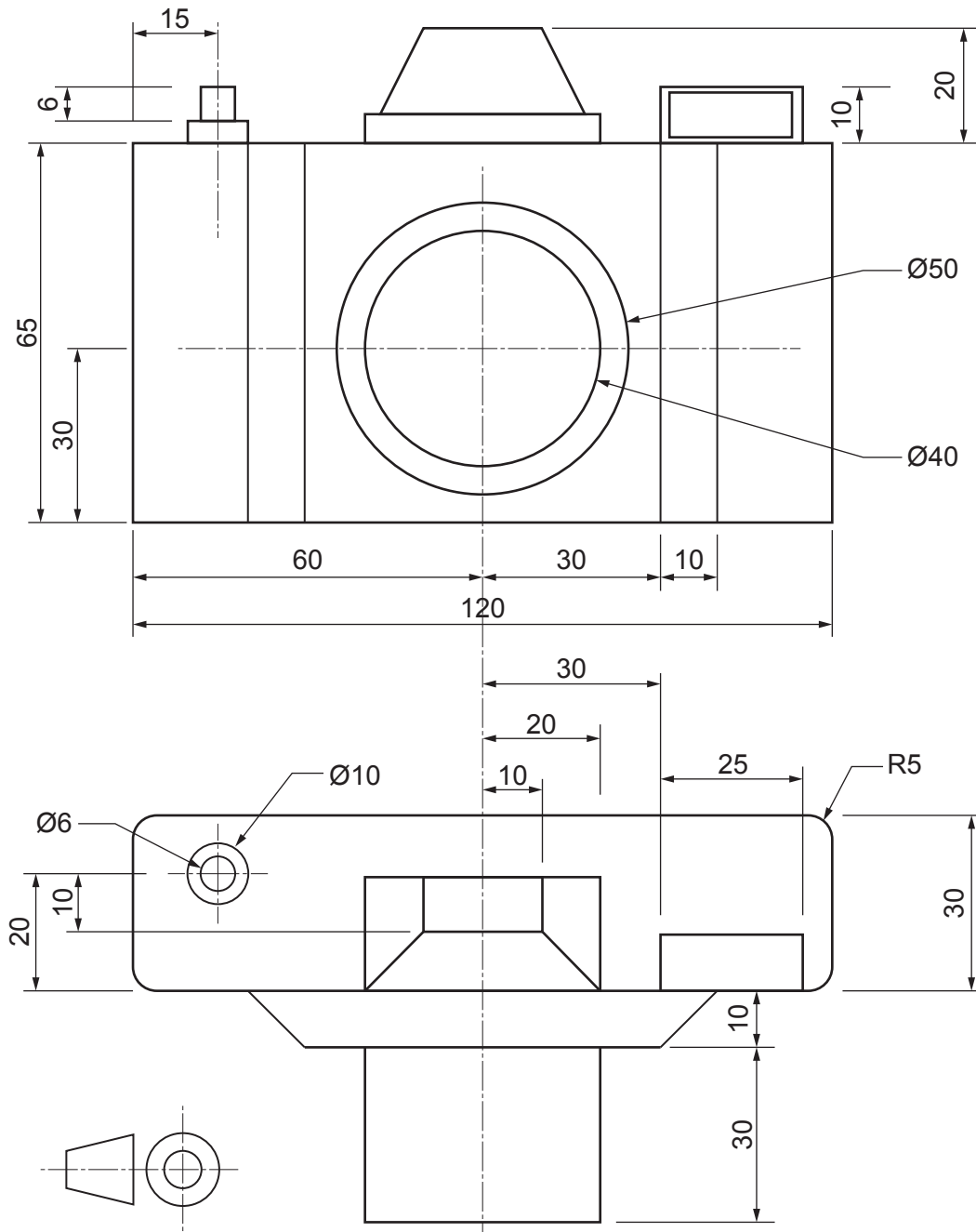

Fig. 7.1

Draw a full-size isometric drawing of the camera. Assume any dimensions not given.

[20]

- 8 Discuss the importance of 'visual impact' when designing graphic products. [20]
- 9 Fig. 9.1 shows a prototype for the packaging for a smart bulb. [9]

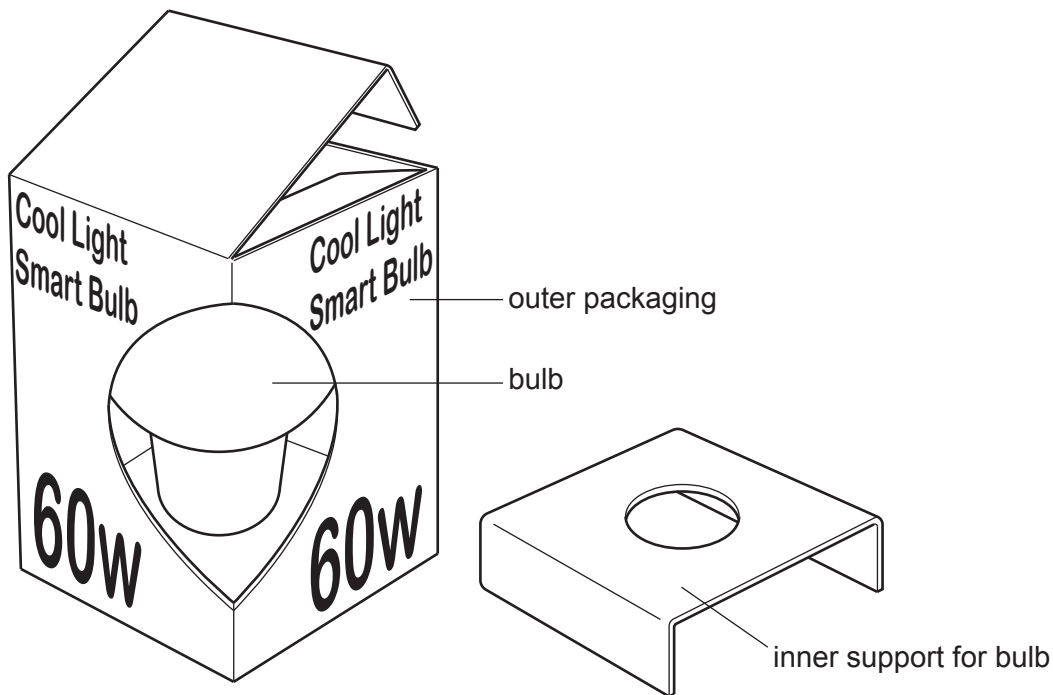

Fig. 9.1

- (a) State a suitable material for the outer packaging of the smart bulb and give **two** reasons for your choice. [3]
- (b) Use sketches and notes to show how you would make the prototype of the outer packaging **and** the inner support, to show to a client. [9]
- (c) Explain the changes which may be necessary to the design, the manufacturing method used and the material selected, if 10 000 identical packages were required. Use sketches and notes to support your answer. [8]

Section B

Answer **one** question on the A3 paper provided.

Each question is worth 80 marks.

You should approach the design question of your choice in the following manner:

Analysis

Produce an analysis of the given situation/problem, which may be in written or graphical form. [5]

Specification

From the analysis produce a detailed written specification of the design requirements. Include at least five specification points other than those given in the question. [5]

Exploration

Use bold sketches and brief notes to show your exploration of ideas for a design solution, with reasons for selection. [25]

Development

Show using bold sketches and notes, the development, reasoning and composition of ideas into a single design proposal. Give details of materials, constructional and other relevant technical details. [25]

Proposed solution

Produce drawings of an appropriate kind to show the complete solution. [15]

Evaluation

Give a written evaluation of the final design solution. [5]

- 10 A company wants to extend its product range by introducing a dual-purpose furniture unit for students living in university accommodation. A unit that would incorporate a bed and study area is proposed.

You are to design a dual-purpose furniture unit to provide both a sleeping area and an area to study for university students.

The unit must:

- be easy to assemble
- include storage space for stationery and books.

Details of student university accommodation are given in Fig. 10.1.

Estimate any dimensions not shown.

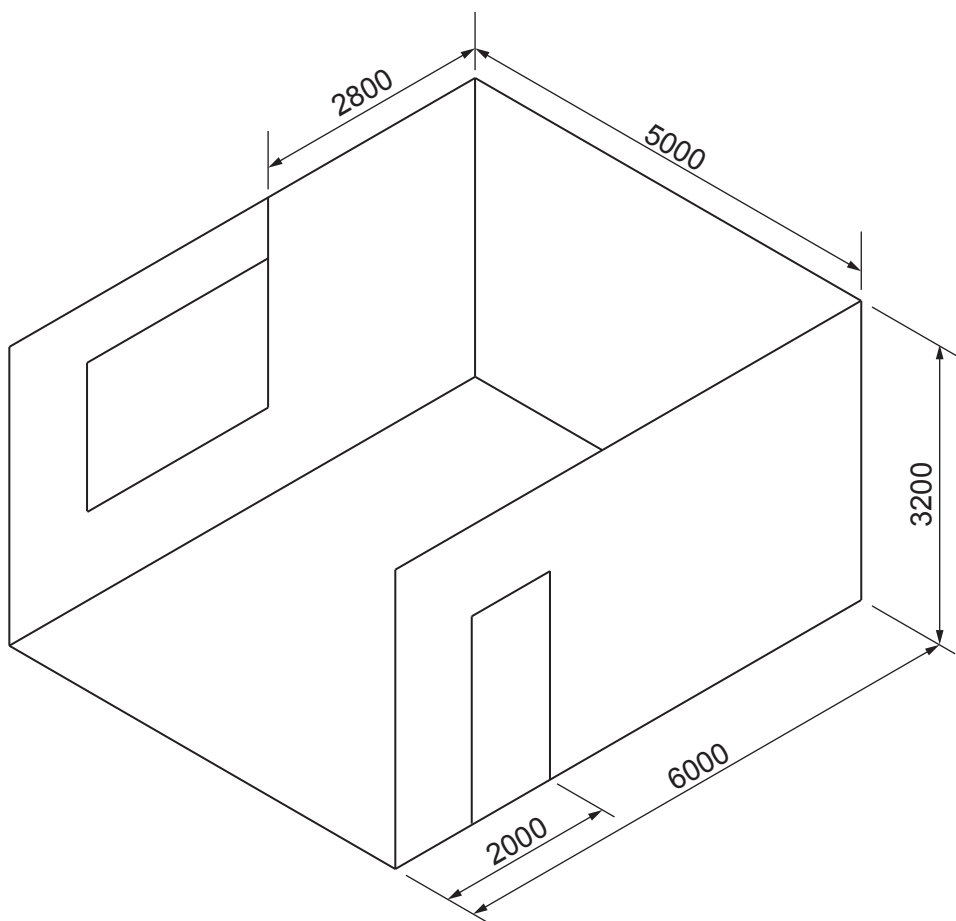

Fig. 10.1

[80]

- 11 A school for children aged 11 to 14 years is to run a cycling safety club. The school will create an obstacle course in the playground with similar size and shape obstacles, where children will learn how to safely control a bicycle.

You are to design an obstacle.

The obstacle must:

- make a sound and/or lighting effect if touched by the cyclist
- be easy to store.

[80]

- 12 A music festival has food stalls selling snacks. The stalls will sell a sandwich wrap, a can of drink and a cookie as a packaged meal.

You are to design the packaging for the three items.

The packaging must:

- include a name and logo to reflect the music festival
- be designed as flat-pack to assemble at the music festival.

Details of the items to be included are given in Fig. 12.1.

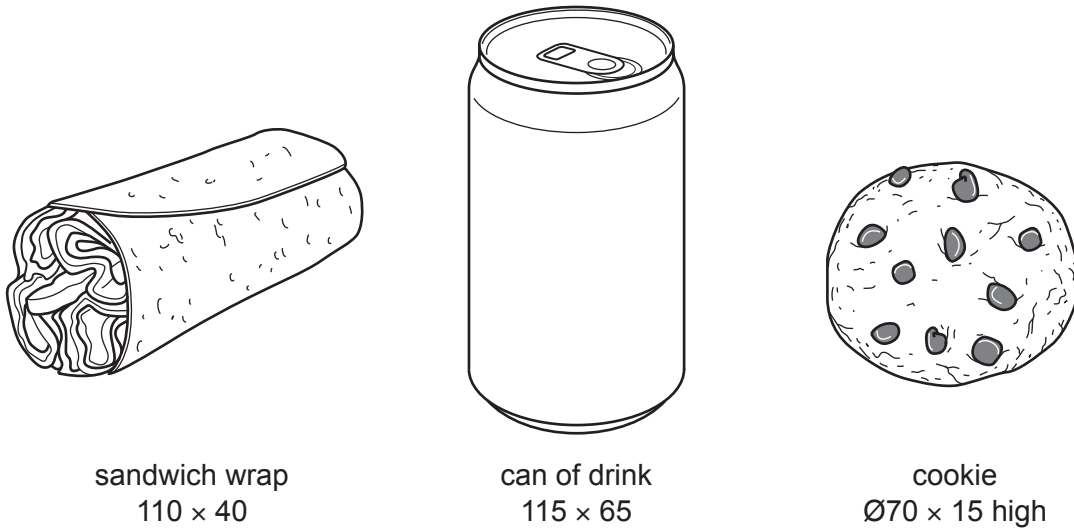

Fig. 12.1

[80]

BLANK PAGE

Permission to reproduce items where third-party owned material protected by copyright is included has been sought and cleared where possible. Every reasonable effort has been made by the publisher (UCLES) to trace copyright holders, but if any items requiring clearance have unwittingly been included, the publisher will be pleased to make amends at the earliest possible opportunity.

To avoid the issue of disclosure of answer-related information to candidates, all copyright acknowledgements are reproduced online in the Cambridge Assessment International Education Copyright Acknowledgements Booklet. This is produced for each series of examinations and is freely available to download at www.cambridgeinternational.org after the live examination series.

Cambridge Assessment International Education is part of Cambridge Assessment. Cambridge Assessment is the brand name of the University of Cambridge Local Examinations Syndicate (UCLES), which is a department of the University of Cambridge.