



UNIVERSITY OF CAMBRIDGE INTERNATIONAL EXAMINATIONS
General Certificate of Education
Advanced Subsidiary Level and Advanced Level

www.PapaCambridge.com

MATHEMATICS

9709/01

Paper 1 Pure Mathematics 1 (P1)

October/November 2008

1 hour 45 minutes

Additional Materials: Answer Booklet/Paper
 Graph Paper
 List of Formulae (MF9)

* 4 0 5 0 6 7 1 5 7 5 *

READ THESE INSTRUCTIONS FIRST

If you have been given an Answer Booklet, follow the instructions on the front cover of the Booklet.

Write your Centre number, candidate number and name on all the work you hand in.

Write in dark blue or black pen.

You may use a soft pencil for any diagrams or graphs.

Do not use staples, paper clips, highlighters, glue or correction fluid.

Answer **all** the questions.

Give non-exact numerical answers correct to 3 significant figures, or 1 decimal place in the case of angles in degrees, unless a different level of accuracy is specified in the question.

The use of an electronic calculator is expected, where appropriate.

You are reminded of the need for clear presentation in your answers.

At the end of the examination, fasten all your work securely together.

The number of marks is given in brackets [] at the end of each question or part question.

The total number of marks for this paper is 75.

Questions carrying smaller numbers of marks are printed earlier in the paper, and questions carrying larger numbers of marks later in the paper.

This document consists of **4** printed pages.

1 Find the value of the coefficient of x^2 in the expansion of $\left(\frac{x}{2} + \frac{2}{x}\right)^6$.

2 Prove the identity

$$\frac{1 + \sin x}{\cos x} + \frac{\cos x}{1 + \sin x} \equiv \frac{2}{\cos x}. \quad [4]$$

3 The first term of an arithmetic progression is 6 and the fifth term is 12. The progression has n terms and the sum of all the terms is 90. Find the value of n . [4]

4

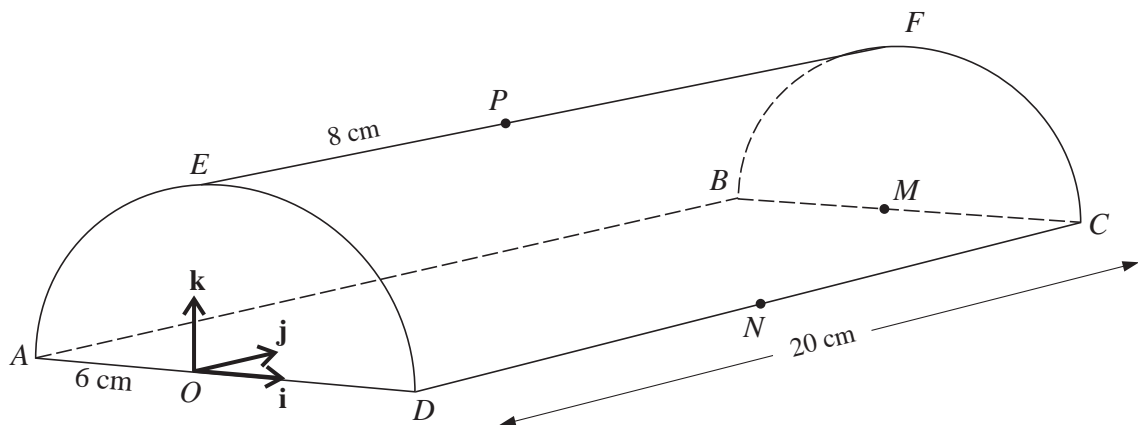

The diagram shows a semicircular prism with a horizontal rectangular base $ABCD$. The vertical ends AED and BFC are semicircles of radius 6 cm. The length of the prism is 20 cm. The mid-point of AD is the origin O , the mid-point of BC is M and the mid-point of DC is N . The points E and F are the highest points of the semicircular ends of the prism. The point P lies on EF such that $EP = 8$ cm.

Unit vectors \mathbf{i} , \mathbf{j} and \mathbf{k} are parallel to OD , OM and OE respectively.

(i) Express each of the vectors \overrightarrow{PA} and \overrightarrow{PN} in terms of \mathbf{i} , \mathbf{j} and \mathbf{k} . [3]

(ii) Use a scalar product to calculate angle APN . [4]

5 The function f is such that $f(x) = a - b \cos x$ for $0^\circ \leq x \leq 360^\circ$, where a and b are positive constants. The maximum value of $f(x)$ is 10 and the minimum value is -2 .

(i) Find the values of a and b . [3]

(ii) Solve the equation $f(x) = 0$. [3]

(iii) Sketch the graph of $y = f(x)$. [2]

3

6

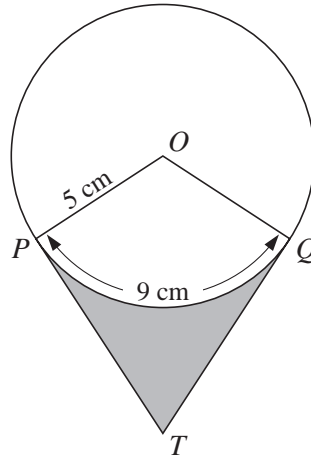

In the diagram, the circle has centre O and radius 5 cm. The points P and Q lie on the circle, and the arc length PQ is 9 cm. The tangents to the circle at P and Q meet at the point T . Calculate

- (i) angle POQ in radians, [2]
- (ii) the length of PT , [3]
- (iii) the area of the shaded region. [3]

7

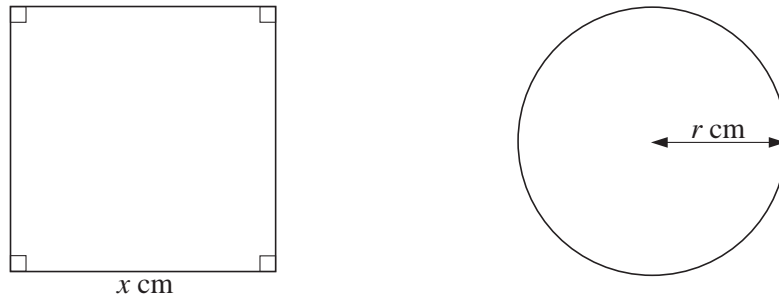

A wire, 80 cm long, is cut into two pieces. One piece is bent to form a square of side x cm and the other piece is bent to form a circle of radius r cm (see diagram). The total area of the square and the circle is A cm².

- (i) Show that $A = \frac{(\pi + 4)x^2 - 160x + 1600}{\pi}$. [4]
- (ii) Given that x and r can vary, find the value of x for which A has a stationary value. [4]

8 The equation of a curve is $y = 5 - \frac{8}{x}$.

- (i) Show that the equation of the normal to the curve at the point $P(2, 1)$ is $2y + x = 4$. [4]

This normal meets the curve again at the point Q .

- (ii) Find the coordinates of Q . [3]
- (iii) Find the length of PQ . [2]

9

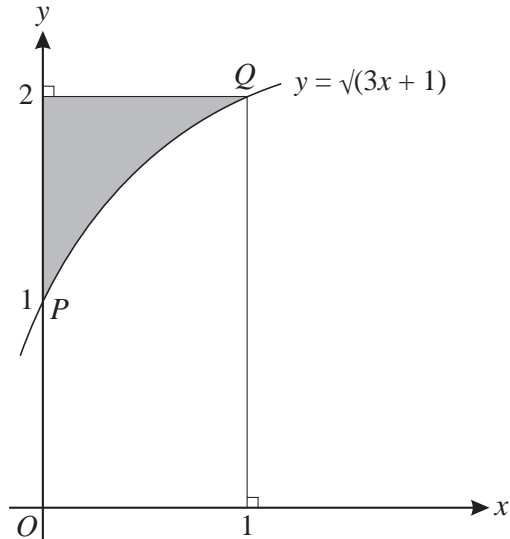

The diagram shows the curve $y = \sqrt{3x + 1}$ and the points $P(0, 1)$ and $Q(1, 2)$ on the curve. The shaded region is bounded by the curve, the y -axis and the line $y = 2$.

(i) Find the area of the shaded region. [4]

(ii) Find the volume obtained when the shaded region is rotated through 360° about the x -axis. [4]

Tangents are drawn to the curve at the points P and Q .

(iii) Find the acute angle, in degrees correct to 1 decimal place, between the two tangents. [4]

10 The function f is defined by

$$f : x \mapsto 3x - 2 \text{ for } x \in \mathbb{R}.$$

(i) Sketch, in a single diagram, the graphs of $y = f(x)$ and $y = f^{-1}(x)$, making clear the relationship between the two graphs. [2]

The function g is defined by

$$g : x \mapsto 6x - x^2 \text{ for } x \in \mathbb{R}.$$

(ii) Express $gf(x)$ in terms of x , and hence show that the maximum value of $gf(x)$ is 9. [5]

The function h is defined by

$$h : x \mapsto 6x - x^2 \text{ for } x \geq 3.$$

(iii) Express $6x - x^2$ in the form $a - (x - b)^2$, where a and b are positive constants. [2]

(iv) Express $h^{-1}(x)$ in terms of x . [3]