



UNIVERSITY OF CAMBRIDGE INTERNATIONAL EXAMINATIONS
General Certificate of Education
Advanced Subsidiary Level and Advanced Level

CANDIDATE
NAME

CENTRE
NUMBER

--	--	--	--	--

CANDIDATE
NUMBER

--	--	--	--



PHYSICS

9702/23

Paper 2 AS Structured Questions

October/November 2011

1 hour

Candidates answer on the Question Paper.

No Additional Materials are required.

READ THESE INSTRUCTIONS FIRST

Write your Centre number, candidate number and name on all the work you hand in.

Write in dark blue or black pen.

You may use a soft pencil for any diagrams, graphs or rough working.

Do not use staples, paper clips, highlighters, glue or correction fluid.

DO NOT WRITE IN ANY BARCODES.

Answer **all** questions.

You may lose marks if you do not show your working or if you do not use appropriate units.

At the end of the examination, fasten all your work securely together.

The number of marks is given in brackets [] at the end of each question or part question.

For Examiner's Use	
1	
2	
3	
4	
5	
6	
Total	

This document consists of **15** printed pages and **1** blank page.



Data

speed of light in free space,	$c = 3.00 \times 10^8 \text{ m s}^{-1}$
permeability of free space,	$\mu_0 = 4\pi \times 10^{-7} \text{ H m}^{-1}$
permittivity of free space,	$\epsilon_0 = 8.85 \times 10^{-12} \text{ F m}^{-1}$
elementary charge,	$e = 1.60 \times 10^{-19} \text{ C}$
the Planck constant,	$h = 6.63 \times 10^{-34} \text{ J s}$
unified atomic mass constant,	$u = 1.66 \times 10^{-27} \text{ kg}$
rest mass of electron,	$m_e = 9.11 \times 10^{-31} \text{ kg}$
rest mass of proton,	$m_p = 1.67 \times 10^{-27} \text{ kg}$
molar gas constant,	$R = 8.31 \text{ J K}^{-1} \text{ mol}^{-1}$
the Avogadro constant,	$N_A = 6.02 \times 10^{23} \text{ mol}^{-1}$
the Boltzmann constant,	$k = 1.38 \times 10^{-23} \text{ J K}^{-1}$
gravitational constant,	$G = 6.67 \times 10^{-11} \text{ N m}^2 \text{ kg}^{-2}$
acceleration of free fall,	$g = 9.81 \text{ m s}^{-2}$

Formulae

uniformly accelerated motion,

$$s = ut + \frac{1}{2}at^2$$

$$v^2 = u^2 + 2as$$

work done on/by a gas,

$$W = p\Delta V$$

gravitational potential,

$$\phi = -\frac{Gm}{r}$$

hydrostatic pressure,

$$p = \rho gh$$

pressure of an ideal gas,

$$p = \frac{1}{3} \frac{Nm}{V} \langle c^2 \rangle$$

simple harmonic motion,

$$a = -\omega^2 x$$

velocity of particle in s.h.m.,

$$v = v_0 \cos \omega t$$

$$v = \pm \omega \sqrt{(x_0^2 - x^2)}$$

electric potential,

$$V = \frac{Q}{4\pi\epsilon_0 r}$$

capacitors in series,

$$1/C = 1/C_1 + 1/C_2 + \dots$$

capacitors in parallel,

$$C = C_1 + C_2 + \dots$$

energy of charged capacitor,

$$W = \frac{1}{2} QV$$

resistors in series,

$$R = R_1 + R_2 + \dots$$

resistors in parallel,

$$1/R = 1/R_1 + 1/R_2 + \dots$$

alternating current/voltage,

$$x = x_0 \sin \omega t$$

radioactive decay,

$$x = x_0 \exp(-\lambda t)$$

decay constant,

$$\lambda = \frac{0.693}{t_{\frac{1}{2}}}$$

Answer **all** the questions in the spaces provided.

- 1 (a) Distinguish between scalars and vectors.

.....
 [1]

- (b) Underline **all** the vector quantities in the list below.

acceleration kinetic energy momentum power weight [2]

- (c) A force of 7.5N acts at 40° to the horizontal, as shown in Fig. 1.1.

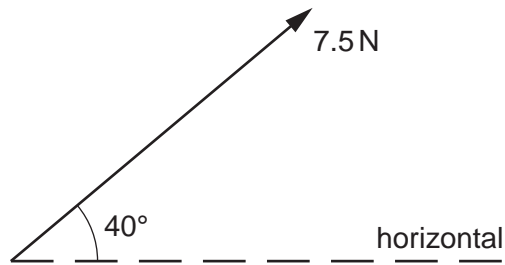

Fig. 1.1

Calculate the component of the force that acts

- (i) horizontally,

horizontal component = N [1]

- (ii) vertically.

vertical component = N [1]

- (d) Two strings support a load of weight 7.5 N, as shown in Fig. 1.2.

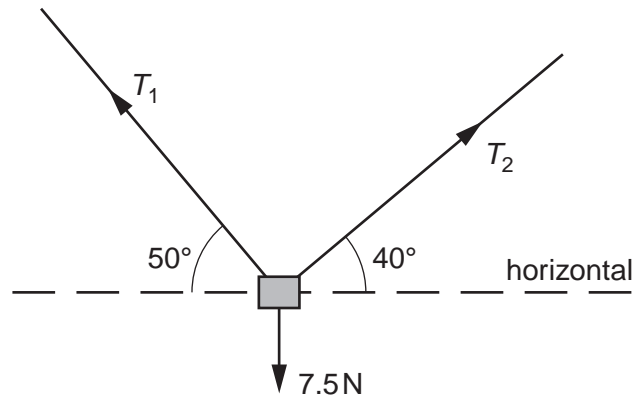

Fig. 1.2

One string has a tension T_1 and is at an angle 50° to the horizontal. The other string has a tension T_2 and is at an angle 40° to the horizontal. The object is in equilibrium. Determine the values of T_1 and T_2 by using a vector triangle or by resolving forces.

$$T_1 = \dots\dots\dots \text{ N}$$

$$T_2 = \dots\dots\dots \text{ N}$$

[4]

2 The variation with time t of velocity v of a car is shown in Fig. 2.1.

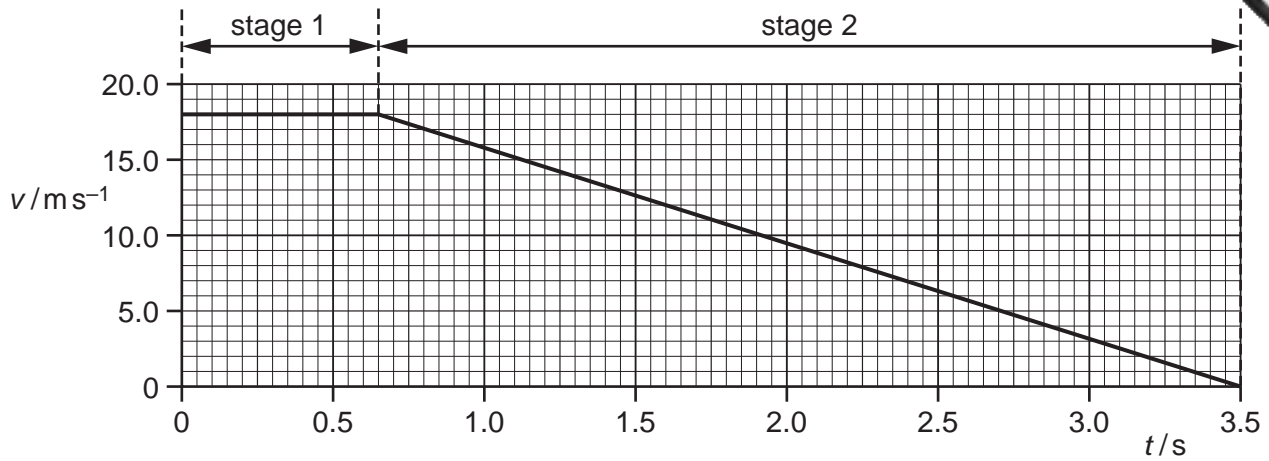

Fig. 2.1

At time $t = 0$, the driver sees an obstacle in the road. A short time later, the driver applies the brakes. The car travels in two stages, as shown in Fig. 2.1.

(a) Use Fig. 2.1 to describe the velocity of the car in

1. stage 1,

.....
 [1]

2. stage 2.

.....
 [1]

(b) (i) Calculate the distance travelled by the car from $t = 0$ to $t = 3.5$ s.

total distance = m [2]



- (ii) The car has a total mass of 1250 kg. Determine the total resistive force acting on the car in stage 2.

force = N [3]

- (c) For safety reasons drivers are asked to travel at lower speeds. For each stage, describe and explain the effect on the distance travelled for the same car and driver travelling at half the initial speed shown in Fig. 2.1.

- (i) stage 1:

.....
.....
..... [1]

- (ii) stage 2:

.....
.....
.....
..... [2]

3 (a) Define the terms

(i) *power*,

..... [1]

(ii) the *Young modulus*.

.....

 [1]

(b) A crane is used to lift heavy objects, as shown in Fig. 3.1.

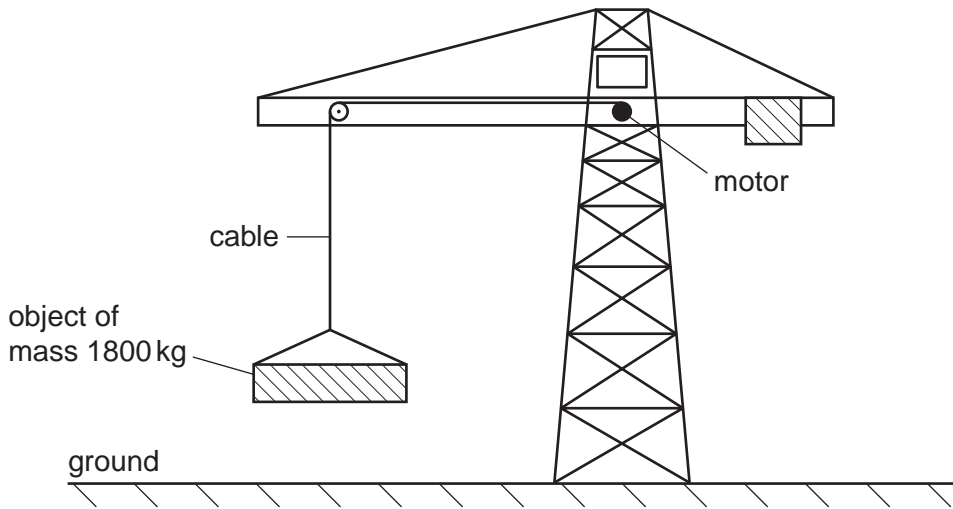

Fig. 3.1

The motor in the crane lifts a total mass of 1800 kg from rest on the ground. The cable supporting the mass is made of steel of Young modulus 2.4×10^{11} Pa. The cross-sectional area of the cable is 1.3×10^{-4} m². As the mass leaves the ground, the strain in the cable is 0.0010. Assume the weight of the cable to be negligible.

(i) 1. Use the Young Modulus of the steel to show that the tension in the cable is 3.1×10^4 N.

[2]

2. Calculate the acceleration of the mass as it is lifted from the ground.

acceleration = ms⁻² [3]

- (ii) The motor now lifts the mass through a height of 15 m at a constant speed.

Calculate

1. the tension in the lifting cable,

tension = N [1]

2. the gain in potential energy of the mass.

gain in potential energy = J [2]

- (iii) The motor of the crane is 30% efficient. Calculate the input power to the motor required to lift the mass at a constant speed of 0.55 m s^{-1} .

input power = W [3]

- 4 (a) Distinguish between *potential difference* (p.d.) and *electromotive force* (e.m.f.) in terms of energy transformations.

.....

.....

.....

..... [2]

- (b) Two cells A and B are connected in series with a resistor R of resistance $5.5\ \Omega$, as shown in Fig. 4.1.

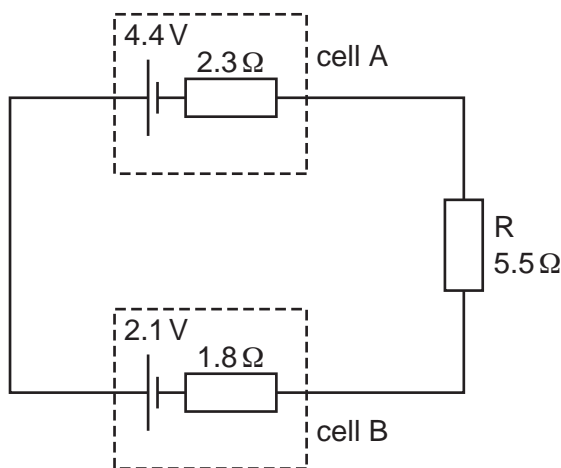

Fig. 4.1

Cell A has e.m.f. 4.4V and internal resistance $2.3\ \Omega$. Cell B has e.m.f. 2.1V and internal resistance $1.8\ \Omega$.

- (i) State Kirchhoff's second law.

.....

..... [1]

- (ii) Calculate the current in the circuit.

current = A [2]

- (iii) On Fig. 4.1, draw an arrow to show the direction of the current in the circuit. Label this arrow *I*. [1]

(iv) Calculate

1. the p.d. across resistor R,

p.d. = V [1]

2. the terminal p.d. across cell A,

p.d. = V [1]

3. the terminal p.d. across cell B.

p.d. = V [2]

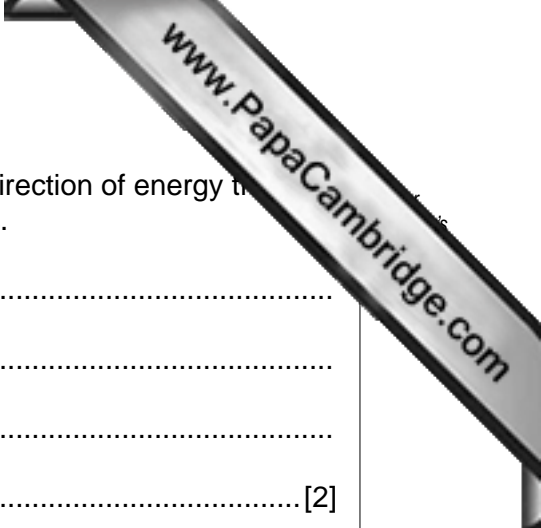

- 5 (a) By reference to vibrations of the points on a wave and to its direction of energy transfer, distinguish between transverse waves and longitudinal waves.

.....

 [2]

- (b) Describe what is meant by a *polarised* wave.

.....

 [2]

- (c) The variation with distance x of the displacement y of a transverse wave is shown in Fig. 5.1.

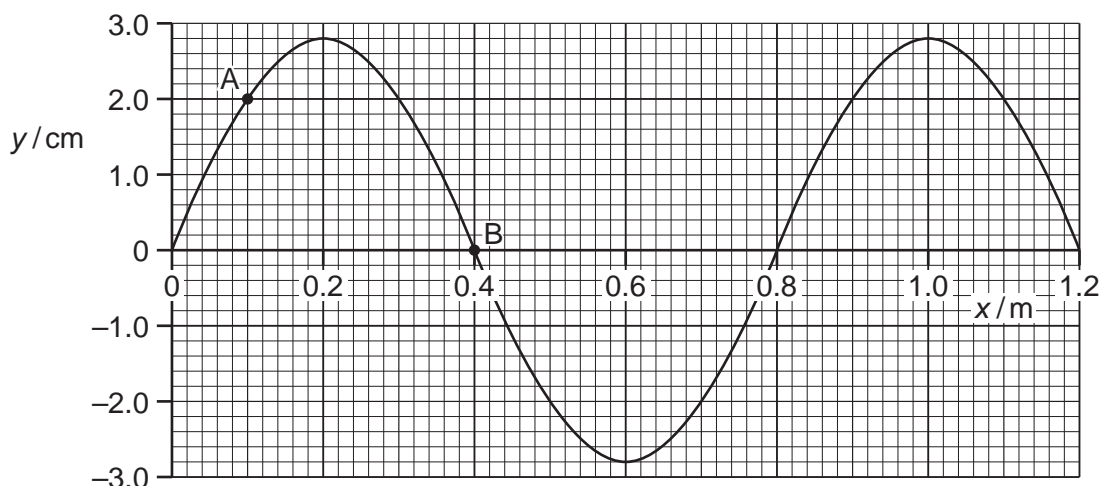

Fig. 5.1

- (i) Use Fig. 5.1 to determine

1. the amplitude of the wave,

amplitude = cm [1]

2. the phase difference between the points labelled A and B.

phase difference = [2]

- (ii) Determine the amplitude of a wave with twice the intensity of that shown in Fig. 5.1.

amplitude = cm [1]

- 6 Two horizontal metal plates are separated by distance d in a vacuum. A potential difference is applied across the plates, as shown in Fig. 6.1.

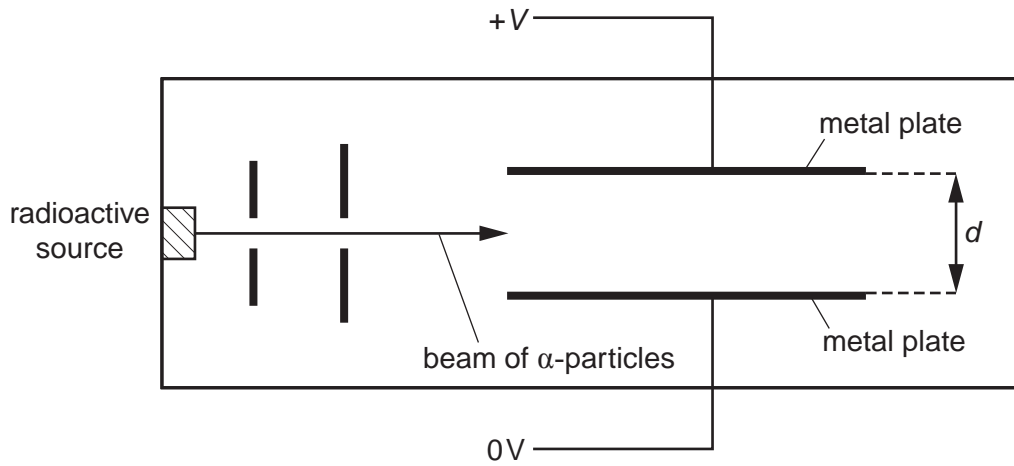

Fig. 6.1

A horizontal beam of α -particles from a radioactive source is made to pass between the plates.

- (a) State and explain the effect on the deflection of the α -particles for each of the following changes:

- (i) The magnitude of V is increased.

.....
 [1]

- (ii) The separation d of the plates is decreased.

.....
 [1]



(b) The source of α -particles is replaced with a source of β -particles. Compare, with a reason in each case, the effect of each of the following properties on the deflections of α - and β -particles in a uniform electric field:

(i) charge

.....
.....
..... [2]

(ii) mass

.....
.....
..... [2]

(iii) speed

.....
.....
..... [1]

(c) The electric field gives rise to an acceleration of the α -particles and the β -particles. Determine the ratio

$$\frac{\text{acceleration of the } \alpha\text{-particles}}{\text{acceleration of the } \beta\text{-particles}}$$

ratio = [3]

