



UNIVERSITY OF CAMBRIDGE INTERNATIONAL EXAMINATIONS
General Certificate of Education
Advanced Subsidiary Level and Advanced Level

www.PapaCambridge.com

PHYSICS

9702/36

Paper 3 Advanced Practical Skills 2

October/November 2012

CONFIDENTIAL INSTRUCTIONS

*
2
0
2
8
8
9
5
1
9
4
*

Great care should be taken to ensure that any confidential information given does not reach the candidates either directly or indirectly.

No access to the Question Paper is permitted in advance of the examination.

If you have any problems or queries regarding these Instructions, please contact CIE
by e-mail: international@cie.org.uk,
by phone: +44 1223 553554,
by fax: +44 1223 553558,
stating the Centre number, the nature of the query and the syllabus number quoted above.

This document consists of **8** printed pages.



Preparing apparatus

These instructions detail the apparatus required for the experiments in the Question Paper. It is essential that absolute confidentiality is maintained in advance of the examination: the content of these instructions must not be revealed either directly or indirectly to candidates.

No access is permitted to the Question Paper in advance of the examination.

If you have problems or queries regarding these instructions, please contact CIE:

by e-mail: international@cie.org.uk,
or by telephone: +44 1223 553554,
or by fax: +44 1223 553558,

stating the nature of the query and quoting the syllabus and paper numbers (9702/36).

It is assumed that the ordinary apparatus of a Physics laboratory will be available.

Number of sets of apparatus

The number of sets of apparatus provided for each experiment should be $\frac{1}{2}N$, where N is the number of candidates taking the examination. There should, in addition, be a few spare sets of apparatus available in case problems arise during the examination.

Organisation of the examination

Candidates should be allowed access to the apparatus for each experiment for one hour only. After spending one hour on one experiment, candidates should change over to the other experiment. The order in which a candidate attempts the two experiments is immaterial.

Assistance to Candidates

Candidates should be informed that, if they find themselves in real difficulty, they may ask the Supervisor for practical assistance, but that the extent of this assistance will be reported to the Examiner, who may make a deduction of marks.

Assistance should only be given:

when it is asked for by a candidate,
or as directed in the Notes sections of these instructions,
or where apparatus is seen to have developed a fault.

Assistance should be restricted to enabling candidates to make observations and measurements. Observations and measurements must not be made for candidates, and no help should be given with data analysis or evaluation.

All assistance given to candidates must be reported on the Supervisor's Report Form.

Faulty apparatus

In cases of faulty apparatus (not arising from a candidate's mishandling) that prevent the required measurements being taken, the Supervisor may allow extra time to give the candidate a fair opportunity to perform the experiment as if the fault had not been present. The candidate should use a spare copy of the Question Paper when the fault has been rectified or when working with a second set of apparatus.

Supervisor's Report

The Supervisor should complete the Supervisor's Report Form on pages 7 and 8 and enclose it in the envelope containing the answers of the candidates. If more than one envelope is used, a copy of the report must be enclosed in each envelope.

Question 1**Apparatus requirements (per set of apparatus unless otherwise specified)**

Thin card of approximate dimensions 3 cm × 3 cm with a pinhole of approximate diameter 1 mm through its centre.

Sheet of black paper. See Note 1.

Adhesive tape (e.g. Sellotape). See Notes 1 and 4.

Black PVC insulating tape. See Note 2.

6V d.c. power supply with switch.

6V, 0.06A MES lamp in holder (e.g. RS Components 655-9643) with 30 cm leads. See Note 2.

Ohmmeter with 20 k Ω and 200 k Ω ranges. See Note 5.

CdS light-dependent resistor (LDR) (e.g. RS Components 651-507) with 80 cm leads. See Notes 3 and 4.

Two half-metre rules with millimetre scales. See Note 4.

Notes

- 1 An A4 size sheet would be suitable. Use the adhesive tape and black paper to make a tube of length 30 cm and diameter approximately 3 cm. The diameter of the tube must be greater than the width of the half-metre rule.
- 2 Attach leads to the lamp holder for connection to the power supply. Insert the lamp into one end of the paper tube and seal it with black PVC tape to prevent entry of light from the sides or the back.
- 3 Solder leads to the LDR and provide suitable connections to the ohmmeter.
- 4 Assemble the apparatus as shown in Fig. 1.1. The LDR should be fixed at the 0 cm end of one of the half-metre rules with its window facing away along the axis of the rule. If the half-metre rule has two scales, then the unused scale should be concealed.

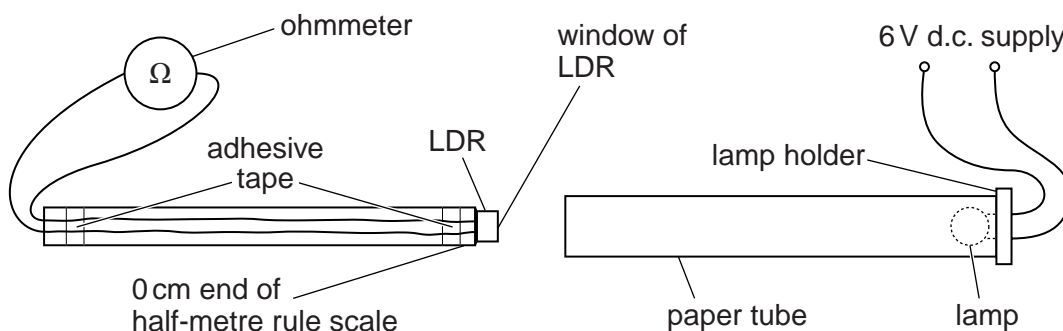
**Fig. 1.1**

- 5 The ohmmeter should be initially set to the 20 k Ω range. (If a multimeter is used, it should be limited to the 20 k Ω and 200 k Ω ranges, and any unused terminals should be covered.)
- 6 The apparatus should be laid on the bench. If it is to be used by another candidate, then it should be restored to its original state, with the ohmmeter set to the 20 k Ω range.

Information required by Examiners

Sample set of numerical results, clearly labelled "Supervisor's Results" and obtained out of sight of the

Question 2**Apparatus requirements (per set of apparatus unless otherwise specified)**

Cylindrical container of water with diameter in the range 30 mm to 50 mm and height at least 30 cm (e.g. a measuring cylinder). It should be transparent or translucent. See Note 1.

Transparent beaker or other container of sufficient volume to contain the water from the cylindrical container.

Piece of modelling clay (e.g. Plasticine) of mass 25 g. See Note 2.

20 g mass (e.g. two 10 g slotted masses). See Note 3.

Small paper clip. See Note 3.

Thin string or strong thread of length approximately 90 cm. See Note 3.

Stopwatch reading to 0.1 s or better.

Stand of height at least 70 cm.

Pulley suitable for attaching to the stand.

Half-metre rule with a millimetre scale.

Paper towels.

30 cm ruler with a millimetre scale.

Information card. See Note 1.

Notes

- Two waterproof marks should be made on the cylindrical container as shown in Fig. 2.1.

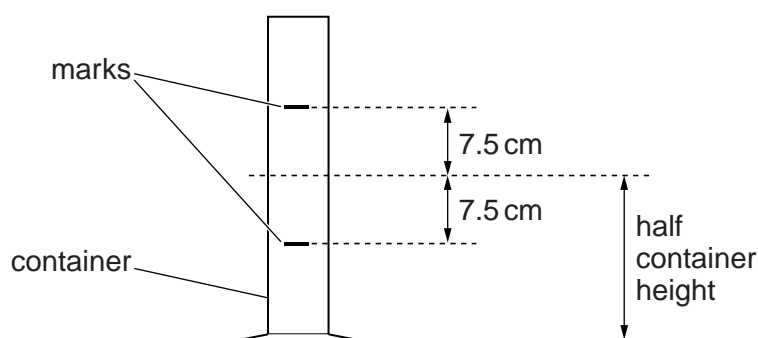

Fig. 2.1

The average internal diameter d_0 of the container should be determined by measuring the volume V of water between the marks and then using $d_0 = \sqrt[3]{(4V/15\pi)}$ where V is in cm^3 and d_0 is in cm.

The candidate should be provided with a card on which are written the values d_0 , A and B . For example, $d_0 = 3.8$ cm, $A = 0.95d_0$ and $B = 0.88d_0$. All values should be given to the nearest millimetre. Fig. 2.2 shows an example card.

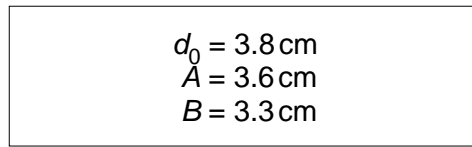

Fig. 2.2

- 2 The modelling clay should be water-resistant and non-absorbent, and stiff enough to retain its shape at room temperature.
- 3 The paper clip should be tied to one end of the string and the 20 g mass tied to the other end. The 20 g mass should be labelled X.
- 4 Assemble the apparatus as shown in Fig. 2.3.

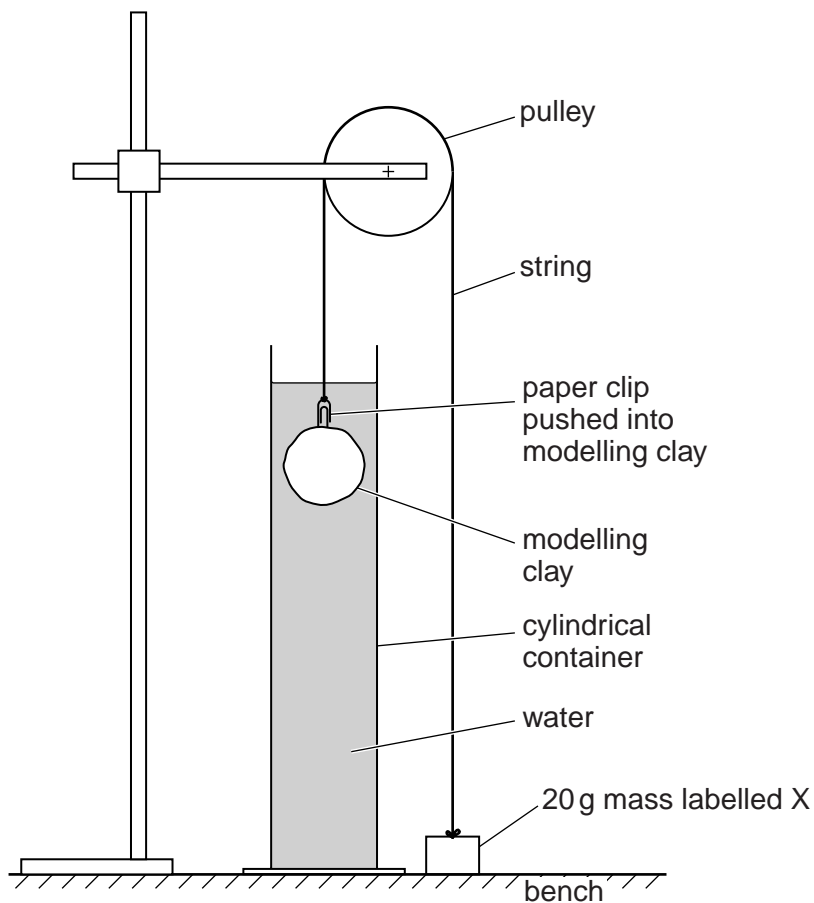

Fig. 2.3

Raise the 20 g mass until the modelling clay reaches the bottom of the container. Release the mass to check that it can raise the modelling clay past the marks to the top. You may need to attach one or more paper clips to the 20 g mass to achieve this.

Detach the piece of modelling clay from the paper clip and place it on paper towels next to the apparatus.

- 5 If the apparatus is to be used by a second candidate, then it should be returned to its original position with the ball of modelling clay placed on new paper towels.

Information required by Examiners

Sample set of numerical results, clearly labelled “Supervisor’s Results” and obtained out of sight of the candidates.



This form should be completed and sent to the Examiner with the scripts.

SUPERVISOR'S REPORT FORM

General Certificate of Education Advanced Subsidiary Level and Advanced Level

October/November Session 2012

The Supervisor's Report should give full details of:

- (a) any help given to a candidate (including the nature of the help given and the name and candidate number of the candidate);
- (b) any cases of faulty apparatus (including the nature of the problem, the action taken to rectify it, any additional time allowed, and the name and candidate number of the candidate);
- (c) any accidents that occurred during the examination;
- (d) any other difficulties experienced by candidates, or any other information that is likely to assist the Examiner, especially if this information cannot be discovered in the scripts.

Cases of individual hardship, such as illness, bereavement or disability, should be reported direct to CIE on the normal Special Consideration form.

Information required by Examiners

For each question, please enclose a sample set of numerical results, obtained out of sight of the candidates and clearly labelled "Supervisor's Results".

Supervisor's Report



Supervisor's Report (continued)



Declaration

(to be signed by the Supervisor)

The preparation of this practical examination has been carried out so as to maintain fully the security of the examination.

Signed

Name

Centre number

Name of Centre

