



Cambridge International AS & A Level

CANDIDATE
NAME

--

CENTRE
NUMBER

--	--	--	--	--	--

CANDIDATE
NUMBER

--	--	--	--	--	--



PHYSICS

9702/23

Paper 2 AS Level Structured Questions

May/June 2024

1 hour 15 minutes

You must answer on the question paper.

No additional materials are needed.

INSTRUCTIONS

- Answer **all** questions.
- Use a black or dark blue pen. You may use an HB pencil for any diagrams or graphs.
- Write your name, centre number and candidate number in the boxes at the top of the page.
- Write your answer to each question in the space provided.
- Do **not** use an erasable pen or correction fluid.
- Do **not** write on any bar codes.
- You may use a calculator.
- You should show all your working and use appropriate units.

INFORMATION

- The total mark for this paper is 60.
- The number of marks for each question or part question is shown in brackets [].

This document has **20** pages. Any blank pages are indicated.

Data

acceleration of free fall	$g = 9.81 \text{ m s}^{-2}$
speed of light in free space	$c = 3.00 \times 10^8 \text{ m s}^{-1}$
elementary charge	$e = 1.60 \times 10^{-19} \text{ C}$
unified atomic mass unit	$1 \text{ u} = 1.66 \times 10^{-27} \text{ kg}$
rest mass of proton	$m_p = 1.67 \times 10^{-27} \text{ kg}$
rest mass of electron	$m_e = 9.11 \times 10^{-31} \text{ kg}$
Avogadro constant	$N_A = 6.02 \times 10^{23} \text{ mol}^{-1}$
molar gas constant	$R = 8.31 \text{ J K}^{-1} \text{ mol}^{-1}$
Boltzmann constant	$k = 1.38 \times 10^{-23} \text{ J K}^{-1}$
gravitational constant	$G = 6.67 \times 10^{-11} \text{ N m}^2 \text{ kg}^{-2}$
permittivity of free space	$\epsilon_0 = 8.85 \times 10^{-12} \text{ F m}^{-1}$ ($\frac{1}{4\pi\epsilon_0} = 8.99 \times 10^9 \text{ m F}^{-1}$)
Planck constant	$h = 6.63 \times 10^{-34} \text{ J s}$
Stefan–Boltzmann constant	$\sigma = 5.67 \times 10^{-8} \text{ W m}^{-2} \text{ K}^{-4}$

Formulae

uniformly accelerated motion	$s = ut + \frac{1}{2}at^2$ $v^2 = u^2 + 2as$
hydrostatic pressure	$\Delta p = \rho g \Delta h$
upthrust	$F = \rho g V$
Doppler effect for sound waves	$f_o = \frac{f_s v}{v \pm v_s}$
electric current	$I = Anvq$
resistors in series	$R = R_1 + R_2 + \dots$
resistors in parallel	$\frac{1}{R} = \frac{1}{R_1} + \frac{1}{R_2} + \dots$

BLANK PAGE

- 1 The drag force F_D acting on a sphere falling through a liquid is given by

$$F_D = 6\pi\eta rv$$

where r is the radius of the sphere,
 v is the speed of the sphere in the liquid and
 η is a property of the liquid called the viscosity.

- (a) Show that the SI base units of viscosity are $\text{kg m}^{-1} \text{s}^{-1}$.

[2]

- (b) The sphere has a radius of 3.0 cm and is falling vertically downwards at a terminal velocity of 2.0 m s^{-1} through the liquid. The drag force acting on the sphere is 0.096 N.

Calculate the viscosity of the liquid.

viscosity = $\text{kg m}^{-1} \text{s}^{-1}$ [2]

- (c) The sphere is shown in Fig. 1.1.

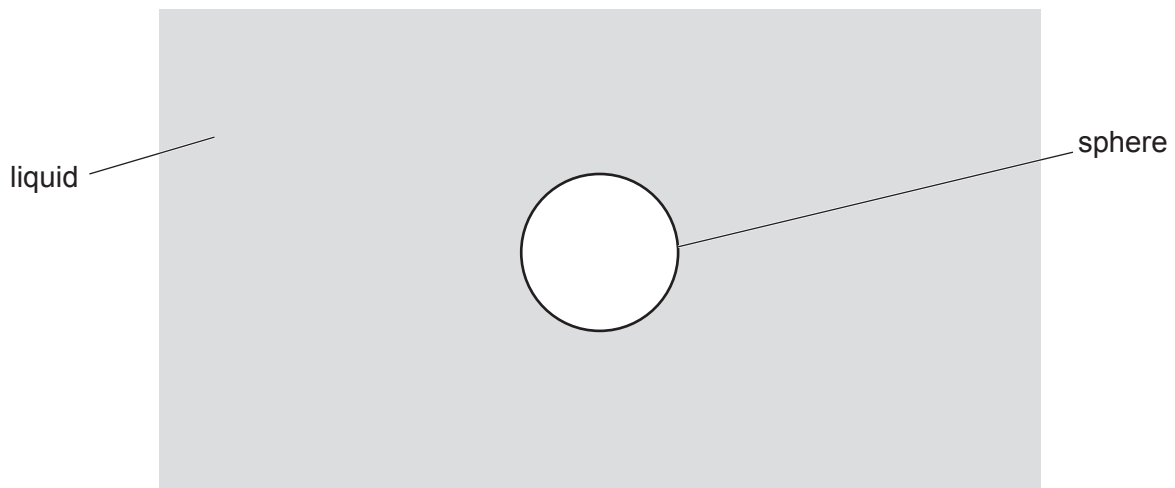

Fig. 1.1

On Fig. 1.1, draw and label arrows to represent the directions of the **three** forces acting on the sphere as it falls at terminal velocity through the liquid. [2]

5

(d) (i) The density of the liquid is 920 kg m^{-3} .

Show that the upthrust acting on the sphere is 1.0 N .

[2]

(ii) Calculate the mass of the sphere.

mass = kg [2]

[Total: 10]

2 (a) Define displacement from a point.

.....
 [1]

(b) An object is projected horizontally at a speed of 6.0 m s^{-1} from a slope, as shown in Fig. 2.1.

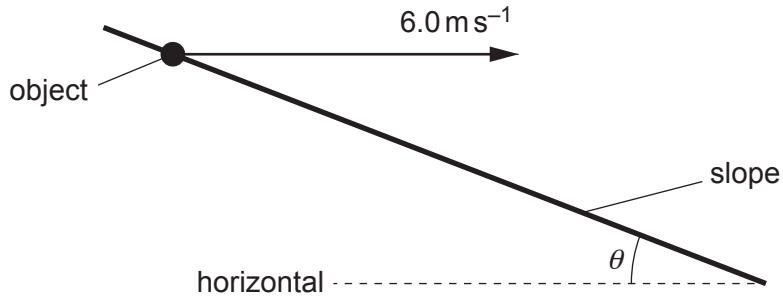

Fig. 2.1 (not to scale)

The slope is at an angle θ to the horizontal. Air resistance is negligible.

The object lands on the slope a time of 0.71 s later and stops without rolling or bouncing.

(i) Determine the horizontal distance travelled by the object.

distance = m [1]

(ii) Determine the vertical distance travelled by the object.

distance = m [2]

(iii) Use your answers in (b)(i) and (b)(ii) to calculate θ .

$$\theta = \dots\dots\dots^\circ \quad [2]$$

(iv) Determine the magnitude of the displacement of the object from its original position.

$$\text{displacement} = \dots\dots\dots \text{ m} \quad [2]$$

(v) By considering energy, calculate the speed of the object just before it lands.

$$\text{speed} = \dots\dots\dots \text{ ms}^{-1} \quad [3]$$

[Total: 11]

- 3 (a) State Hooke's law.

.....
 [1]

- (b) The variation of the applied force with the extension for a sample of a material is shown in Fig. 3.1.

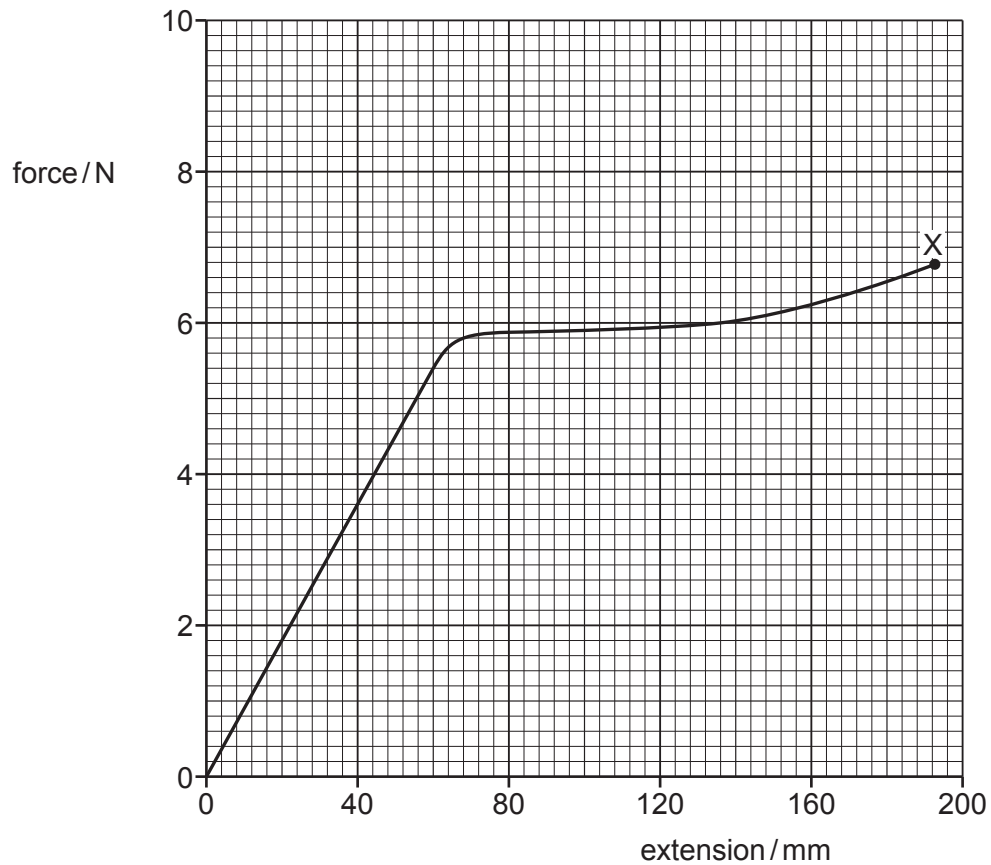

Fig. 3.1

The sample behaves elastically up to an extension of 80 mm and breaks at point X.

- (i) On the line in Fig. 3.1, draw a cross (×) to show the limit of proportionality. Label this cross with the letter P. [1]
- (ii) On the line in Fig. 3.1, draw a cross (×) to show the elastic limit. Label this cross with the letter E. [1]

(c) The sample in (b) has a cross-sectional area of 0.40 mm^2 and an initial length of 3.2 m .

For deformations within the limit of proportionality of the sample, determine:

(i) the spring constant of the sample

spring constant = N m^{-1} [2]

(ii) the Young modulus of the material from which the sample is made.

Young modulus = Pa [3]

(d) Determine an estimate of the work done on the sample as it is extended from zero extension to its breaking point. Explain your reasoning.

work done = J [2]

- (e) A second sample of the same material has a larger cross-sectional area than the original sample but the same initial length. The two samples are each deformed with the limit of proportionality.

State and explain qualitatively how the spring constant of the second sample compares with that of the original sample.

.....

.....

..... [2]

[Total: 12]

4 A progressive transverse wave travelling from left to right is shown at an instant in time in Fig. 4.1.

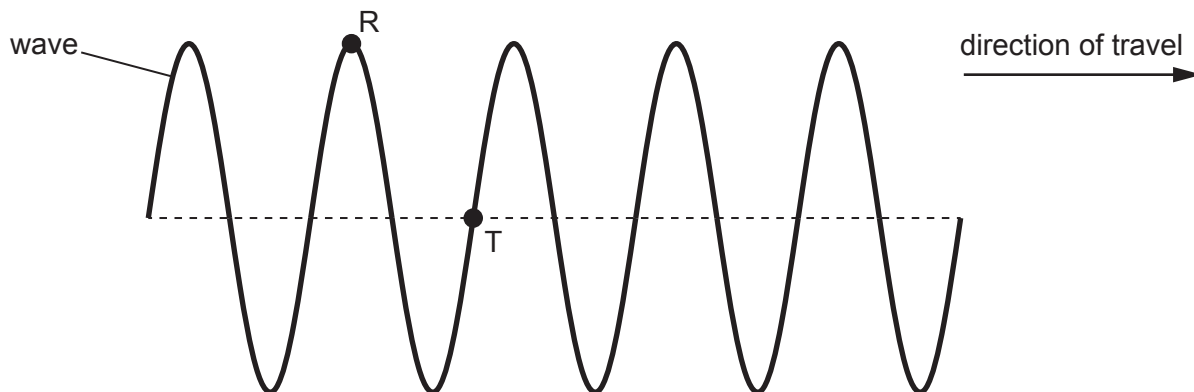

Fig. 4.1

R and T are points on the wave.

(a) State the phase difference between the points R and T.

phase difference = ° [1]

(b) On Fig. 4.1, draw an arrow at point T to show the direction of movement of point T at the instant shown. [1]

(c) The horizontal distance between R and T is 0.62 cm, as shown in Fig. 4.2.

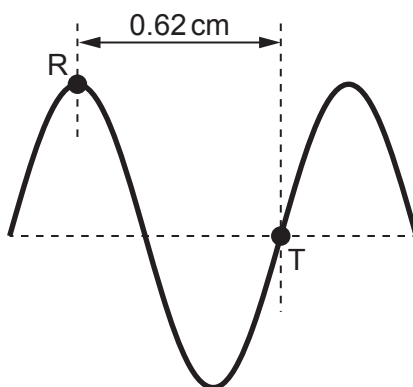

Fig. 4.2 (not to scale)

The speed of the wave is 0.27 ms^{-1} .

Calculate the frequency of the wave.

frequency = Hz [3]

(d) The wave is a water wave produced by a dipper S_1 attached to a vibrator in a ripple tank.

An identical dipper S_2 is attached to the same vibrator. The two dippers produce an interference pattern on the water in the tank, as shown in Fig. 4.3.

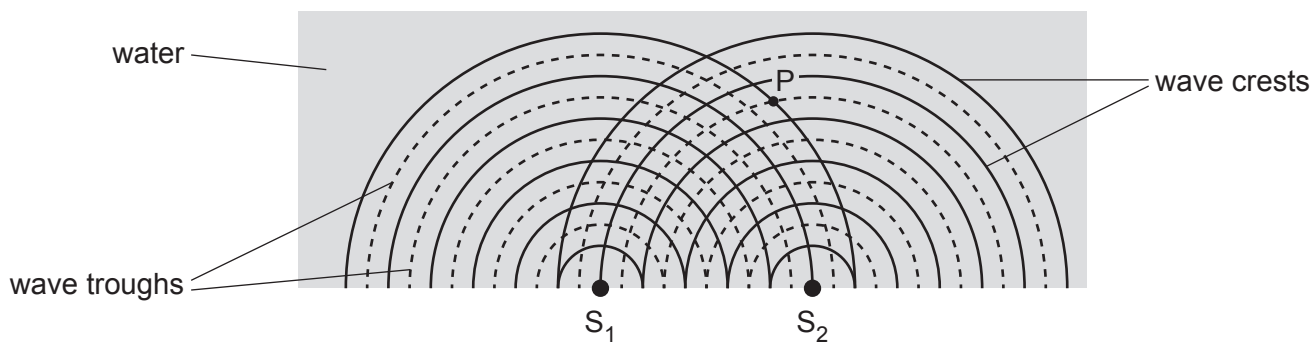

Fig. 4.3 (not to scale)

The wave crests from each source are represented by solid lines on Fig. 4.3 and the wave troughs are represented by dashed lines.

At point P in Fig. 4.3, the wave from S_1 has the same amplitude A as the wave from S_2 .

Describe and explain the amplitude of the resultant wave at point P.

.....

.....

.....

..... [3]

[Total: 8]

5 (a) (i) State Kirchhoff's second law.

.....

 [1]

(ii) State the conservation law that gives rise to Kirchhoff's second law.

..... [1]

(b) A circuit contains a cell of internal resistance r and two resistors of resistances R_1 and R_2 , as shown in Fig. 5.1.

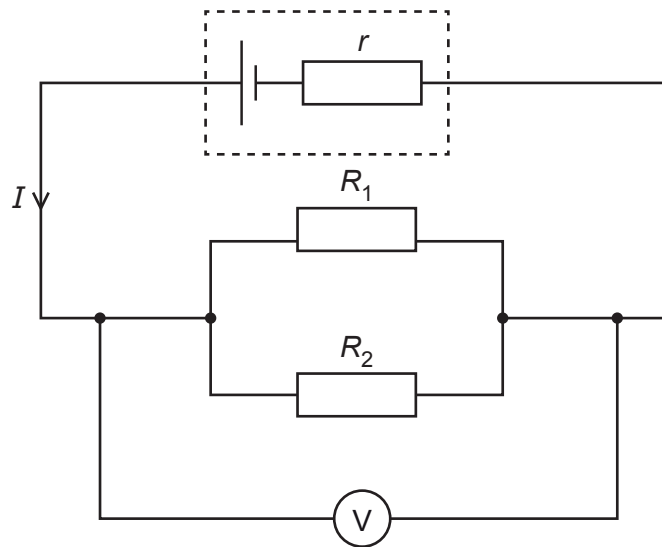

Fig. 5.1

The potential difference (p.d.) across the two resistors is V .

The current in the cell is I .

- (i) Use Kirchhoff's laws to show that the total resistance R_T of the external circuit is given by

$$\frac{1}{R_T} = \frac{1}{R_1} + \frac{1}{R_2}.$$

[2]

- (ii) The electromotive force (e.m.f.) of the cell is 1.50 V.

When the values of R_1 and R_2 are $10\ \Omega$ and $15\ \Omega$ respectively, the p.d. measured by the voltmeter is 1.38 V.

Calculate the internal resistance r of the cell.

$r = \dots\dots\dots\ \Omega$ [3]

(c) A third resistor is added in parallel with R_1 and R_2 in the circuit in Fig. 5.1.

State and explain the effect, if any, of this change on:

(i) the current in the cell

.....
.....
..... [2]

(ii) the p.d. measured by the voltmeter.

.....
.....
..... [2]

[Total: 11]

6 Nuclei of an isotope of samarium (Sm) each contain 62 protons and 85 neutrons.

(a) State the nuclide notation in the form ${}^A_Z\text{X}$ for this isotope of samarium.

[1]

(b) This isotope of samarium is radioactive and decays by emitting particles. Gamma-radiation is **not** emitted. The energy spectrum of the emitted particles is shown in Fig. 6.1.

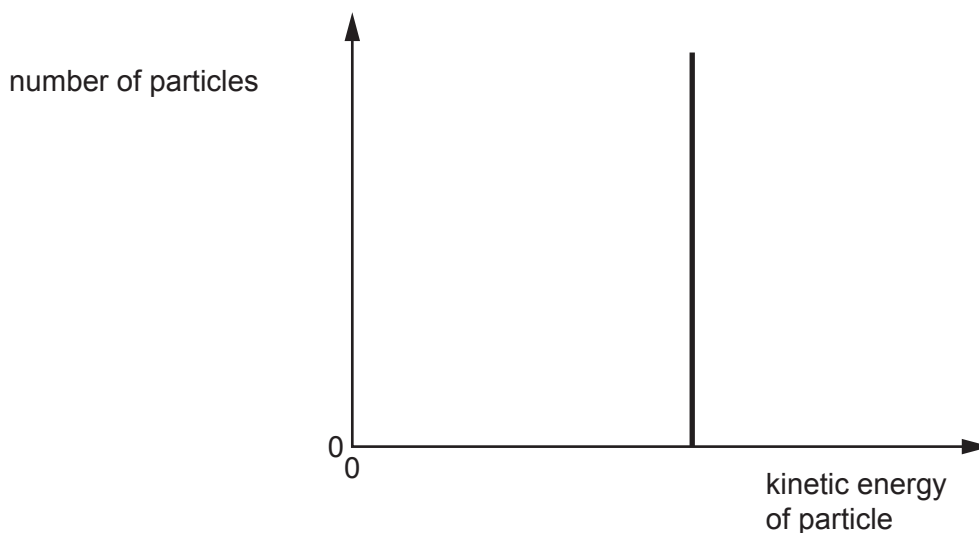

Fig. 6.1

(i) Explain how Fig. 6.1 shows that this isotope of samarium emits α -particles and does **not** emit β -particles.

.....

.....

.....

..... [2]

(ii) This isotope of samarium decays to an isotope of neodymium (Nd).

Give the radioactive decay equation for this decay. Include the nucleon and proton numbers of **all** the particles involved.

[2]

- (c) A baryon is composed of three quarks which all have different flavours. The baryon has a charge of 0.

Two of the quarks in the baryon are an up quark and a bottom quark.

- (i) Determine, in terms of the elementary charge e , the charge on the third quark in the baryon.

charge = e [2]

- (ii) State a possible flavour for the third quark in the baryon.

..... [1]

[Total: 8]

BLANK PAGE

Permission to reproduce items where third-party owned material protected by copyright is included has been sought and cleared where possible. Every reasonable effort has been made by the publisher (UCLES) to trace copyright holders, but if any items requiring clearance have unwittingly been included, the publisher will be pleased to make amends at the earliest possible opportunity.

To avoid the issue of disclosure of answer-related information to candidates, all copyright acknowledgements are reproduced online in the Cambridge Assessment International Education Copyright Acknowledgements Booklet. This is produced for each series of examinations and is freely available to download at www.cambridgeinternational.org after the live examination series.

Cambridge Assessment International Education is part of Cambridge Assessment. Cambridge Assessment is the brand name of the University of Cambridge Local Examinations Syndicate (UCLES), which is a department of the University of Cambridge.