

## Inheritance – 2021 IGCSE 0610

1. Nov/2021/Paper\_11/No.33

An allele is a version of which structure?

- A amino acid
- B chromosome
- C gene
- D protein

2. Nov/2021/Paper\_11/No.34

Which are functions of mitosis?

- 1 growth
- 2 production of gametes
- 3 repair of damaged tissue
- 4 replacement of cells
- 5 asexual reproduction

- A 1, 3, 4 and 5
- B 1 and 3 only
- C 2, 3 and 4
- D 2 only

3. Nov/2021/Paper\_12/No.33

Which of these determine the sex of humans?

- A X and Y genes
- B X and Y alleles
- C X and Y chromosomes
- D X and Y genotypes

4. Nov/2021/Paper\_12/No.34

Part of a tree branch is broken off and planted in the soil. A new tree grows from the branch.

Which row is correct?

	the cells in the new tree are formed by		the cells in the original tree and in the new tree will be genetically	
	meiosis	mitosis	different	identical
<b>A</b>	✓	x	✓	x
<b>B</b>	x	✓	x	✓
<b>C</b>	x	✓	✓	x
<b>D</b>	✓	x	x	✓

key

✓ = correct

x = not correct

5. Nov/2021/Paper\_12/No.35

A species of insect usually has pale-coloured wings. This helps to camouflage them on pale-coloured tree trunks. A few of the insects in this species have darker coloured wings.

After a number of years the tree trunks become darker in colour due to environmental changes. The insects with dark-coloured wings become more common than insects with pale-coloured wings in this species.

Which process causes this change in the proportion of insects with dark-coloured wings?

- A biotechnology
- B conservation
- C natural selection
- D selective breeding

6. Nov/2021/Paper\_13/No.35

A species of insect usually has pale-coloured wings. This helps to camouflage them on pale-coloured tree trunks. A few of the insects in this species have darker coloured wings.

After a number of years the tree trunks become darker in colour due to environmental changes. The insects with dark-coloured wings become more common than insects with pale-coloured wings in this species.

Which process causes this change in the proportion of insects with dark-coloured wings?

- A biotechnology
- B conservation
- C natural selection
- D selective breeding

7. Nov/2021/Paper\_21/No.30

Some descriptions of different human cells are listed.

- 1 contains 46 chromosomes
- 2 haploid nucleus
- 3 diploid nucleus
- 4 contains one set of unpaired chromosomes

Which descriptions are correct for the nucleus of a human gamete?

- A** 1 and 2      **B** 1 and 3      **C** 2 and 4      **D** 3 and 4

8. Nov/2021/Paper\_21/No.31

Which adaptive feature is only found in female gametes?

- A** acrosome containing enzymes
- B** flagellum
- C** jelly coat
- D** nucleus containing chromosomes

9. Nov/2021/Paper\_21/No.32

A man of genotype  $I^A I^B$  and woman of genotype  $I^B i$  have a child.

What is the chance that the child will have the same blood group as one of its parents?

- A** zero      **B** 1 in 4      **C** 1 in 2      **D** 3 in 4

10. Nov/2021/Paper\_22/No.31

Which statement about a diploid human cell is correct?

- A** There are 22 chromosomes and an X or a Y chromosome.
- B** There are 22 pairs of chromosomes and two sex chromosomes.
- C** There are 23 chromosomes.
- D** There are 23 pairs of chromosomes and two sex chromosomes.

11. Nov/2021/Paper\_22/No.32

The gene for haemophilia is found on the X chromosome and the allele for haemophilia is recessive.

In the pedigree diagram the dominant allele is shown as  $X^H$  and the recessive allele is shown as  $X^h$ .

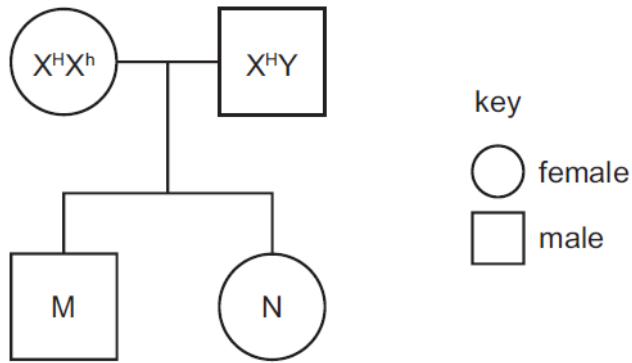

What is the probability of child M having haemophilia?

- A 0.00                      B 0.25                      C 0.50                      D 1.00

12. Nov/2021/Paper\_23/No.34

Which statement about a person who is heterozygous for the sickle-cell allele is correct?

- A They are not resistant to malaria and their genotype is  $Hb^A Hb^S$ .  
B They are not resistant to malaria and their genotype is  $Hb^S Hb^S$ .  
C They are resistant to malaria and their genotype is  $Hb^A Hb^S$ .  
D They are resistant to malaria and their genotype is  $Hb^S Hb^S$ .

(a) A species of pea plant can produce green or yellow peas.

Fig. 3.1 shows a photograph of a green pea and a yellow pea.



Fig. 3.1

The colour of peas is controlled by a single gene:

- The allele for yellow peas is dominant and is represented by the letter **G**.
- The allele for green peas is recessive and is represented by the letter **g**.

(i) Use your knowledge and this information to complete Table 3.1.

Table 3.1

genotype of pea A	
phenotype of pea B	
phenotype of a pea with a heterozygous genotype	

[3]

(ii) Two pea plants were crossed.

Complete the genetic diagram in Fig. 3.2 to show the outcome of the cross.

		parental gametes	
		<b>g</b>	<b>g</b>
parental gametes	<b>G</b>	.....	.....
	<b>g</b>	.....	.....

ratio of yellow offspring : green offspring ..... : .....

[2]

Fig. 3.2

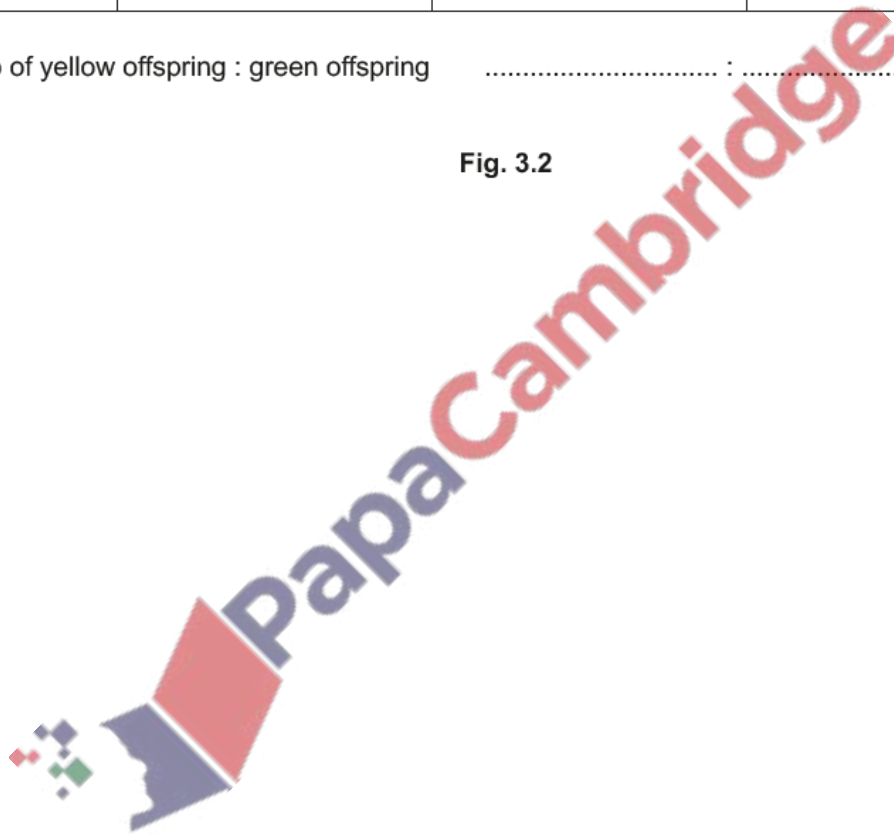

(b) Cystic fibrosis is a disease caused by a recessive allele in humans.

Fig. 3.3 is a pedigree diagram showing the inheritance of cystic fibrosis in a family.

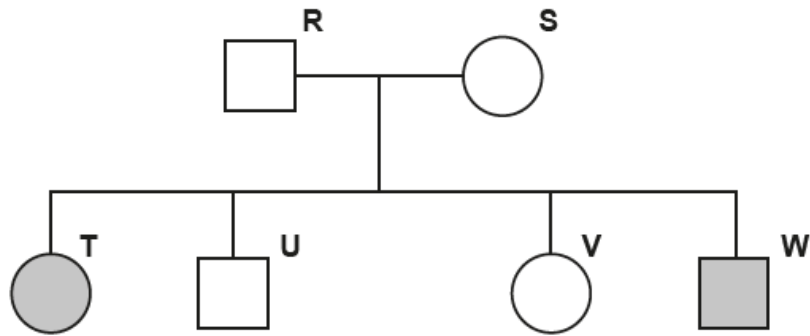

Key:





-  female without cystic fibrosis
-  female with cystic fibrosis
-  male without cystic fibrosis
-  male with cystic fibrosis

Fig. 3.3

(i) State the number of people that have cystic fibrosis.

..... [1]

(ii) Identify the letter of a person that **must** have a heterozygous genotype.

..... [1]

(iii) Person **U** has a homozygous dominant genotype.

**Circle** the probability of person **U** having a child with cystic fibrosis.

0%      25%      50%      75%      100%      [1]

[Total: 8]



(a) A class of students measured their wrist circumference, as shown in Fig. 5.1.

Wrist circumference is an example of a characteristic that shows **continuous** variation in humans.



Fig. 5.1

Fig. 5.2 shows the results of the investigation.

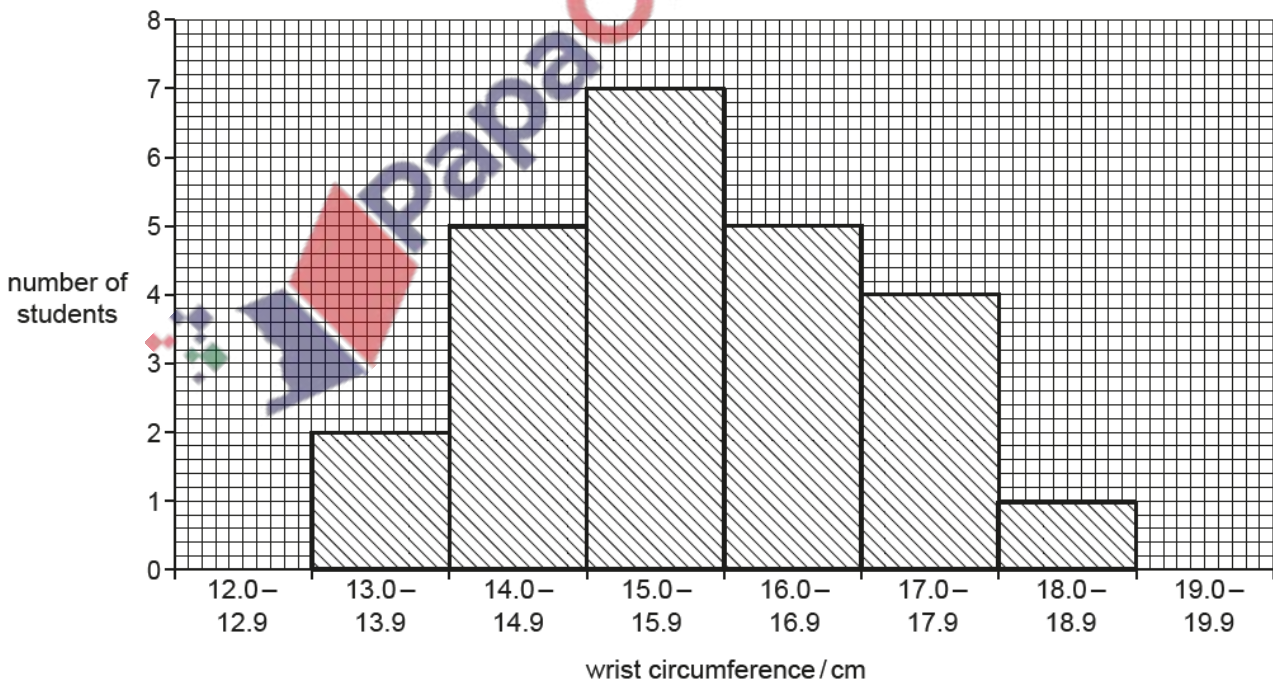

Fig. 5.2



(i) Calculate the total number of students in this investigation.

..... [1]

(ii) State the most frequent wrist circumference range.

..... [1]

(iii) Explain how these data show that wrist circumference is an example of continuous variation.

.....  
.....  
..... [1]

(b) State **one** example of discontinuous variation.

..... [1]

(c) Variation can be caused by mutation.

Complete the sentences about mutation.

A mutation is a ..... change.

Mutation is the way new ..... are formed which are versions of a gene.

Mutation can be caused by ..... radiation and some chemicals.

[3]

[Total: 7]

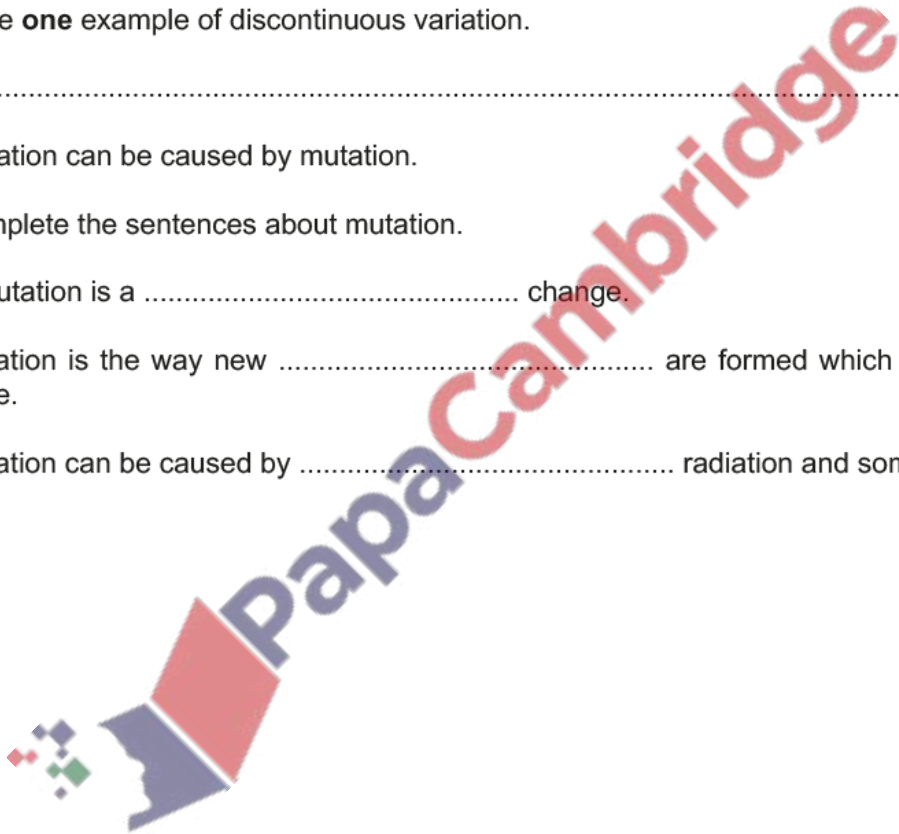

15. Nov/2021/Paper\_33/No.9  
(a) Define inheritance.

.....

.....

..... [2]

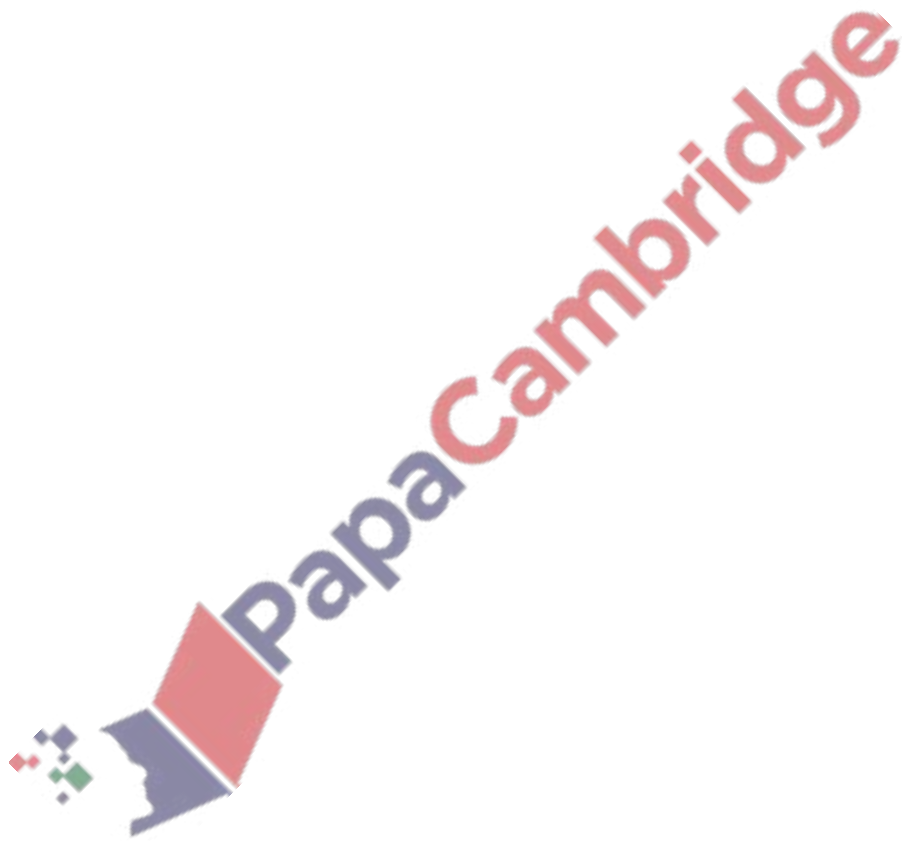

- (b) Some of the characteristics of pea plants are controlled by genes. An example of a characteristic of pea seeds is shown in Fig. 9.1. The allele for a smooth seed coat is dominant and is represented by the letter **R**. The allele for a wrinkled seed coat is recessive and is represented by the letter **r**.

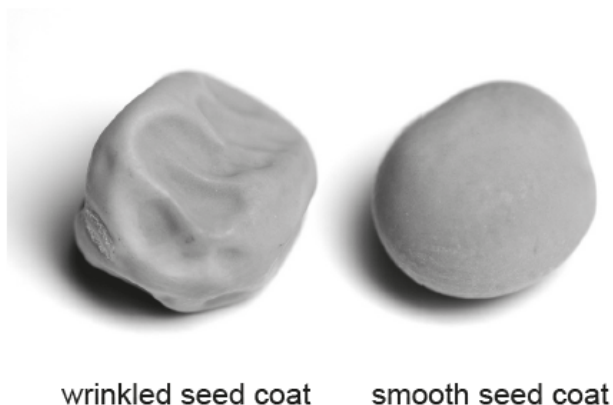

**Fig. 9.1**

The boxes on the left contain descriptions of genotypes.

The boxes on the right contain examples of the possible genotypes of the pea seeds shown in Fig. 9.1.

Draw a line to link **each** description to the correct genotype.

Draw **two** lines.

description of a genotype	genotype
heterozygous genotype	r
homozygous recessive genotype	rr
	Rr
	RR

[2]

- (c) Complete the sentence.

A gene is a length of DNA that codes for a .....

[1]

[Total: 5]

(a) Two tomato plants that produce red fruit were bred together.

This cross produced 71 offspring plants with red fruit and 26 offspring plants with yellow fruit.

Complete the genetic diagram to show this cross.

Select a suitable letter to represent the alleles and decide which allele will need a capital letter and which allele will need a lower case letter.

letter representing the allele for red fruit .....

letter representing the allele for yellow fruit .....

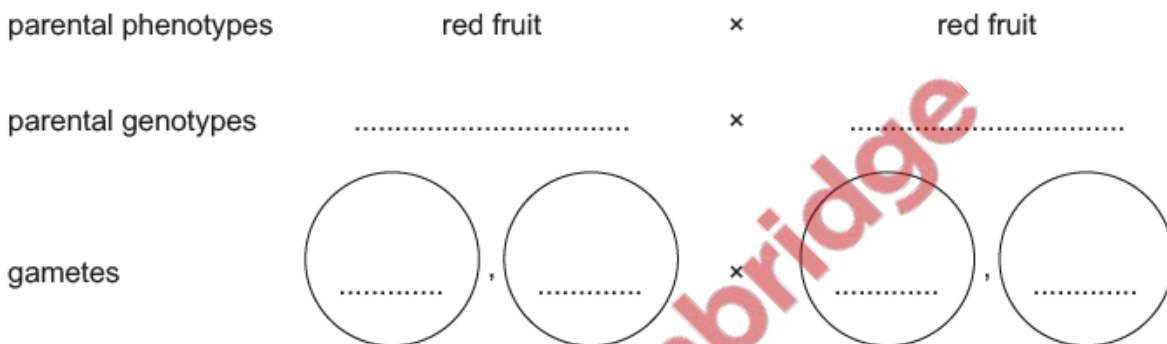

offspring genotypes .....

**expected** phenotype ratio ..... red fruit : ..... yellow fruit

**actual** phenotype ratio                      71      red fruit :      26      yellow fruit

[6]

(b) Researchers carried out some experiments on tomato plants that were homozygous for fruit colour.

State how the researchers could be sure that the fruit came from homozygous plants.

.....  
 .....  
 .....

[1]

(c) The researchers analysed two pigments, chlorophyll and lycopene, in homozygous red tomato fruit and homozygous yellow tomato fruit. Chlorophyll is found in unripe tomato fruit.

(i) Describe the function of chlorophyll.

.....  
.....  
.....  
.....  
..... [2]

(ii) State the name of **one** mineral required for the synthesis of chlorophyll.

..... [1]

(iii) The researchers analysed the concentration of the pigments in tomato fruits:

- before they were ready to eat (unripe)
- when they were ready to eat (ripe).

The results of the analysis are shown in Table 2.1.

**Table 2.1**

	chlorophyll concentration / mg per g of tomato fruit	lycopene concentration / mg per g of tomato fruit
unripe red fruit	10.0	0.0
ripe red fruit	1.2	105.7
unripe yellow fruit	6.2	0.0
ripe yellow fruit	0.4	0.7

Use the information in Table 2.1 to compare the changes in pigments in red fruit and yellow fruit as they ripen.

.....  
.....  
.....  
.....  
.....  
.....  
.....  
..... [3]

(d) A gene is responsible for the production of lycopene in fruits. Geneticists have recently produced genetically modified pink pineapples using the gene associated with the production of lycopene.

(i) Genes are found at specific locations on an important biological molecule.

State the name of this biological molecule.

..... [1]

(ii) Describe the disadvantages of genetically modifying crops.

.....  
.....  
.....  
.....  
.....  
..... [2]

[Total: 16]

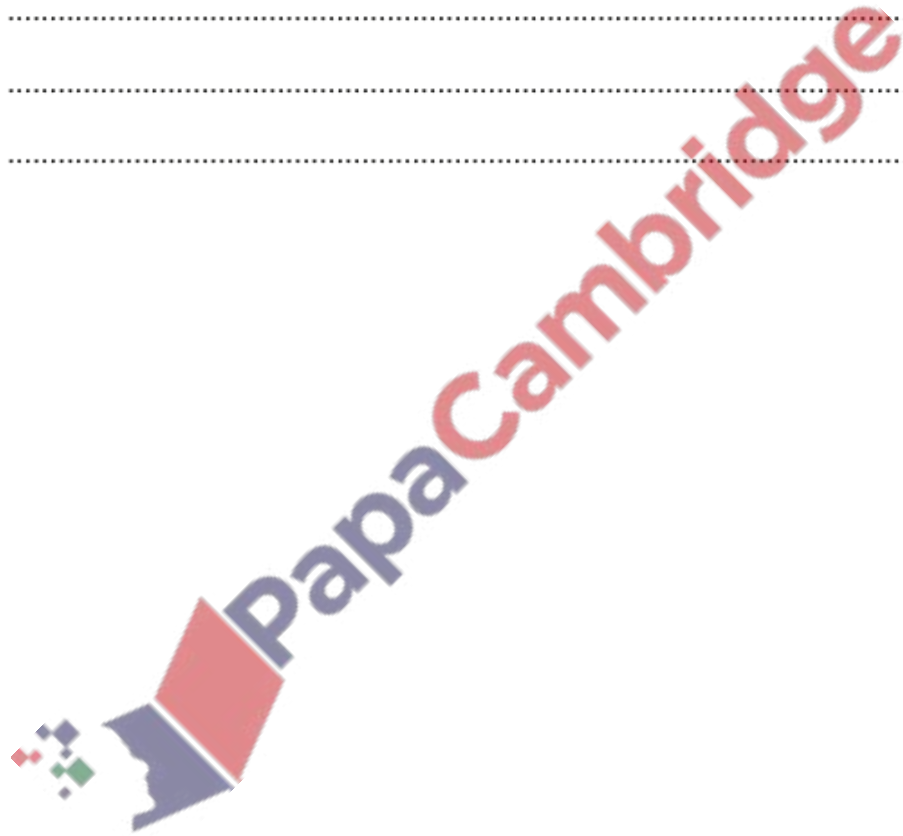

(a) A scientist investigated sexual reproduction in flowering plants.

Fig. 2.1 shows the procedure for crossing two plants of the same species.

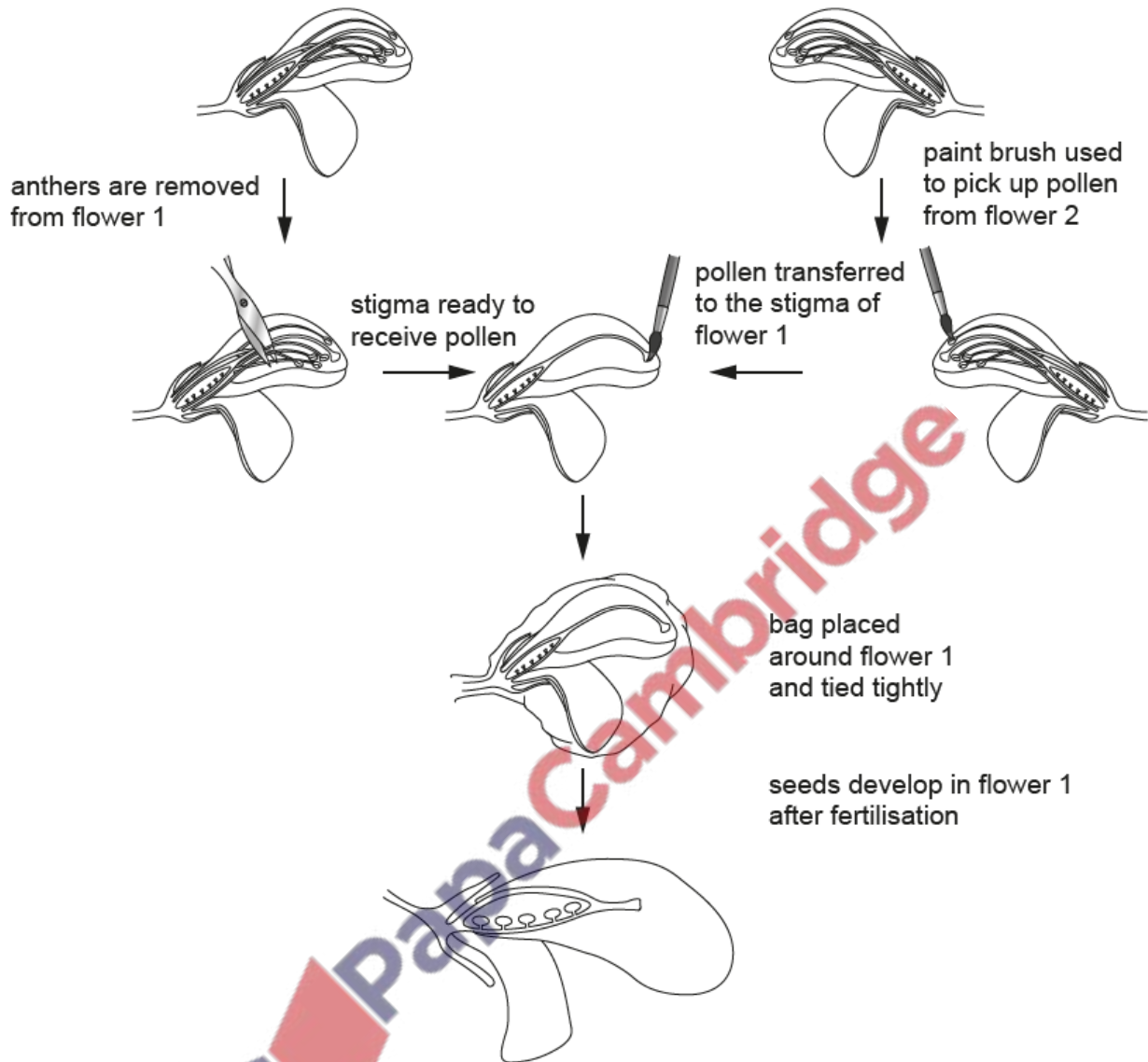

Fig. 2.1

The scientist collected the seeds and germinated them. The leaves and flowers of the offspring plants showed phenotypic variation as they were not all identical to the parent plants.

The scientist then investigated the chromosomes of all the offspring plants and found that they had exactly the same number of chromosomes as the parent plants.

(i) Define the term chromosome.

.....

.....

..... [2]



(ii) Suggest why the scientist placed a bag around flower 1.

.....  
.....  
..... [1]

(iii) Explain how sexual reproduction results in the variation that the scientist discovered in the offspring plants.

.....  
.....  
.....  
.....  
..... [2]

(iv) The chromosome number of the offspring plants is the same as the chromosome number of the parent plants in this investigation.

Explain how the chromosome number is maintained from one generation to the next.

.....  
.....  
.....  
.....  
..... [2]

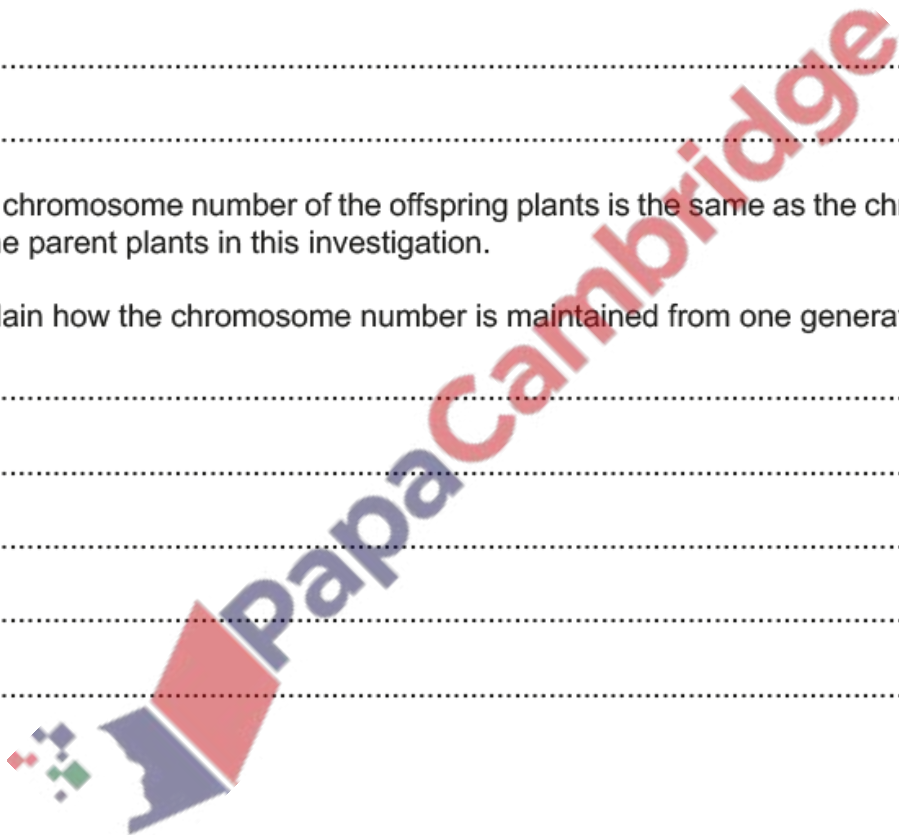

- (b) The plant *Camellia japonica* has flowers that can be white, red or a mixture of these two colours. When red-flowered plants are crossed with white-flowered plants, all the offspring plants have flowers with petals that are a mixture of red and white, as shown in Fig. 2.2.



Fig. 2.2

- The gene for petal colour in *C. japonica* is given the symbol **P**.
  - The allele for white petals is given the symbol **P<sup>W</sup>**.
  - The allele for red petals is given the symbol **P<sup>R</sup>**.
- (i) Table 2.1 shows the phenotypes of three different pairs of parent plants.

Complete Table 2.1 by giving all the possible genotypes of the offspring plants that could be produced by these parent plants.

Space for working.

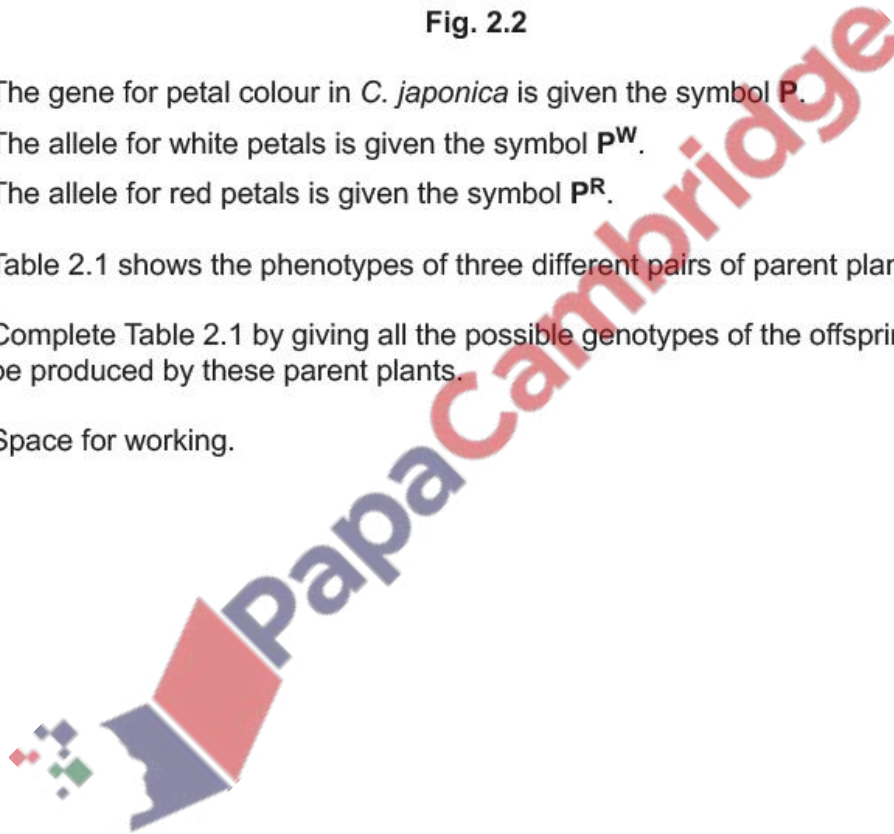

Table 2.1

phenotype of male parent	phenotype of female parent	all the possible genotypes of offspring plants produced by this cross
red petals	red petals	
white petals	red petals	
petals that are both red and white	petals that are both red and white	

[3]

(ii) State the type of inheritance that is shown by petal colour in *C. japonica*.

..... [1]

[Total: 11]

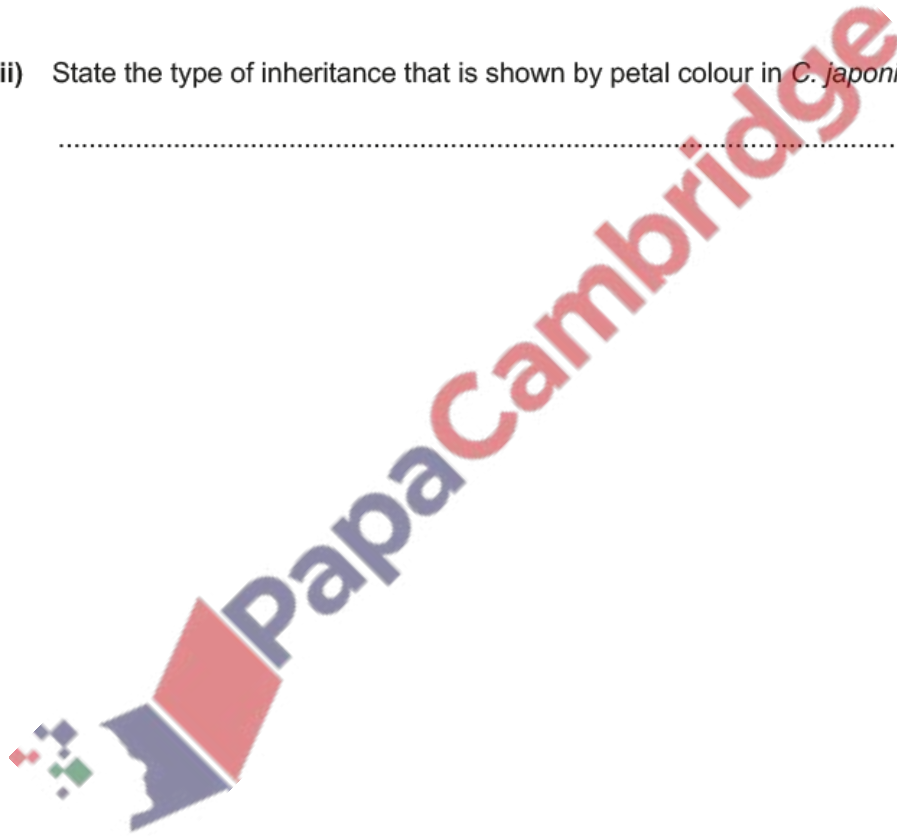

18. Nov/2021/Paper\_43/No.3

A researcher investigated genetic variation in fruit flies, *Drosophila melanogaster*.

The bodies of fruit flies can be black or yellow. A yellow body colour is a recessive feature in fruit flies.

(a) Two heterozygous fruit flies with black bodies were bred together.

Predict the phenotypes of the offspring **and** the phenotypic ratio for this cross.

..... [1]

(b) In another fruit fly breeding experiment, researchers counted 124 offspring with black bodies and 121 offspring with yellow bodies.

Draw a genetic diagram to explain the results of this cross. Use the letter **B** to represent the allele for black body colour and the letter **b** to represent the allele for yellow body colour.

parental phenotypes ..... × .....

parental genotypes ..... × .....



offspring genotypes .....

**expected** offspring phenotype ratio ..... black : ..... yellow

**actual** offspring phenotype ratio            124    black :            121    yellow

[5]

(c) The crab, *Cerberusa caeca*, lives in dark caves and has no coloured pigment.

Fig. 3.1 is a photograph of *C. caeca*.



Fig. 3.1

(i) *C. caeca* and *D. melanogaster* are both arthropods.

State **one** feature present in all arthropods but **not** present in vertebrates.

..... [1]

(ii) *C. caeca* is a crustacean and *D. melanogaster* is an insect.

State **one** morphological feature of *C. caeca* that distinguishes it as a crustacean and **not** as an insect.

..... [1]

