

*Topical*  
REVISION  
NOTES  
CHEMISTRY

IGCSE



- ✓ Comprehensive Revision Notes
- ✓ Effective Study Guide
- ✓ Periodic Table

*Topical*  
**REVISION  
NOTES**

**CHEMISTRY**

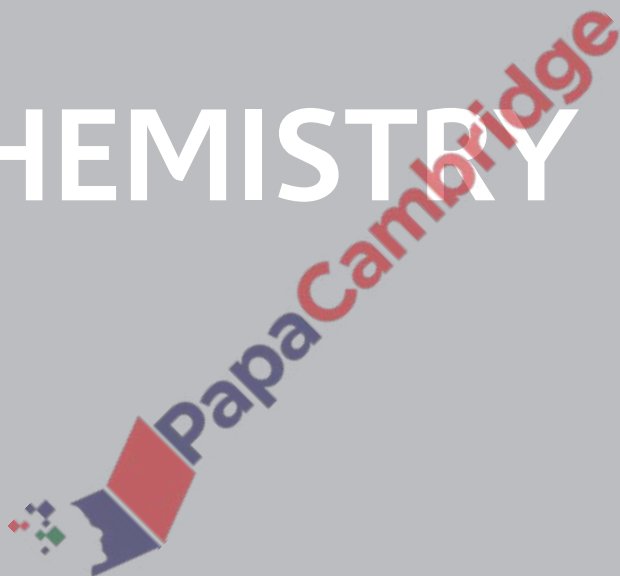

# PREFACE

**O Level Chemistry Topical Revision Notes** has been written in accordance with the latest syllabus issued by the Ministry of Education (Singapore).

This book is divided into 23 topics, each covering a topic as laid out in the syllabus. Important concepts are highlighted in each topic, with relevant examples and diagrams to help students learn how to apply theoretical knowledge.

We believe this book will be of great help to teachers teaching the subject and students preparing for their O Level Chemistry examination.

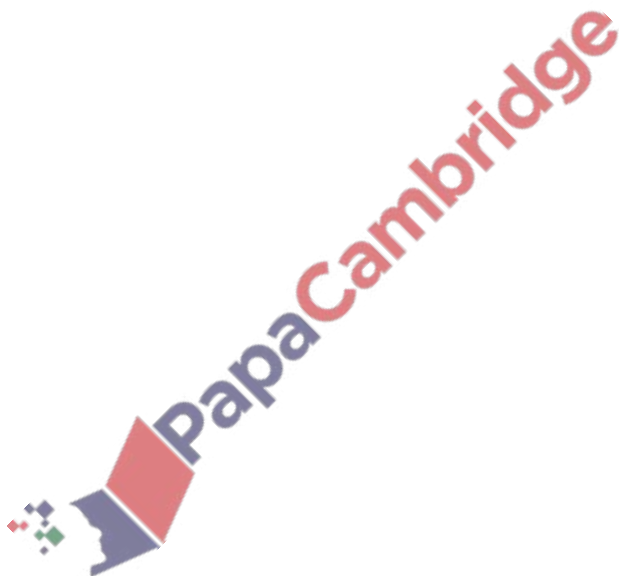

# CONTENTS

Periodic Table	v
<b>Topic 1</b> Kinetic Particle Theory	1
<b>Topic 2</b> Experimental Techniques	5
<b>Topic 3</b> Methods of Purification	7
<b>Topic 4</b> Elements and Compounds	10
<b>Topic 5</b> Atoms and Ions	11
<b>Topic 6</b> Chemical Bonding	13
<b>Topic 7</b> Structure of Matter	16
<b>Topic 8</b> Writing Formulae and Equations	19
<b>Topic 9</b> Stoichiometry and Mole Concept	20
<b>Topic 10</b> Acids and Bases	23
<b>Topic 11</b> Salts	27
<b>Topic 12</b> Oxidation and Reduction	32
<b>Topic 13</b> Metals	34
<b>Topic 14</b> Electrolysis	41
<b>Topic 15</b> Periodic Table	45
<b>Topic 16</b> Energy Changes	49
<b>Topic 17</b> Speed of Reaction	52
<b>Topic 18</b> Ammonia	55
<b>Topic 19</b> Air and Atmosphere	57
<b>Topic 20</b> Introduction to Organic Chemistry	61
<b>Topic 21</b> Alkanes and Alkenes	64
<b>Topic 22</b> Alcohols and Carboxylic Acids	67
<b>Topic 23</b> Macromolecules	70

Group												III	IV	V	VI	VII	0																																																																				
												11	12	14	16	19	20																																																																				
I	II	1 H Hydrogen 1							2 He Helium 4																																																																												
7	9	11	13	15	17	19	21	23	25	27	29	31	33	35	37	39	41	43	45	47	49	51	53	55	57	59	61	63	65	67	69	71	73	75	77	79	81	83	85	87	89	91	93	95	97	99	101	103																																					
Li Lithium 3	Be Beryllium 4	B Boron 5	C Carbon 6	N Nitrogen 7	O Oxygen 8	F Fluorine 9	Ne Neon 10	Na Sodium 11	Mg Magnesium 12	Al Aluminum 13	Si Silicon 14	P Phosphorus 15	S Sulfur 16	Cl Chlorine 17	Ar Argon 18	K Potassium 19	Ca Calcium 20	Sc Scandium 21	Ti Titanium 22	V Vanadium 23	Cr Chromium 24	Mn Manganese 25	Fe Iron 26	Co Cobalt 27	Ni Nickel 28	Cu Copper 29	Zn Zinc 30	Ga Gallium 31	Ge Germanium 32	As Arsenic 33	Se Selenium 34	Br Bromine 35	Kr Krypton 36	Rb Rubidium 37	Sr Strontium 38	Y Yttrium 39	Zr Zirconium 40	Nb Niobium 41	Mo Molybdenum 42	Tc Technetium 43	Ru Ruthenium 44	Rh Rhodium 45	Pd Palladium 46	Ag Silver 47	Cd Cadmium 48	In Indium 49	Sn Tin 50	Sb Antimony 51	Te Tellurium 52	I Iodine 53	Xe Xenon 54	Cs Caesium 55	Ba Barium 56	La Lanthanum 57	Ce Cerium 58	Pr Praseodymium 59	Nd Neodymium 60	Pm Promethium 61	Sm Samarium 62	Eu Europium 63	Gd Gadolinium 64	Tb Terbium 65	Dy Dysprosium 66	Ho Holmium 67	Er Erbium 68	Tm Thulium 69	Yb Ytterbium 70	Lu Lutetium 71	Fr Francium 87	Ra Radium 88	Ac Actinium 89	Th Thorium 90	Pa Protactinium 91	U Uranium 92	Np Neptunium 93	Pu Plutonium 94	Am Americium 95	Cm Curium 96	Bk Berkelium 97	Cf Californium 98	Es Einsteinium 99	Fm Fermium 100	Md Mendelevium 101	No Nobelium 102	Lr Lawrencium 103

a	X	b
---	---	---

a = relative atomic mass  
 X = atomic symbol  
 b = proton (atomic) number

**Key**

\*58-71 Lanthanoid series  
 †90-103 Actinoid series

# TOPIC 1

## Kinetic Particle Theory

### Objectives

Candidates should be able to:

- describe the solid, liquid and gaseous states of matter and explain their interconversion in terms of the kinetic particle theory and of the energy changes involved
- describe and explain evidence for the movement of particles in liquids and gases
- explain everyday effects of diffusion in terms of particles
- state qualitatively the effect of molecular mass on the rate of diffusion and explain the dependence of rate of diffusion on temperature

### 1. Kinetic Particle Theory

All matter is made of particles which are in constant random motion. This accounts for the properties of the three states of matter and the changes of states.

### 2. Properties of the Three States of Matter

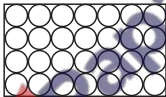
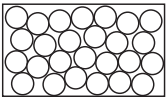
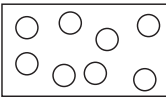
Property	Solid	Liquid	Gas
Structure			
Packing of particles	Tightly packed. Arranged in an orderly manner.	Packed closely together, but not as tightly as in solids. No regular arrangement.	Spaced far apart from each other
Movement of particles	Can only vibrate about fixed positions	Particles slide past each other	Particles move freely at high speeds
Shape	Fixed shape	No fixed shape. Takes on the shape of the container it is in.	No fixed shape. Takes on the shape of the container it is in.
Volume	Fixed volume. Not easily compressed.	Fixed volume. Not easily compressed.	No fixed volume. Easily compressed.

### 3. Changes of State

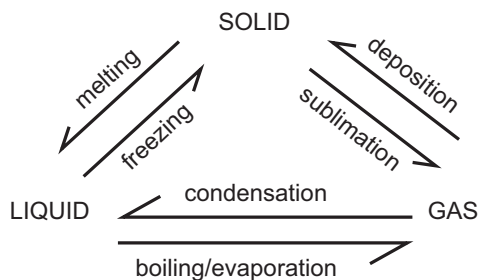

The following diagram shows the temperature change when a substance undergoes changes in state.

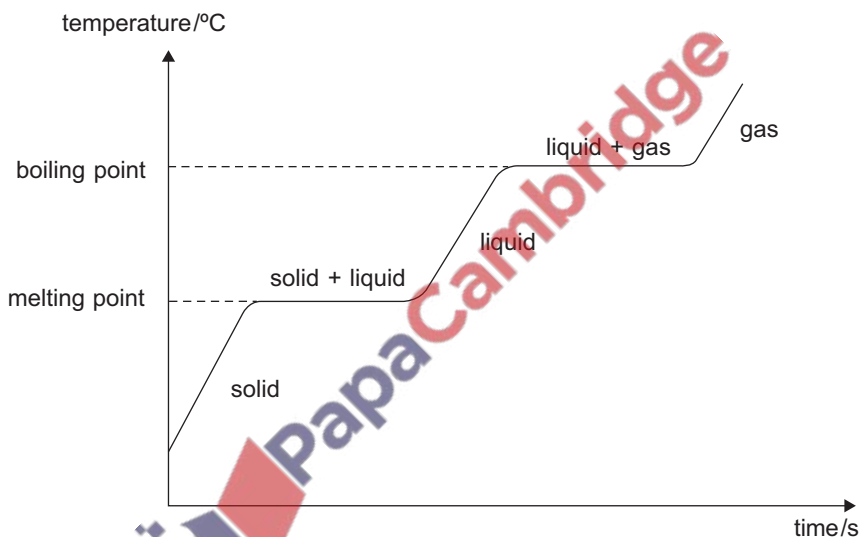

At parts where the graph rises, heat is supplied to the substance to raise its temperature. The graph becomes flat when the substance undergoes a change in state. The graph remains flat as heat is taken in to overcome the interactions between the particles.

The following diagram shows the temperature change when a pure substance undergoes cooling.

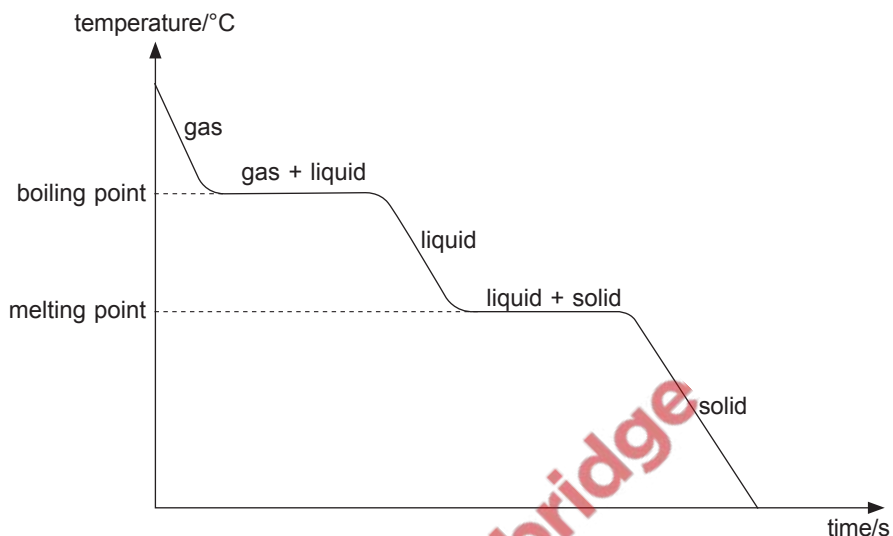

At parts where the graph falls, heat is given out from the substance to the surroundings and its temperature decreases. The graph becomes flat when the substance undergoes a change in state. The graph remains flat as the particles form bonds, producing heat which is given out to the surroundings.

1. Melting : Occurs at the melting point. Particles absorb heat and vibrate more vigorously, allowing them to overcome the interparticle interactions holding them in fixed positions.
2. Freezing : Occurs at the melting point. Particles release heat and move more slowly. Interparticle interactions are formed and the particles are forced to be held in a fixed and orderly arrangement.
3. Boiling : Occurs at the boiling point. Particles absorb heat and gain more kinetic energy. The particles move fast enough to completely overcome the forces of attraction.
4. Evaporation : Occurs below the boiling point. Particles at the surface gain sufficient energy to escape into the surroundings.
5. Condensation : Occurs at the boiling point. Particles release heat and move more slowly. The forces of attraction are then able to hold the particles closely.



#### 4. Diffusion

Particles of matter move from a region of higher concentration to a region of lower concentration.

Particles with higher mass move more slowly than particles with lower mass. For example, ammonia diffuses at a higher rate than hydrogen chloride since it is lighter ( $M_r$  of ammonia = 17,  $M_r$  of hydrogen chloride = 36.5).

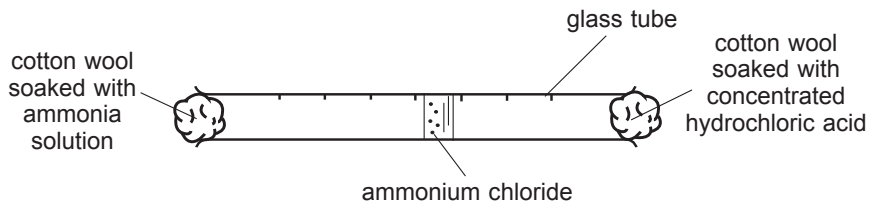

At higher temperature, the rate of diffusion is greater as the particles have more kinetic energy and can move faster.

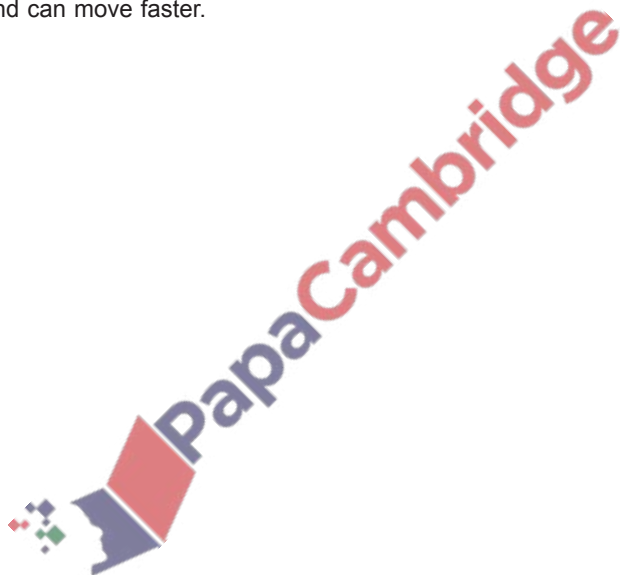

# TOPIC 2

## Experimental Techniques

### Objectives

Candidates should be able to:

- name appropriate apparatus for the measurement of time, temperature, mass and volume, including burettes, pipettes, measuring cylinders and gas syringes
- suggest suitable apparatus, given relevant information, for a variety of simple experiments, including collection of gases and measurement of rates of reaction

### 1. Measuring Volume

Volumes of solutions have to be frequently measured in chemistry experiments. The following are apparatus for measuring volume.

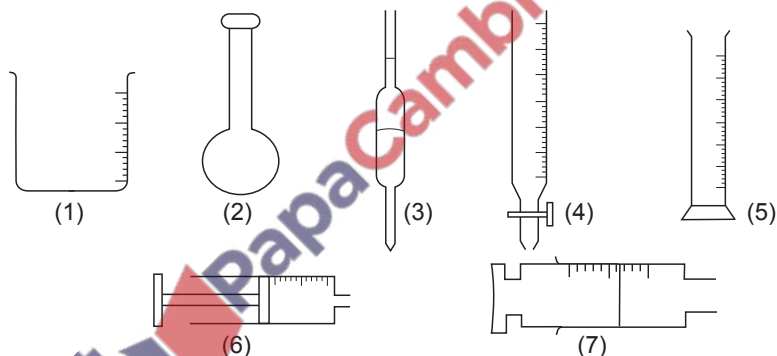

- 1. Beaker** : To measure volumes of liquids approximately according to the graduated marks on the apparatus.
- 2. Volumetric flask** : To accurately measure fixed volumes of liquids when solutions of flask particular concentrations need to be prepared.
- 3. Pipette** : To accurately measure volumes of liquids when a fixed volume of solution is needed for an experiment.
- 4. Burette** : To accurately measure (nearest  $0.1 \text{ cm}^3$ ) volumes of liquids which are used up in an experiment.
- 5. Measuring cylinder** : To measure volumes of liquids with some accuracy (nearest  $0.1 \text{ cm}^3$ ) according to the graduated marks on the apparatus.

6. Syringe : To measure small volumes of liquids with some accuracy according to the graduated marks on the apparatus.
7. Gas syringe : To accurately measure volumes of gases produced in experiments according to the graduated marks on the apparatus.

## 2. Collecting Gases Produced

1. Displacement of water: Used to collect gases which are not very soluble in water, such as oxygen and hydrogen.

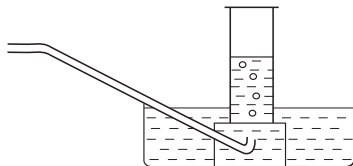

2. Downward delivery: Used to collect gases which are denser than air, such as carbon dioxide, hydrogen chloride and chlorine.



3. Upward delivery: Used to collect gases which are less dense than air, such as ammonia and hydrogen.



## 3. Drying Gases Produced

When gases produced need to be obtained dry, the moisture content has to be removed using appropriate drying agents.

1. Fused calcium chloride: This is calcium chloride which has been heated. This can be used to dry gas which does not react with calcium chloride.
2. Concentrated sulfuric acid: This is a common drying agent but it cannot be used to dry gases which are basic.
3. Quick lime: This is a drying agent used to dry basic gases such as ammonia.

# TOPIC 3

## Methods of Purification

### Objectives

Candidates should be able to:

- describe methods of separation and purification for the components of mixtures, to include:
  - use of a suitable solvent, filtration and crystallisation or evaporation
  - sublimation
  - distillation and fractional distillation
  - use of a separating funnel
  - paper chromatography
- suggest suitable separation and purification methods, given information about the substances involved in the following types of mixtures:
  - solid-solid
  - solid-liquid
  - liquid-liquid (miscible and immiscible)
- interpret paper chromatograms including comparison with 'known' samples and the use of  $R_f$  values
- explain the need to use locating agents in the chromatography of colourless compounds
- deduce from the given melting point and boiling point the identities of substances and their purity
- explain that the measurement of purity in substances used in everyday life, e.g. foodstuffs and drugs, is important

### 1. Filtration

Filtration is used to separate a mixture of a liquid (or solution) and an insoluble solid. The insoluble solid is collected as the residue while the liquid is collected as the filtrate.

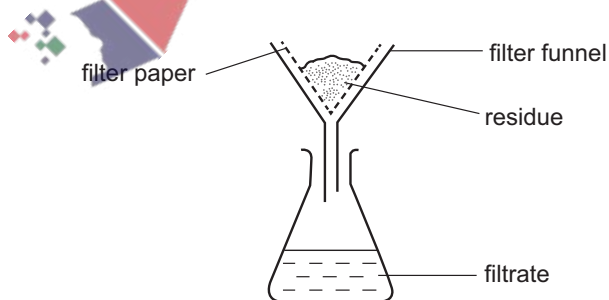

### 2. Evaporation

This method is used to evaporate off the solvent from a solution to obtain the dissolved substance. This is only applicable to substances that do not decompose upon heating.

### 3. Crystallisation

Crystallisation can be used to recover a dissolved substance from its solution. This method is particularly useful for substances that decompose upon heating. This is carried out by heating a solution until it is saturated. The saturated solution is then left to cool, allowing for the substance to crystallise.

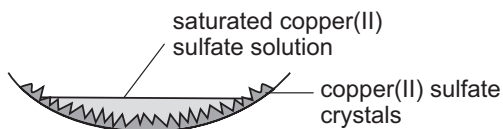

### 4. Sublimation

This method is used to obtain a solid that sublimes from a solid mixture. Examples of solids that sublime include iodine and naphthalene (found in mothballs).

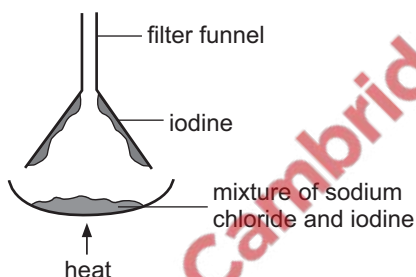

### 5. Distillation

Distillation is used to separate a liquid from a mixture. The substances in the mixture must have large differences in boiling points for the pure liquid to be obtained.

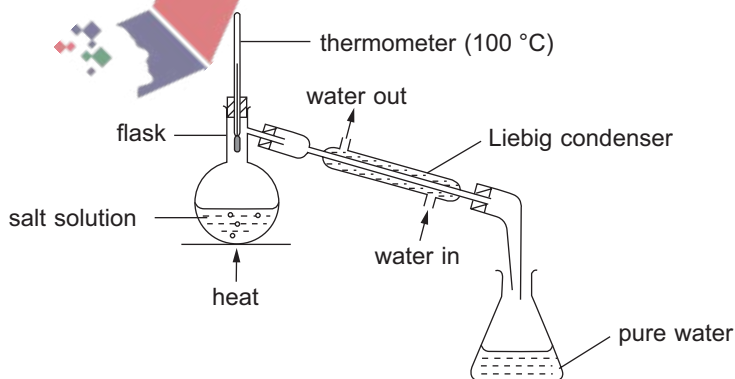

## 6. Fractional Distillation

In cases where a mixture contains liquids that have relatively close boiling points, fractional distillation is used for purification.

In such mixtures, the vapour produced is a mixture of these substances. The fractionating column aids in separating the vapour into individual components, which allow for the collection of pure substances.

## 7. Separation using a Separating Funnel

The separating funnel is used to separate a mixture of liquids that have different densities. The liquid with lower density is found in the top layer while the liquid with higher density is found in the bottom layer.

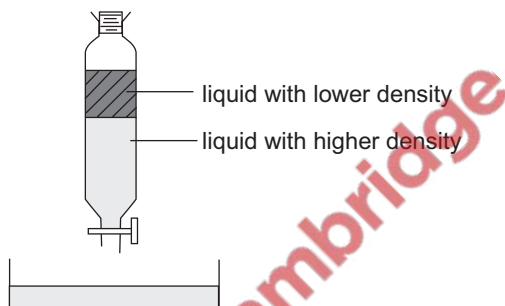

## 8. Paper Chromatography

This is used in the separation of small quantities of mixtures. The mixture is separated based on the difference in solubility of its components in a particular solvent.

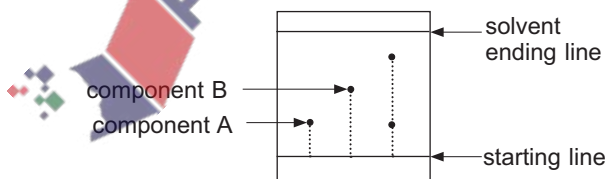

The identity of a component in the mixture can be deduced by comparing the  $R_f$  value obtained in the chromatogram with existing  $R_f$  values of known substances.

$$R_f \text{ value of a component} = \frac{\text{distance moved by component from the starting line}}{\text{distance moved by solvent from the starting line}}$$

A locating agent is used to expose colourless spots in a chromatogram.

# TOPIC 4

## Elements and Compounds

### Objectives

Candidates should be able to:

(a) describe the differences between elements, compounds and mixtures

#### 1. Elements, Compounds and Mixtures

An element is a substance that cannot be broken down into simpler substances through any chemical or physical means. Elements can exist as atoms or molecules. Each molecule of an element can consist of two or more atoms that are chemically combined.

A compound is a substance that contains two or more elements which are chemically combined in a fixed ratio. It can consist of either molecules or ions. The properties of a compound differ from its constituent elements.

A mixture consists of two or more substances that are mixed together. These substances can be elements or compounds. The ratio of these substances in a mixture is not fixed. The components in a mixture can easily be separated through physical methods.



# TOPIC 5

## Atoms and Ions

### Objectives

Candidates should be able to:

- state the relative charges and approximate relative masses of a proton, a neutron and an electron
- describe, with the aid of diagrams, the structure of an atom as containing protons and neutrons (nucleons) in the nucleus and electrons arranged in shells (energy levels)
- define *proton (atomic) number* and *nucleon (mass) number*
- interpret and use symbols such as  $^{12}_6\text{C}$
- define the term *isotopes*
- deduce the numbers of protons, neutrons and electrons in atoms and ions given proton and nucleon numbers

### 1. Subatomic Particles

Subatomic Particle	Proton	Neutron	Electron
Mass (amu)	1	1	$\frac{1}{1840}$
Charge	+1	0	-1

1 atomic mass unit (amu) is approximately  $1.67 \times 10^{-27}$  kg.

Protons and neutrons are found in the nucleus of an atom. They are collectively known as nucleons.

Electrons are found outside the nucleus. They are arranged in shells, also referred to as energy levels, which surround the nucleus.

Isotopes are atoms of the same element that have different numbers of neutrons. They share the same chemical properties but may differ in their physical properties.



## 2. Chemical Symbol



Each element is represented by a unique chemical symbol.

The nucleon number, or the mass number, gives the total number of protons and neutrons in the nucleus of an atom.

The proton number, also called the atomic number, gives the number of protons in the nucleus of an atom. The number of electrons is equal to the number of protons in an atom.

## 3. Electronic Structure

Electrons are arranged in shells around the nucleus of an atom. The first shell can contain up to 2 electrons and the second shell can hold up to 8 electrons. For simple analysis, it is taken that the third shell holds a maximum of 8 electrons.

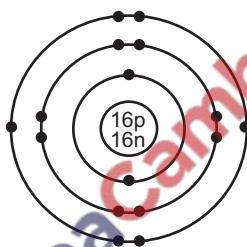

Structure of a sulfur atom

Sulfur is represented by the symbol  ${}_{16}^{32}\text{S}$ , indicating that it has 16 protons and 16 neutrons. The number of neutrons is calculated by subtracting the atomic number from the nucleon number. Since it is electrically neutral, it has 16 electrons as well.

The first electron shell contains 2 electrons, the second shell contains 8 electrons and the third shell contains 6 electrons. The electronic configuration can be written as 2.8.6.

The outermost electron shell is also called the valence electron shell.

# TOPIC 6

## Chemical Bonding

### Objectives

#### Candidates should be able to:

- describe the formation of ions by electron loss/gain in order to obtain the electronic configuration of a noble gas
- describe the formation of ionic bonds between metals and non-metals
- state that ionic materials contain a giant lattice in which the ions are held by electrostatic attraction
- deduce the formulae of other ionic compounds from diagrams of their lattice structures, limited to binary compounds
- relate the physical properties (including electrical property) of ionic compounds to their lattice structure
- describe the formation of a covalent bond by the sharing of a pair of electrons in order to gain the electronic configuration of a noble gas
- describe, using 'dot-and-cross' diagrams, the formation of covalent bonds between non-metallic elements
- deduce the arrangement of electrons in other covalent molecules
- relate the physical properties (including electrical property) of covalent substances to their structure and bonding

#### 1. Formation of Ions

An atom is most stable when the valence electron shell is completely filled. Atoms of elements either gain or lose electrons to attain a stable electronic configuration.

Non-metals usually gain electrons to form negative ions (anions) while metals usually lose electrons to form positive ions (cations).

The charge of an ion can be found by finding the difference between the number of electrons and the number of protons.

## 2. Ionic Bonding

This type of bonding takes place between oppositely-charged ions. This usually occurs for compounds made from a metal and a non-metal.

Ionic bonds are formed by electron transfer, where metal atoms donate electrons to non-metal atoms. The ions are arranged in an ionic lattice and are held together by electrostatic forces of attraction.

Two examples of dot-and-cross diagrams that illustrate the formation of ionic bonds are as shown.

1. Sodium (metal) reacts with chlorine (non-metal) to form sodium chloride,  $\text{NaCl}$

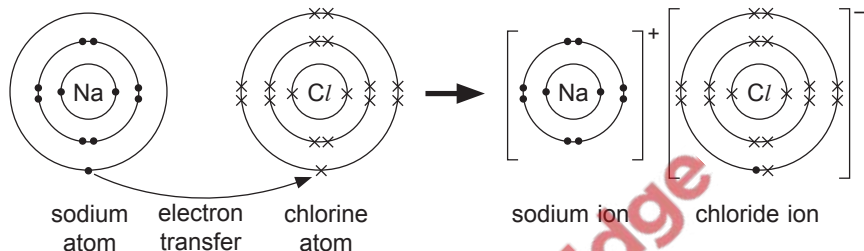

2. Magnesium (metal) reacts with chlorine (non-metal) to form magnesium chloride,  $\text{MgCl}_2$

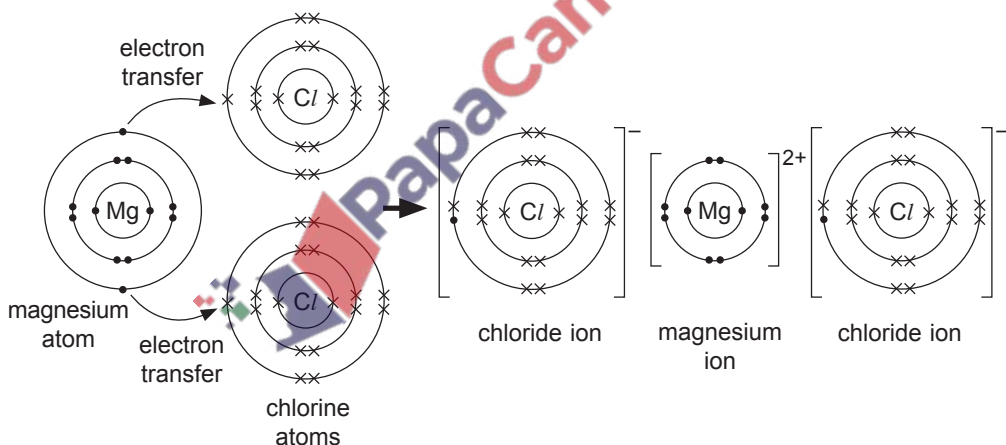

### 3. Covalent Bonding

Covalent bonds are formed between non-metal atoms. The bond is formed by sharing of electrons between atoms.

A single covalent bond is formed by the sharing of two electrons between two atoms, with the atoms contributing one electron each.

Covalent substances can be found as simple molecules or as large molecules.

Some of the common covalent compounds are shown below with their electron sharing arrangements. Note that only the outermost electrons are used for electron sharing.

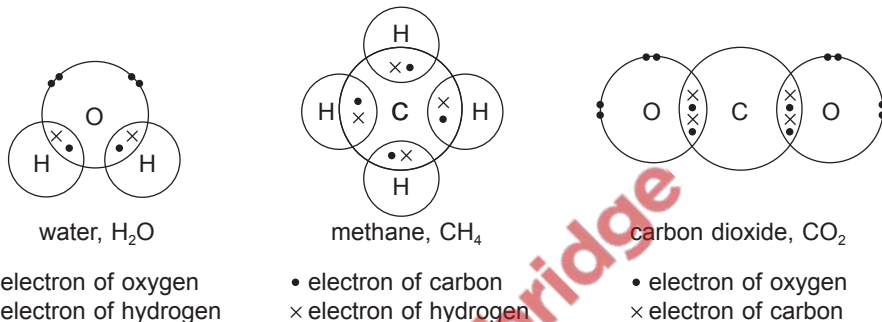

Covalent bonds are also formed between atoms of the same elements. Hydrogen, oxygen, nitrogen and halogen (Group VII) elements exist as diatomic molecules by forming covalent molecules of two atoms bonded together. The covalent bonds in hydrogen and oxygen molecules are shown below.

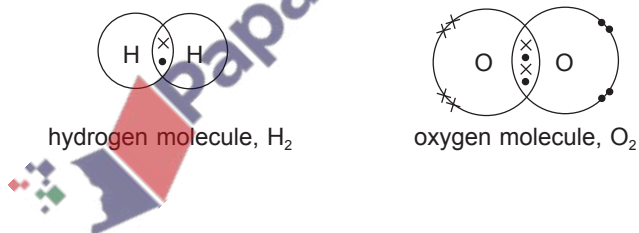

Objectives

Candidates should be able to:

- compare the structure of simple molecular substances, e.g. methane; iodine, with those of giant molecular substances, e.g. poly(ethene); sand (silicon dioxide); diamond; graphite in order to deduce their properties
- compare the bonding and structures of diamond and graphite in order to deduce their properties such as electrical conductivity, lubricating or cutting action
- deduce the physical and chemical properties of substances from their structures and bonding and vice versa
- describe metals as a lattice of positive ions in a 'sea of electrons'
- relate the electrical conductivity of metals to the mobility of the electrons in the structure

1. Ionic Compounds

In ionic compounds, the positive ions and negative ions are held together by strong electrostatic forces of attraction, forming giant lattice structures.

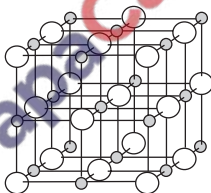

Ionic compounds have very high melting and boiling points. This is because a lot of energy is required to overcome the strong forces of attraction holding the ions in the lattice together before the compound can melt or boil. Due to their high melting and boiling points, they are usually found as solids at room temperature and pressure.

The melting and boiling points are influenced by the strength of the electrostatic forces of attraction. Magnesium oxide has a higher melting point than sodium chloride. The ions in sodium chloride have charges of +1 and -1, while the ions in magnesium oxide have charges of +2 and -2. The electrostatic forces of attraction are stronger in magnesium oxide, hence more energy is required to melt it.

Ionic compounds conduct electricity when dissolved in water or in molten state, but not when in solid state. In aqueous and molten states, the ions are free to move and hence can conduct electricity. In solid state however, the ions are held in fixed positions in the lattice structure.

## 2. Simple Molecular Structures

Covalent substances with simple molecular structures consist of small discrete molecules that are held together by weak intermolecular forces of attraction. These forces are also known as van der Waals' force of attraction.

Substances with simple molecular structures have low melting and boiling points as a small amount of energy is required to overcome the weak intermolecular forces of attraction.

The strength of the forces of attraction is dependent on molecular size. Substances with large molecules are held together by stronger intermolecular forces compared to those with small molecules. Therefore, the melting and boiling points of large simple molecules are higher than those of small simple molecules.

These substances do not conduct electricity as they do not have any freely-moving charge carriers.

## 3. Giant Molecular Structures

Covalent substances with giant molecular structures consist of an extensive network of atoms held together by covalent bonds.

Substances with giant molecular structures have high melting and boiling points as a lot of energy is required to overcome the strong covalent bonds holding the atoms together.

Apart from graphite, giant molecular substances usually do not conduct electricity.

## 4. Diamond and Graphite

Diamond and graphite are allotropes of carbon which have giant molecular structures. The carbon atoms in these substances are arranged in different manners, hence giving them different properties.

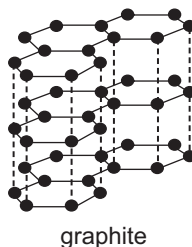
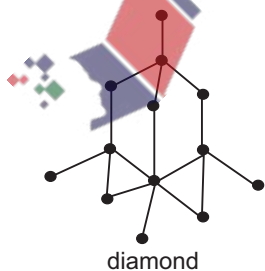

Each atom in diamond is covalently bonded to four other atoms. Due to its rigid structure, diamond is a very hard substance and is used for drill tips or cutting tools.

All valence electrons in each carbon atom are used for covalent bonding, therefore diamond cannot conduct electricity.

Each atom in graphite is covalently bonded to three other atoms, forming a continuous layer of carbon atoms arranged in hexagons. Graphite consists of many layers of carbon atoms which are held together by weak van der Waals' forces of attraction. These layers of carbon atoms can slide past each other, making graphite a soft and slippery substance. This makes graphite suitable for use as a lubricant.

Each carbon atom in graphite has one free electron since each atom forms only three covalent bonds. These electrons are delocalised along the layer of carbon atoms. The presence of delocalised electrons allows for the conduction of electricity.

Both diamond and graphite have very high melting and boiling points as a lot of energy is required to break the strong covalent bonds holding the carbon atoms together.

## 5. Metallic Bonding

Atoms in a metal are held by metallic bonding in a giant lattice structure. These atoms lose their valence electrons, which are then delocalised across the metal lattice. The metal lattice structure consists of lattice of positive ions surrounded by a 'sea of electrons'. The electrostatic forces of attraction between the positive ions and the mobile electrons hold the structure together.

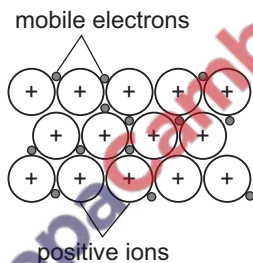

Metals are good conductors of electricity and heat due to the presence of mobile electrons.

Metals have high melting and boiling points as a lot of energy is required to overcome the strong electrostatic forces of attraction between the 'sea of electrons' and the lattice of positive ions.

As atoms in metals are packed tightly in layers, they usually have high densities. The neat arrangement of atoms also makes metals malleable and ductile, which means that metals can be shaped by applying pressure and stretched without breaking. Metallic bonding is not affected when a force is applied as the layers of positive ions can slide past each other among the 'sea of mobile electrons'.

# TOPIC 8

## Writing Formulae and Equations

### Objectives

Candidates should be able to:

- state the symbols of the elements and formulae of the compounds mentioned in the syllabus
- deduce the formulae of simple compounds from the relative numbers of atoms present and vice versa
- deduce the formulae of ionic compounds from the charges on the ions present and vice versa
- interpret chemical equations with state symbols
- construct chemical equations, with state symbols, including ionic equations

### 1. Chemical Equations

A chemical equation shows the reactants and products in a reaction and may include state symbols, which show the physical states of each substance.

Solid, liquid and gaseous states are represented by the state symbols (s), (l) and (g) respectively. Substances that are dissolved in water to form an aqueous solution are represented with the state symbol (aq).

As atoms cannot be created or destroyed, the number of atoms of each element has to be the same on both sides of the equation, i.e. the equation has to be balanced. Numbers are added in front of the chemical formulae to balance the equation.

A reaction may be described as 'irreversible' or 'reversible'. This can be indicated in a chemical equation by using different arrows.  $\rightarrow$  is used for irreversible reactions and  $\rightleftharpoons$  is used for reversible reactions.

### 2. Ionic Equations

Ionic equations are chemical equations that show the reaction involving ions. It is important to note the physical states of all substances in the reaction.

A balanced chemical equation with state symbols is first written. Break this equation down further by writing the dissolved substances in terms of ions. It is useful to note the solubility rules of salts in water before rewriting the equation. The ionic equation is then obtained by cancelling out spectator ions.

Spectator ions remain unchanged at the end of the reaction, showing that they do not take part in the reaction.



# TOPIC 9

## Stoichiometry and Mole Concept

### Objectives

Candidates should be able to:

- define relative atomic mass,  $A_r$ ,
- define relative molecular mass,  $M_r$ , and calculate relative molecular mass (and relative formula mass) as the sum of relative atomic masses
- calculate the percentage mass of an element in a compound when given appropriate information
- calculate empirical and molecular formulae from relevant data
- calculate stoichiometric reacting masses and volumes of gases (one mole of gas occupies  $24 \text{ dm}^3$  at room temperature and pressure); calculations involving the idea of limiting reactants may be set
- apply the concept of solution concentration (in  $\text{mol/dm}^3$  or  $\text{g/dm}^3$ ) to process the results of volumetric experiments and to solve simple problems
- calculate % yield and % purity

#### 1. Relative Atomic Mass

The relative atomic mass ( $A_r$ ) of an atom is the average mass of the atom compared with  $\frac{1}{12}$  of the mass of a carbon-12 atom. This value is a ratio and does not have any units.

The relative atomic mass is not always a whole number due to the presence of isotopes (as covered in Topic 5). This value is obtained by taking the average of the relative masses of isotopes of an element based on their natural abundance.

#### 2. Relative Molecular Mass and Relative Formula Mass

The mass of a molecule, which can be a compound or an element, is given by the relative molecular mass ( $M_r$ ). The relative molecular mass is the average mass of the molecule compared with  $\frac{1}{12}$  of the mass of a carbon-12 atom.

This value is the sum of the relative atomic masses of the component atoms as stated in the chemical formula of the molecule.

Ionic compounds do not exist as molecules, therefore it is more accurate to refer to their mass as the relative formula mass. The relative formula mass of an ionic compound is the sum of the relative atomic masses of atoms as stated in its chemical formula.

### 3. The Mole

1 mole of any substance consists of  $6 \times 10^{23}$  particles. The number  $6 \times 10^{23}$  is called the Avogadro's constant.

The number of moles of a substance can be obtained by dividing the total number of particles by the Avogadro's constant.

$$\text{Number of moles} = \frac{\text{Number of particles}}{6 \times 10^{23}}$$

The mass of 1 mole of substance is given by its molar mass. The molar mass of an element is equal to its relative atomic mass. For a molecular substance, its molar mass is equal to its relative molecular mass. Likewise, the molar mass of an ionic compound is equal to its relative formula mass.

Molar mass has the units g/mol. The number of moles can be obtained by dividing the mass of the substance in grams by its molar mass.

$$\text{Number of moles} = \frac{\text{Mass (g)}}{\text{Molar mass (g/mol)}}$$

### 4. Percentage Composition of Compounds

The percentage by mass of an element in a compound is given by the following formula.

Percentage by mass of an element in a compound

$$= \frac{\text{Number of atoms of the element} \times A_r \text{ of the element}}{\text{Molar mass (g/mol)}} \times 100\%$$

### 5. Empirical and Molecular Formulae

The empirical formula of a compound gives the simplest ratio of the number of atoms of each element in the compound. This is found by taking the proportions of atoms of each element and comparing them in terms of moles.

The molecular formula of a compound gives the actual number of atoms of each element in the compound. The molecular formula of a compound is always a multiple of its empirical formula.

Since the molecular formula is always a multiple of the empirical formula, a compound with the empirical formula  $A_xB_y$  has a molecular formula of  $(A_xB_y)_n$ , where  $n$  is an integer. The value of  $n$  can be found using the following formula.

$$n = \frac{\text{actual relative molecular mass}}{\text{relative molecular mass from empirical formula}}$$

## 6. Calculations Involving Gases

1 mole of any gas occupies a volume of  $24 \text{ dm}^3$  at room temperature and pressure. This volume is also called the molar volume. Recall that  $1 \text{ dm}^3$  is equal to  $1000 \text{ cm}^3$ .

The number of moles of gas is given by dividing the volume of the gas by the molar volume. Note that the calculation applies only at room temperature and pressure.

$$\text{Number of moles} = \frac{\text{Volume of gas (dm}^3\text{)}}{24 \text{ dm}^3}$$

## 7. Calculations Involving Solutions

Calculating the amount of reactant particles in a solution requires the concentration of the solution. The concentration gives the amount of reactants dissolved per unit volume of a solution. This can be expressed in  $\text{g/dm}^3$  or  $\text{mol/dm}^3$ .

Concentration in  $\text{g/dm}^3$  can be converted to  $\text{mol/dm}^3$  by using the formula below.

$$\text{Concentration in mol/dm}^3 = \frac{\text{Concentration in g/dm}^3}{\text{Molar mass of reactant in g/mol}}$$

## 8. Percentage Yield and Percentage Purity

The percentage yield of a reaction is calculated using the theoretical yield and the actual yield.

$$\text{Percentage yield} = \frac{\text{Actual yield}}{\text{Theoretical yield}} \times 100\%$$

The theoretical yield refers to the calculated amount of products, assuming that the reaction goes into completion. The actual yield is the amount of product that forms in the actual reaction.

The percentage purity gives the percentage of a substance in an impure sample.

$$\text{Percentage purity} = \frac{\text{Mass of pure substance in the sample}}{\text{Mass of the sample}} \times 100\%$$

Objectives

Candidates should be able to:

- describe the meanings of the terms *acid* and *alkali* in terms of the ions they produce in aqueous solution and their effects on Universal Indicator
- describe how to test hydrogen ion concentration and hence relative acidity using Universal Indicator and the pH scale
- describe qualitatively the difference between strong and weak acids in terms of the extent of ionisation
- describe the characteristic properties of acids as in reactions with metals, bases and carbonates
- state the uses of sulfuric acid in the manufacture of detergents and fertilisers; and as a battery acid
- describe the reaction between hydrogen ions and hydroxide ions to produce water,  $\text{H}^+ + \text{OH}^- \rightarrow \text{H}_2\text{O}$ , as neutralisation
- describe the importance of controlling the pH in soils and how excess acidity can be treated using calcium hydroxide
- describe the characteristic properties of bases in reactions with acids and with ammonium salts
- classify oxides as acidic, basic, amphoteric or neutral based on metallic/non-metallic character

1. Physical Properties of Acids

An acid is a substance that dissolves in water to produce hydrogen ions ( $\text{H}^+$ ). Acids have a sour taste, turn blue litmus red and give solutions with pH values below 7.

As hydrogen ions are responsible for the properties of acids, an acid that is not dissolved in water does not show these properties.

Some commonly used acids are hydrochloric acid ( $\text{HCl}$ ), sulfuric acid ( $\text{H}_2\text{SO}_4$ ) and nitric acid ( $\text{HNO}_3$ ).

2. Chemical Properties of Acids

Dilute acids react with metals that lie above hydrogen in the reactivity series. The reaction produces salt and hydrogen gas.

zinc + dilute hydrochloric acid  $\rightarrow$  zinc chloride + hydrogen



Metals such as copper and silver do not react with dilute acids as they are unreactive.

Although lead lies above hydrogen in the reactivity series, it appears to be unreactive in dilute hydrochloric acid and dilute sulfuric acid. This is due to the formation of a layer of insoluble salt around the metal. The layer prevents contact between the acid and the metal, therefore causing the reaction to end prematurely.

Acids react with carbonates (and hydrogen carbonates) to produce salt, water and carbon dioxide.

calcium carbonate + dilute sulfuric acid → calcium sulfate + water + carbon dioxide  
 $\text{CaCO}_3(\text{s}) + \text{H}_2\text{SO}_4(\text{aq}) \rightarrow \text{CaSO}_4(\text{aq}) + \text{H}_2\text{O}(\text{l}) + \text{CO}_2(\text{g})$

Acids react with bases to form salt and water. The base could be a metal oxide or an alkali.

aluminium oxide + dilute hydrochloric acid → aluminium chloride + water  
 $\text{Al}_2\text{O}_3(\text{s}) + 6\text{HCl}(\text{aq}) \rightarrow 2\text{AlCl}_3(\text{aq}) + 3\text{H}_2\text{O}(\text{l})$

sodium hydroxide + dilute hydrochloric acid → sodium chloride + water  
 $\text{NaOH}(\text{aq}) + \text{HCl}(\text{aq}) \rightarrow \text{NaCl}(\text{aq}) + \text{H}_2\text{O}(\text{l})$

### 3. Acid Strength and Concentration

Acid strength is determined by the degree of ionisation of an acid in water.

A strong acid fully ionises in water to form  $\text{H}^+$  ions. Such acids include hydrochloric acid, sulfuric acid and phosphoric acid.

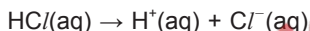

A weak acid partially ionises in water. The partial dissociation is represented in an equation with a  $\rightleftharpoons$  symbol. Examples of weak acids include carboxylic acids, such as ethanoic acid ( $\text{CH}_3\text{COOH}$ ).



The concentration of an acid depends on the amount of acid dissolved in water. Dissolving a small amount of acid in water gives a dilute acid solution, while dissolving a large amount of acid in water gives a concentrated acid solution.

### 4. Uses of Sulfuric Acid

Sulfuric acid ( $\text{H}_2\text{SO}_4$ ) is an important substance in the chemical industries. It is used in the manufacture of detergents and fertilisers. It is also used in car batteries as an electrolyte.

### 5. Physical Properties of Bases

A base is a metal oxide or hydroxide that reacts with acids to produce salt and water.

Some bases dissolve in water to produce  $\text{OH}^-$  ions. These bases are known as alkalis. Examples of such alkalis include sodium hydroxide and calcium hydroxide.

Bases have a bitter taste, turn red litmus blue, and give solutions with pH values above 7.

## 6. Chemical Properties of Bases

Alkalis undergo neutralisation with acids to produce salt and water only. Neutralisation involves the reaction between  $\text{H}^+$  and  $\text{OH}^-$  ions to produce water. This can be described in the following ionic equation.

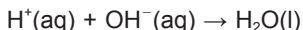

Heating alkalis with ammonium salts produces salt, water and ammonia gas.

sodium hydroxide + ammonium chloride  $\rightarrow$  sodium chloride + water + ammonia



## 7. The pH Scale

The pH scale is a measure of acidity or basicity of substances that are dissolved in water. This measurement is made based on the relative concentrations of  $\text{H}^+$  and  $\text{OH}^-$  ions present.

The pH scale ranges from 0 to 14. Acids have pH values below 7 while bases have pH values above 7. Neutral solutions have a pH value of 7.

Acids have higher concentrations of  $\text{H}^+$  ions compared to  $\text{OH}^-$  ions. An acid that has a high concentration of  $\text{H}^+$  ions will have a lower pH value than an acid with a low concentration of  $\text{H}^+$  ions.

Bases have higher concentrations of  $\text{OH}^-$  ions compared to  $\text{H}^+$  ions. A base that has a high concentration of  $\text{OH}^-$  ions will have a higher pH value than a base with a low concentration of  $\text{OH}^-$  ions.

## 8. pH Indicators

A pH indicator displays different colours at different pH values.

Universal Indicator is a mixture of pH indicators that gives different colours at different pH values. The table below lists the different colours and the pH range at which they are observed.

pH range	Colour
Below 3	Red
3 to 6	Orange/Yellow
7	Green
8 to 11	Blue
Above 11	Violet

## 9. Oxides

Oxides are compounds formed from oxygen and another element. These can be categorised into four types of oxides, namely acidic oxides, basic oxides, amphoteric oxides and neutral oxides.

Non-metals usually form acidic oxides. These oxides can dissolve in water to give acids. Acidic oxides react with bases to form salt and water. For example, carbon dioxide reacts with calcium hydroxide to form calcium carbonate and water.

carbon dioxide + calcium hydroxide → calcium carbonate + water  
 $\text{CO}_2(\text{g}) + \text{Ca}(\text{OH})_2(\text{aq}) \rightarrow \text{CaCO}_3(\text{s}) + \text{H}_2\text{O}(\text{l})$

Metals usually form basic oxides. Some of these oxides dissolve in water to give alkalis. Basic oxides react with acid to form salt and water. For example, magnesium oxide reacts with sulfuric acid to form magnesium sulfate and water.

magnesium oxide + sulfuric acid → magnesium sulfate + water  
 $\text{MgO}(\text{s}) + \text{H}_2\text{SO}_4(\text{aq}) \rightarrow \text{MgSO}_4(\text{aq}) + \text{H}_2\text{O}(\text{l})$

Some metals form amphoteric oxides. These oxides display both acidic and basic properties and as such, can react with both acids and bases. Such oxides include aluminium oxide ( $\text{Al}_2\text{O}_3$ ), zinc oxide ( $\text{ZnO}$ ) and lead(II) oxide ( $\text{PbO}$ ).

Some non-metals form neutral oxides, which exhibit neither basic nor acidic properties. Instances of such oxides are water ( $\text{H}_2\text{O}$ ), carbon monoxide ( $\text{CO}$ ) and nitric oxide ( $\text{NO}$ ).

## 10. Soil pH

Plants are sensitive to changes in soil pH. The pH levels can be controlled by adding certain chemicals. For acidic soil, bases such as calcium oxide (quicklime) and calcium hydroxide (slaked lime) can be added to neutralise the excess  $\text{H}^+$  ions. This process is known as 'liming'.

As some of these bases are soluble in water, care must be taken to avoid adding excess base as this would increase the soil pH. This would make the soil too alkaline for plant growth.

# TOPIC 11

## Salts

### Objectives

#### Candidates should be able to:

- describe the techniques used in the preparation, separation and purification of salts as examples of some of the techniques specified in Topic 3
- describe the general rules of solubility for common salts to include nitrates, chlorides (including silver and lead), sulfates (including barium, calcium and lead), carbonates, hydroxides, Group I cations and ammonium salts
- suggest a method of preparing a given salt from suitable starting materials, given appropriate information
- describe the use of aqueous sodium hydroxide and aqueous ammonia to identify the following aqueous cations: aluminium, ammonium, calcium, copper(II), iron(II), iron(III), lead(II) and zinc (formulae of complex ions are not required)
- describe tests to identify the following anions: carbonate (by the addition of dilute acid and subsequent use of limewater); chloride (by reaction of an aqueous solution with nitric acid and aqueous silver nitrate); iodide (by reaction of an aqueous solution with nitric acid and aqueous silver nitrate); nitrate (by reduction with aluminium in aqueous sodium hydroxide to ammonia and subsequent use of litmus paper) and sulfate (by reaction of an aqueous solution with nitric acid and aqueous barium nitrate)
- describe tests to identify the following gases: ammonia (using damp red litmus paper); carbon dioxide (using limewater); chlorine (using damp litmus paper); hydrogen (using a burning splint); oxygen (using a glowing splint) and sulfur dioxide (using acidified potassium manganate(VII))

#### 1. Solubility of Salts

While salts are ionic compounds, not all salts are soluble in water. The solubility of a salt has to be considered before deciding on the method of its preparation.

The following table summarises the solubilities of various common salts at room temperature.

Soluble salts	Insoluble salts
All nitrates	–
All halides ( $\text{Cl}^-$ , $\text{Br}^-$ , $\text{I}^-$ ) except	Silver halides ( $\text{AgCl}$ , $\text{AgBr}$ , $\text{AgI}$ ) and lead(II) halides ( $\text{PbCl}_2$ , $\text{PbBr}_2$ , $\text{PbI}_2$ )
All sulfates ( $\text{SO}_4^{2-}$ ) except	Barium sulfate ( $\text{BaSO}_4$ ), lead(II) sulfate ( $\text{PbSO}_4$ ) and calcium sulfate ( $\text{CaSO}_4$ )
Ammonium carbonate ( $\text{NH}_4\text{CO}_3$ ), sodium carbonate ( $\text{Na}_2\text{CO}_3$ ), potassium carbonate ( $\text{K}_2\text{CO}_3$ )	All other carbonates

Note that all sodium, potassium and ammonium salts are soluble.



## 2. Preparation of Salts

Soluble salts can be prepared by reacting acids with a suitable reagent. These reagents can be a metal, a carbonate, a basic oxide or an alkali. Insoluble salts are prepared through precipitation.

The following flowchart provides a guide to choosing an appropriate method for preparing a salt.

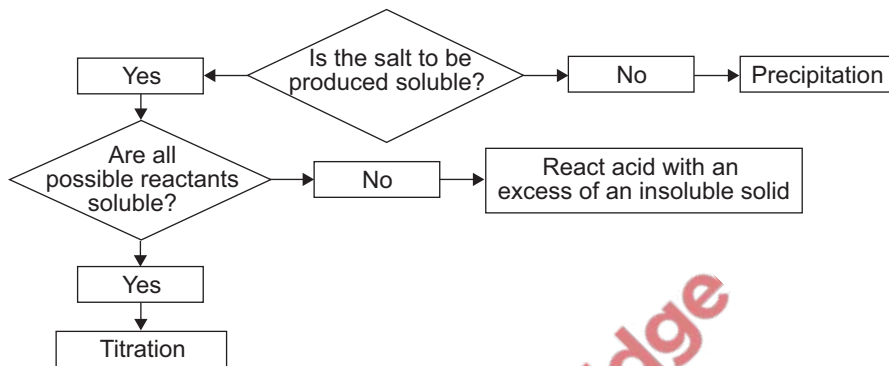

## 3. Preparing Insoluble Salts

Insoluble salts are prepared through precipitation. This is done through mixing two aqueous solutions, one containing the cation of the salt and another containing the anion of the salt. After mixing the two solutions, the salt can be separated through filtration and purified by washing with distilled water.

## 4. Preparing Soluble Salts

Soluble salts can be prepared by reacting an acid with an insoluble solid. The insoluble solid can be a metal, a carbonate or a base. This is done by adding an excess of solid reactant to aqueous acid.

acid + metal  $\rightarrow$  salt + hydrogen gas

acid + insoluble carbonate  $\rightarrow$  salt + carbon dioxide + water

acid + insoluble base  $\rightarrow$  salt + water

The excess solid reactant ensures that the acid is completely reacted. Once the reaction is complete, excess solid can be filtered off to obtain a solution of the salt.

This method does not apply to all solid reactants. Reactive metals such as sodium or calcium cannot be used as they react violently with dilute acids, making the reaction dangerous to perform. Unreactive metals such as copper and silver do not react with dilute acids.

Soluble salts can also be prepared by reacting an acid with a soluble reactant through titration. The reactant can be an alkali or a soluble carbonate.

acid + alkali  $\rightarrow$  salt + water

acid + soluble carbonate  $\rightarrow$  salt + carbon dioxide + water

Since both reactants are soluble, exact quantities of each reactant have to be used to avoid contamination of the final product.

The quantities are obtained by performing titration once with a suitable indicator. An indicator is necessary to determine when the reaction is complete as the reactants used are usually colourless. Titration is then repeated without an indicator when the amount of reactants required has been obtained.

Since all sodium, potassium and ammonium salts are soluble, titration is the best method to prepare these salts.

For both methods mentioned, a pure solid sample of the salt can be obtained through crystallisation or evaporating water off the salt solution.

## 5. Tests for Gases

Gas	Test	Observation
Oxygen, O <sub>2</sub>	Place a glowing splint into the test-tube.	The glowing splint relights.
Hydrogen, H <sub>2</sub>	Place a lighted splint at the mouth of the test-tube.	The lighted splint extinguishes with a 'pop' sound.
Carbon dioxide, CO <sub>2</sub>	Bubble the gas into limewater.	A white precipitate of calcium carbonate forms.
Sulfur dioxide, SO <sub>2</sub>	Place a paper soaked with acidified potassium manganate(VII) at the mouth of the test-tube.	The paper turns from purple to colourless.
Chlorine, Cl <sub>2</sub>	Place a damp blue litmus paper at the mouth of the test-tube.	The blue litmus turns red and is finally bleached white.
Ammonia, NH <sub>3</sub>	Place a damp red litmus paper at the mouth of the test-tube.	The red litmus turns blue.

## 6. Tests for Cations

Cation	Reaction with aqueous sodium hydroxide	Reaction with aqueous ammonia
Aluminium ion, $Al^{3+}$	A white precipitate forms. The precipitate dissolves in excess NaOH to give a colourless solution.	A white precipitate forms. The precipitate is insoluble in excess $NH_3$ .
Calcium ion, $Ca^{2+}$	A white precipitate forms. The precipitate is insoluble in excess NaOH.	No visible change.
Copper(II) ion, $Cu^{2+}$	A light blue precipitate forms. The precipitate is insoluble in excess NaOH.	A light blue precipitate forms. The precipitate dissolves in excess $NH_3$ to give a deep blue solution.
Iron(II) ion, $Fe^{2+}$	A dirty green precipitate forms. The precipitate is insoluble in excess NaOH.	A dirty green precipitate forms. The precipitate is insoluble in excess $NH_3$ .
Iron(III) ion, $Fe^{3+}$	A reddish-brown precipitate forms. The precipitate is insoluble in excess NaOH.	A reddish-brown precipitate forms. The precipitate is insoluble in excess $NH_3$ .
Lead(II) ion, $Pb^{2+}$	A white precipitate forms. The precipitate dissolves in excess NaOH to give a colourless solution.	A white precipitate forms. The precipitate is insoluble in excess $NH_3$ .
Zinc ion, $Zn^{2+}$	A white precipitate forms. The precipitate dissolves in excess NaOH to give a colourless solution.	A white precipitate forms. The precipitate dissolves in excess $NH_3$ to give a colourless solution.
Ammonium ion, $NH_4^+$	No precipitate forms. Ammonia gas is produced on warming.	No visible change.

## 7. Tests for Anions

Anion	Test	Observation
Nitrate ion, $\text{NO}_3^-$	Add aqueous sodium hydroxide and a small piece of aluminium foil, and warm the mixture.	Ammonia gas is released, the gas turns damp red litmus blue.
Carbonate ion, $\text{CO}_3^{2-}$	Add dilute hydrochloric acid.	Carbon dioxide is released, the gas forms a white precipitate when bubbled into limewater.
Chloride ion, $\text{Cl}^-$	Add dilute nitric acid, followed by aqueous silver nitrate.	A white precipitate of silver chloride is produced.
Iodide ion, $\text{I}^-$	Add dilute nitric acid, followed by aqueous lead(II) nitrate.	A yellow precipitate of lead(II) iodide is produced.
Sulfate ion, $\text{SO}_4^{2-}$	Add dilute nitric acid, followed by aqueous barium nitrate.	A white precipitate of barium sulfate is produced.

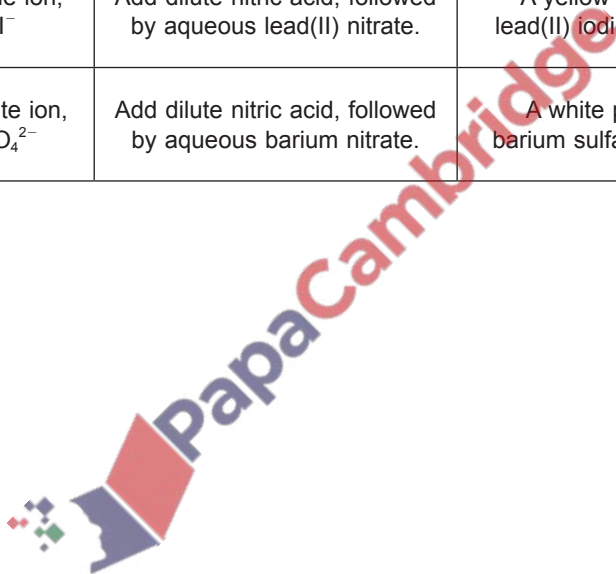

# TOPIC 12

## Oxidation And Reduction

### Objectives

Candidates should be able to:

- define *oxidation* and *reduction* (redox) in terms of oxygen/hydrogen gain/loss
- define redox in terms of electron transfer and changes in oxidation state
- identify redox reactions in terms of oxygen/hydrogen gain/loss, electron gain/loss and changes in oxidation state
- describe the use of aqueous potassium iodide and acidified potassium manganate(VII) in testing for oxidising and reducing agents from the resulting colour changes

### 1. Oxidation and Reduction

Oxidation can be seen as the gain of oxygen, the loss of hydrogen, the loss of electrons or the increase in oxidation number of a substance.

The reverse occurs in reduction. It can be seen as the loss of oxygen, the gain of hydrogen, the gain of electrons or the decrease in oxidation number of a substance.

### 2. Calculating Oxidation Numbers

An element has an oxidation state of 0, regardless of whether it is found as individual atoms or in molecules. For example, neon (Ne) and chlorine ( $\text{Cl}_2$ ) have oxidation states of 0.

The sum of oxidation numbers of all atoms in an uncharged compound is 0. For a polyatomic ion, the sum of oxidation numbers of all atoms is equal to its charge.

The oxidation state of an ion is given by its charge. For example, a magnesium ion  $\text{Mg}^{2+}$  and an oxide ion  $\text{O}^{2-}$  have oxidation states of +2 and -2 respectively.

Some elements have fixed oxidation numbers in compounds. Oxygen usually has the oxidation state of -2 in its compounds. Hydrogen usually has the oxidation state of +1 in its compounds.



Objectives

**Candidates should be able to:**

- (a) describe the general physical properties of metals as solids having high melting and boiling points, malleable, good conductors of heat and electricity in terms of their structure
- (b) describe alloys as a mixture of a metal with another element
- (c) identify representations of metals and alloys from diagrams of structures
- (d) explain why alloys have different physical properties to their constituent elements
- (e) place in order of reactivity calcium, copper, (hydrogen), iron, lead, magnesium, potassium, silver, sodium and zinc by reference to
  - (i) the reactions, if any, of the metals with water, steam and dilute hydrochloric acid,
  - (ii) the reduction, if any, of their oxides by carbon and/or by hydrogen
- (f) describe the reactivity series as related to the tendency of a metal to form its positive ion, illustrated by its reaction with
  - (i) the aqueous ions of the other listed metals
  - (ii) the oxides of the other listed metals
- (g) deduce the order of reactivity from a given set of experimental results
- (h) describe the action of heat on the carbonates of the listed metals and relate thermal stability to the reactivity series
  - (i) describe the ease of obtaining metals from their ores by relating the elements to their positions in the reactivity series
- (j) describe and explain the essential reactions in the extraction of iron using haematite, limestone and coke in the blast furnace
- (k) describe steels as alloys which are a mixture of iron with carbon or other metals and how controlled use of these additives changes the properties of the iron
- (l) state the uses of mild steel
- (m) describe the essential conditions for the corrosion (rusting) of iron as the presence of oxygen and water; prevention of rusting can be achieved by placing a barrier around the metal
- (n) describe the sacrificial protection of iron by a more reactive metal in terms of the reactivity series where the more reactive metal corrodes preferentially, e.g. underwater pipes have a piece of magnesium attached to them

## 1. Physical Properties of Metals

Metals usually have high densities, melting points and boiling points. Some exceptions would be Group I metals (some are less dense than water) and mercury (which is a liquid at room temperature and pressure). Metals are good conductors of heat and electricity, and are often shiny, ductile and malleable.

## 2. Alloys

Pure metals are usually not widely used as they are soft and may corrode easily, therefore alloys are used instead. An alloy is a mixture of a metal and one or more elements, which may be metal or non-metal.

A pure metal is soft due to the regular arrangement of atoms in the metal lattice. The atoms are arranged in neat layers which slide past each other easily when a force is applied.

In an alloy however, the arrangement of atoms is disrupted by the presence of atoms of different sizes. This prevents the layers of atoms from sliding easily, making the alloy harder than the pure metal.

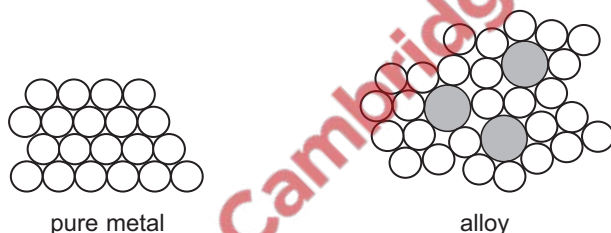

Alloying metals helps to change properties to make it more suitable for a particular use. For instance, an alloy of iron and chromium has greater resistance to rusting compared to pure iron.





### 3. The Reactivity Series

The reactivity series arranges metals in order of reactivity. Metals that are more reactive have a higher tendency of forming ions compared to metals that are less reactive.

most reactive	↑	Potassium	(K)
		Sodium	(Na)
		Calcium	(Ca)
		Magnesium	(Mg)
		Aluminium	(Al)
		(Carbon)	(C)
		Zinc	(Zn)
		Iron	(Fe)
		Lead	(Pb)
		(Hydrogen)	(H)
		Copper	(Cu)
		Silver	(Ag)
least reactive		Gold	(Au)

### 4. Displacement Reactions of Metals

Displacement reaction takes place when a more reactive metal is placed in the salt solution of a less reactive metal. Since the more reactive metal has a higher tendency to form ions, it displaces the less reactive metal from its salt.

For example, when copper metal is placed in a solution of silver nitrate, copper displaces silver from the silver nitrate solution.

copper metal + silver nitrate → copper nitrate + silver

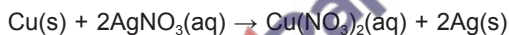

However, no reaction occurs when a less reactive metal is placed in the salt solution of a more reactive metal. No change is seen when copper metal is placed in magnesium sulfate solution since magnesium is more reactive than copper.

## 5. Reactions of Metals with Water

Metal	Observations	Equation
Potassium	Reacts violently with cold water. Hydrogen gas catches fire and explodes.	Reaction with cold water: $2K(s) + 2H_2O(l) \rightarrow 2KOH(aq) + H_2(g)$
Sodium	Reacts violently with cold water. Hydrogen gas may catch fire.	Reaction with cold water: $2Na(s) + 2H_2O(l) \rightarrow 2NaOH(aq) + H_2(g)$
Calcium	Reacts moderately with cold water.	Reaction with cold water: $Ca(s) + 2H_2O(l) \rightarrow Ca(OH)_2(aq) + H_2(g)$
Magnesium	Reacts slowly with cold water. Hot magnesium reacts violently with steam and burns with a white glow.	Reaction with cold water: $Mg(s) + 2H_2O(l) \rightarrow Mg(OH)_2(aq) + H_2(g)$ Reaction with steam: $Mg(s) + H_2O(g) \rightarrow MgO(s) + H_2(g)$
Aluminium	Reacts readily with steam. Reaction slows down due to the formation of a protective oxide layer.	Reaction with steam: $2Al(s) + 3H_2O(g) \rightarrow Al_2O_3(s) + 3H_2(g)$
Zinc	Hot zinc reacts readily with steam. Zinc oxide produced is yellow when hot and white when cold.	Reaction with steam: $Zn(s) + H_2O(g) \rightarrow ZnO(s) + H_2(g)$
Iron	Hot iron reacts slowly with steam.	Reaction with steam: $3Fe(s) + 4H_2O(g) \rightarrow Fe_3O_4(s) + 4H_2(g)$
Lead	No reaction	-
Copper	No reaction	-
Silver	No reaction	-
Gold	No reaction	-

## 6. Reactions of Metals with Dilute Hydrochloric Acid

Metal	Observations	Equation
Potassium	Reacts violently	$2K(s) + 2HCl(aq) \rightarrow 2KCl(aq) + H_2(g)$
Sodium	Reacts violently	$2Na(s) + 2HCl(aq) \rightarrow 2NaCl(aq) + H_2(g)$
Calcium	Reacts violently	$Ca(s) + 2HCl(aq) \rightarrow CaCl_2(aq) + H_2(g)$
Magnesium	Reacts readily	$Mg(s) + 2HCl(aq) \rightarrow MgCl_2(aq) + H_2(g)$
Aluminium	Reacts readily	$2Al(s) + 6HCl(aq) \rightarrow 2AlCl_3(aq) + 3H_2(g)$
Zinc	Reacts moderately fast	$Zn(s) + 2HCl(aq) \rightarrow ZnCl_2(aq) + H_2(g)$
Iron	Reacts slowly	$Fe(s) + 2HCl(aq) \rightarrow FeCl_2(aq) + H_2(g)$
Lead	No reaction	-
Copper	No reaction	-
Silver	No reaction	-
Gold	No reaction	-

Reactions of metals with dilute hydrochloric acid can be seen as the displacement of hydrogen in the acid by a more reactive metal.

While lead is higher than hydrogen in the series, it does not react with dilute hydrochloric acid due to the formation of an insoluble layer of lead(II) chloride. The salt acts as a protective layer and prevents the acid from reacting further with the metal.

## 7. Extraction of Metals

Metals are usually found in nature as ores, which mainly consist of metal oxides. The extraction of a metal from its ore depends on its reactivity. A more reactive metal usually requires tougher methods of extraction compared to a less reactive metal.

Zinc and metals lying below it in the reactivity series can be extracted from their oxides through heating with carbon.

Aluminium and other metals above it in the reactivity series form very stable oxides that are not easily reduced. They can only be extracted from their ores through electrolysis of their molten oxides.

## 8. Thermal Stability of Metal Carbonates

Reactive metals form very stable carbonates which do not decompose easily upon heating. On the other hand, the carbonates of metals which are less reactive are easily decomposed by heat.

Carbonates of potassium and sodium are thermally stable since these metals are found high in the reactivity series. Carbonates of calcium, magnesium, zinc, iron, lead and copper decompose upon heating to form metal oxide and carbon dioxide.

Silver carbonate is the least stable since silver metal is the least reactive. It decomposes completely into silver metal and carbon dioxide.

## 9. Extraction of Iron

Iron is extracted from its ore, haematite (contains iron(III) oxide,  $\text{Fe}_2\text{O}_3$ ), by heating with carbon. Haematite, coke (mainly carbon) and limestone (calcium carbonate,  $\text{CaCO}_3$ ) are loaded at the top of the blast furnace while hot air is introduced at the bottom of the furnace.

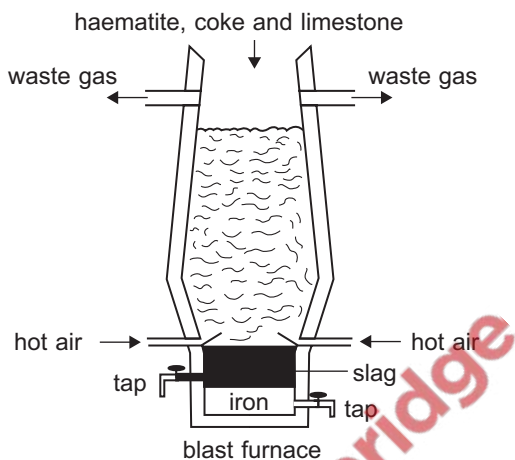

1. Coke is oxidised by oxygen in the hot air in an exothermic reaction.

carbon + oxygen  $\rightarrow$  carbon dioxide

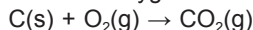

Carbon dioxide then further reacts with carbon to produce carbon monoxide.

carbon dioxide + carbon  $\rightarrow$  carbon monoxide

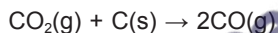

2. Carbon monoxide reduces iron(III) oxide in haematite to molten iron. Since iron has high density, it sinks to the bottom of the furnace.

iron(III) oxide + carbon monoxide  $\rightarrow$  molten iron + carbon dioxide



3. Limestone undergoes thermal decomposition.

calcium carbonate  $\rightarrow$  calcium oxide + carbon dioxide



Silicon dioxide, an acidic impurity, is removed by reacting with calcium oxide, which is basic in nature.

calcium oxide + silicon dioxide  $\rightarrow$  calcium silicate (slag)

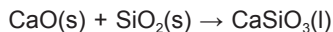

The reaction forms slag, which floats on top of molten iron. The molten iron and slag are tapped off separately at the bottom of the furnace.

## 10. Steel

Steel is an alloy of iron and carbon. The properties of steel can be further altered by the addition of other metals and controlling the amounts of these components.

Molten iron produced from the blast furnace is known as pig iron or cast iron and contains many impurities. These impurities can be removed by introducing oxygen through the molten iron. Removal of these impurities leaves behind pure iron, which is also known as wrought iron.

Different percentages of carbon may be added to wrought iron to form steel. Low-carbon steel (or mild steel) is hard and malleable and can be used to make car bodies. High-carbon steel is harder but more brittle than low-carbon steel and is used to make cutting tools.

Stainless steel is a mixture of iron, carbon, chromium and nickel. Addition of these elements makes it more resistant to corrosion and hence, makes it suitable for use as cutlery or surgical tools.

## 11. Rusting of Iron

Iron corrodes in the presence of water and oxygen to form rust (hydrated iron(III) oxide).

iron + oxygen + water → hydrated iron(III) oxide

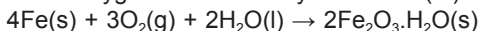

Rusting can be prevented by painting or covering the metal with a layer of oil. This protects iron from being exposed to oxygen and water.

Sacrificial protection can be used to prevent rusting. A more reactive metal is used as the sacrificial metal and corrodes in place of iron. This is usually done by attaching a block of magnesium or zinc to the iron, or galvanisation, where iron is coated with zinc.

Plating iron with zinc also protects the metal from direct contact with water and oxygen.

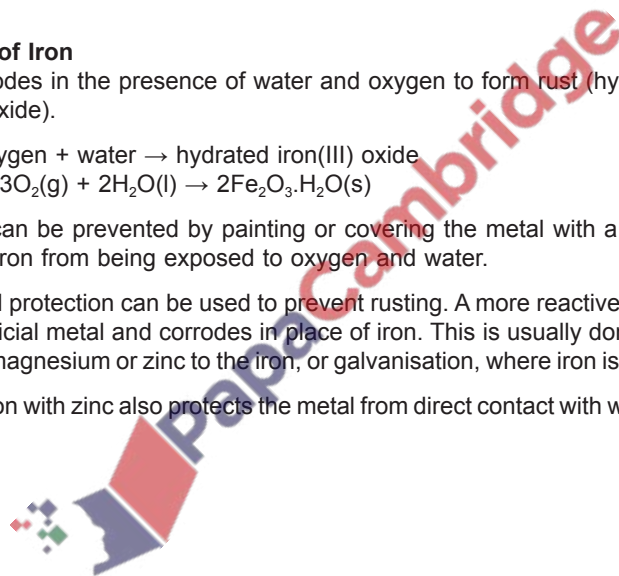

# TOPIC 14

## Electrolysis

### Objectives

#### Candidates should be able to:

- describe electrolysis as the conduction of electricity by an ionic compound (an electrolyte), when molten or dissolved in water, leading to the decomposition of the electrolyte
- describe electrolysis as evidence for the existence of ions which are held in a lattice when solid but which are free to move when molten or in solution
- describe, in terms of the mobility of ions present and the electrode products, the electrolysis of molten sodium chloride, using inert electrodes
- predict the likely products of the electrolysis of a molten binary compound
- apply the idea of selective discharge based on
  - cations: linked to the reactivity series
  - anions: halides, hydroxides and sulfates
  - concentration effects (In all cases above, inert electrodes are used.)
- predict the likely products of the electrolysis of an aqueous electrolyte, given relevant information
- construct ionic equations for the reactions occurring at the electrodes during the electrolysis, given relevant information
- describe the electrolysis of aqueous copper(II) sulfate with copper electrodes as a means of purifying copper
  - describe the electroplating of metals
  - describe the production of electrical energy from simple cells (i.e. two electrodes in an electrolyte) linked to the reactivity series and redox reactions (in terms of electron transfer)

### 1. Electrolytic Cell

Electrolysis is the use of electricity to break down a compound into its constituents. The process takes place in an electrolytic cell.

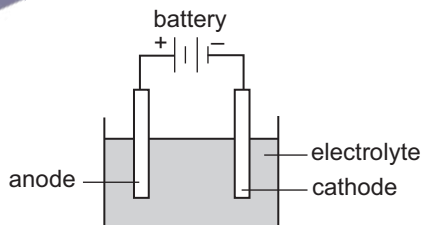

The battery provides a source of electricity for reactions to occur. During the process, electrons flow from the positive terminal to the negative terminal of the battery.

The electrodes used in electrolysis conduct electricity. Inert graphite or platinum electrodes are usually used.

The electrode connected to the positive terminal of the battery is the anode and the electrode connected to the negative terminal of the battery is the cathode. Reduction occurs at the cathode while oxidation occurs at the anode.

The electrolyte contains mobile ions which allow for electricity to flow through. It is usually an acid solution, or an ionic compound that is molten or dissolved in water. A solid ionic compound cannot be used as its ions are in fixed positions in the crystal lattice structure.

## 2. Electrolysis of Molten Ionic Compounds

When an ionic compound is molten, it splits up into positive ions (cations) and negative ions (anions) which are free to move to the cathode and the anode respectively.

At the cathode, electrons are taken in by cations, while at the anode, electrons are lost by anions. To maintain a complete electrical circuit, the number of electrons taken in at the cathode must be the same as the number of electrons lost at the anode.

Since cations take in electrons, they are reduced. Anions are oxidised as they lose electrons.

## 3. Electrolysis of Solutions of Ionic Compounds

When a solution of an ionic compound is used instead, the autoionisation of water has to be taken into consideration as well.

Water partially dissociates to form hydrogen and hydroxide ions.

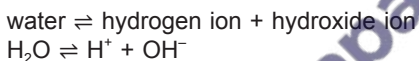

These ions will compete with those of the ionic compound to be discharged at each of the electrodes.

The ease of discharge of cations can be predicted based on the reactivity series. As reactive metals tend to form ions, their ions are not easily discharged. Ions of less reactive metals have a higher tendency of getting discharged as they accept electrons more easily.

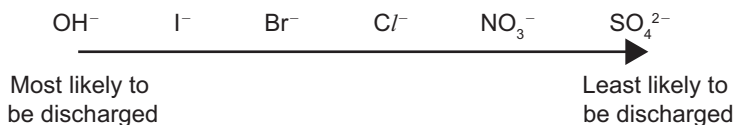

Hydroxide ions are most readily discharged in dilute solutions. Nitrates and sulfates are usually not discharged and tend to stay in the solution.

However, when the solution is concentrated, halide ions are preferentially discharged rather than hydroxide ions.

## 5. Purification of Copper

Copper can be purified by electrolysing copper(II) sulfate solution using copper electrodes. Impure copper is used as the anode while pure copper acts as the cathode.

At the anode,  $\text{OH}^-$  ions are not discharged since the electrode is not inert. Instead, copper atoms are oxidised to form  $\text{Cu}^{2+}$  ions.



The impure copper anode gradually dissolves as the atoms are oxidised. The impurities are left behind to sink to the bottom of the cell as the anode dissolves.

At the cathode,  $\text{Cu}^{2+}$  ions in the electrolyte are discharged and deposited on the pure copper.

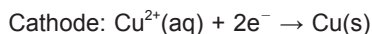

The pure copper cathode gains mass as a layer of pure copper is deposited.

## 6. Electroplating

Electroplating is done to coat a metal with another metal to improve its appearance or to improve its resistance to corrosion.

The metal used for plating is used as the anode and the object to be electroplated acts as the cathode. The electrolyte used is the salt solution of the metal used for plating.

The plating of an object with copper metal is shown below.

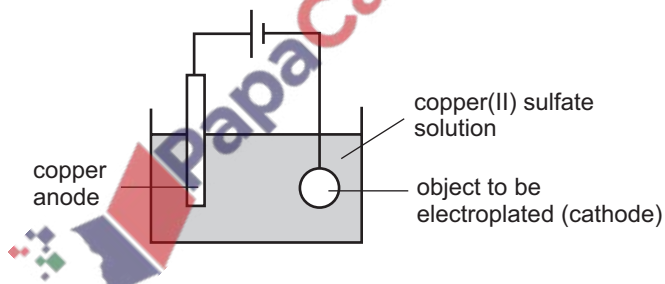

Copper metal acts as the anode as it is used to plate the object. The electrolyte used is a salt solution of its salt (copper(II) sulfate solution) and the object to be plated acts as the cathode.

At the anode, the copper atoms are oxidised into  $\text{Cu}^{2+}$  ions, which enter the electrolyte. At the cathode,  $\text{Cu}^{2+}$  ions are discharged and deposited on the object, plating it with copper metal.



## 7. Simple Cells

Simple cells convert chemical energy into electrical energy. The cell uses two different metals as electrodes and the voltage produced varies depending on the metals used.

In such a cell, the more reactive metal acts as the anode while the less reactive metal acts as the cathode.

In a zinc-copper cell, zinc metal acts as the anode while copper acts as the cathode.

At the anode, zinc oxidises to form  $\text{Zn}^{2+}$  ions. In the process, electrons are released and they flow out of the anode through the wire.



Electrons flow from the zinc anode to the copper cathode, where  $\text{Cu}^{2+}$  ions in the electrolyte are reduced and deposited as copper metal on the cathode.

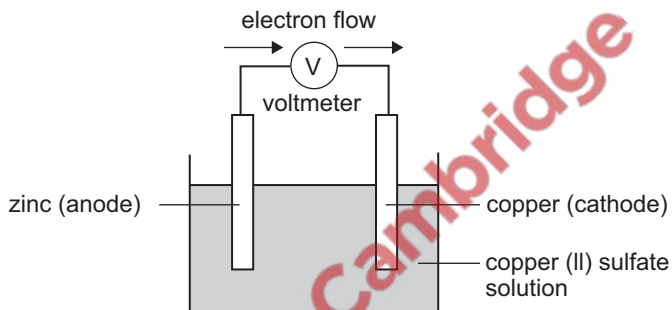
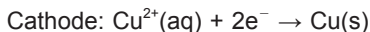

The zinc anode gradually loses mass as zinc atoms get oxidised while the copper cathode gains mass as  $\text{Cu}^{2+}$  ions are reduced and deposited. The overall equation of the reaction is obtained by adding the half-equations.



A greater voltage is produced when the two metals used are far apart in the reactivity series. A magnesium-copper cell generates a higher voltage than a zinc-copper cell since the difference in reactivity is greater in the magnesium-copper cell.

# TOPIC 15

## Periodic Table

### Objectives

#### Candidates should be able to:

- (a) describe the Periodic Table as an arrangement of the elements in the order of increasing proton (atomic) number
- (b) describe how the position of an element in the Periodic Table is related to proton number and electronic structure
- (c) describe the relationship between group number and the ionic charge of an element
- (d) explain the similarities between the elements in the same group of the Periodic Table in terms of their electronic structure
- (e) describe the change from metallic to non-metallic character from left to right across a period of the Periodic Table
- (f) describe the relationship between group number, number of valency electrons and metallic/non-metallic character
- (g) predict the properties of elements in Group I and Group VII using the Periodic Table
- (h) describe lithium, sodium and potassium in Group I (the alkali metals) as a collection of relatively soft, low density metals showing a trend in melting point and in their reaction with water
- (i) describe chlorine, bromine and iodine in Group VII (the halogens) as a collection of diatomic non-metals showing a trend in colour, state and their displacement reactions with solutions of other halide ions
- (j) describe the elements in Group 0 (the noble gases) as a collection of monatomic elements that are chemically unreactive and hence important in providing an inert atmosphere
- (k) describe the lack of reactivity of the noble gases in terms of their electronic structures
- (l) describe the transition elements as metals having high melting points, high density, variable oxidation state and forming coloured compounds
- (m) state that the elements and/or their compounds are often able to act as catalysts

#### 1. Features of the Periodic Table

Elements are arranged in order of increasing atomic numbers in the Periodic Table. They are organised into horizontal rows known as periods, and vertical columns known as groups.

#### 2. Metals and Non-metals

Elements can be classified as metals or non-metals. There is also a class of elements known as metalloids, which exhibit both metal and non-metal properties. These elements are found along the diagonal line in the Periodic Table.

### 3. Variations Across a Period

In a period, metals are found on the left side while the non-metals are found on the right side. The metallic character of elements decreases as we move from left to right of a period.

Elements in the same period have the same number of electron shells. The number of electron shells corresponds with the period number of the element. For example, aluminium belongs to Period 3 and has three electron shells.

### 4. Variations Down a Group

The metallic character of elements increases as we move down a group. This is due to the increase in size of atoms. Valence electrons are further away from the nucleus of the atom and are not as strongly attracted.

Larger atoms in the group will lose their valence electrons more easily than smaller atoms. Therefore, moving down a group, there is an increase in metallic character.

Elements in the same group have the same number of valence electrons. The number of valence electrons each of the elements has corresponds with the group number. For instance, Group I elements (e.g. lithium, sodium, potassium) each have one valence electron each while Group II elements (e.g. boron, magnesium, calcium) have two valence electrons each.

### 5. Group I: Alkali Metals

Elements in Group I are also known as alkali metals. The atoms of these elements have one valence electron each. These metals are soft and can be cut easily with a knife. They have relatively low melting and boiling points. Their densities are relatively low. Lithium, sodium and potassium have densities lower than water, enabling them to float.

Moving down the group, the melting and boiling points decrease while the densities increase.

Alkali metals are highly reactive metals. They react easily with oxygen and water.

The reactivity of these metals increases as we move down the group. This is due to an increase in the atom size, which means that the valence electrons are further away from the nucleus and are more easily lost.

Alkali metals react with water to form an alkali and hydrogen gas. The trend in reactivity can be observed from their reactions with water. Lithium reacts quickly with cold water, but potassium reacts very violently with cold water.

As alkali metals easily give away their valence electrons, they are strong reducing agents. These metals react with non-metals to form ionic salts which are soluble in water.

## 6. Group VII: Halogens

Elements in Group VII are also known as halogens. Atoms of these elements have seven valence electrons each.

These are non-metals that are found as diatomic molecules (e.g.  $Cl_2$ ,  $Br_2$ ,  $I_2$ ). Since they are found as simple covalent molecules, they have low melting and boiling points. They are coloured substances.

Moving down the group, the melting and boiling points increase. At the same time, the colour intensity of these elements increases. This can be observed from their physical properties at room temperature and pressure. Chlorine is a yellow-green gas, bromine is a reddish-brown liquid and iodine is a black solid.

Halogens are highly reactive non-metals as they only need to gain one electron for a noble gas electronic configuration.

The reactivity decreases as we move down the group. As the atoms increase in size, the force of attraction between the valence shell electrons and the nucleus is weaker. As a result, larger halogens do not gain electrons as easily as smaller ones. Out of the three halogens, chlorine is the most reactive while iodine is the least reactive.

Halogens undergo displacement reaction, where a more reactive halogen displaces a less reactive halogen from its salt. For instance, when chlorine gas is bubbled into sodium bromide solution, bromide ions get displaced. The solution changes from colourless to reddish-brown as bromine molecules are produced in the reaction.

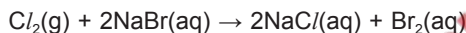

As halogens accept electrons easily, they are strong oxidising agents.

## 7. Group VIII: Noble Gases

Elements in Group VIII (or sometimes referred to as Group 0) are known as noble gases. These are inert non-metals which are found as monatomic gases. Their lack of reactivity is due to their complete shell of valence electrons, hence they rarely react to form compounds.

Due to their unreactive nature, noble gases are often used to provide an inert atmosphere. The following table shows some applications of noble gases.

Element	Application
Helium	Weather balloons
Neon	Advertising signs or lights
Argon	Lightbulbs or welding
Krypton	Lasers
Xenon	Photographic flashes or lamps in motion picture projection

## 8. Transition Elements

Transition elements are a block of metals found between Groups II and III in the Periodic Table. These metals have high melting and boiling points and high densities. Compounds of transition elements are usually coloured.

Transition elements have variable oxidation states. They can form ions of different charges, as opposed to Group I or Group VII elements, which usually form ions of a single charge. For example, iron commonly forms  $\text{Fe}^{2+}$  and  $\text{Fe}^{3+}$  ions.

Transition elements and their compounds are good catalysts and are commonly used in industrial processes. For example, nickel is used in the manufacture of margarine (hydrogenation of vegetable oil) and iron is used in the Haber process (manufacture of ammonia).

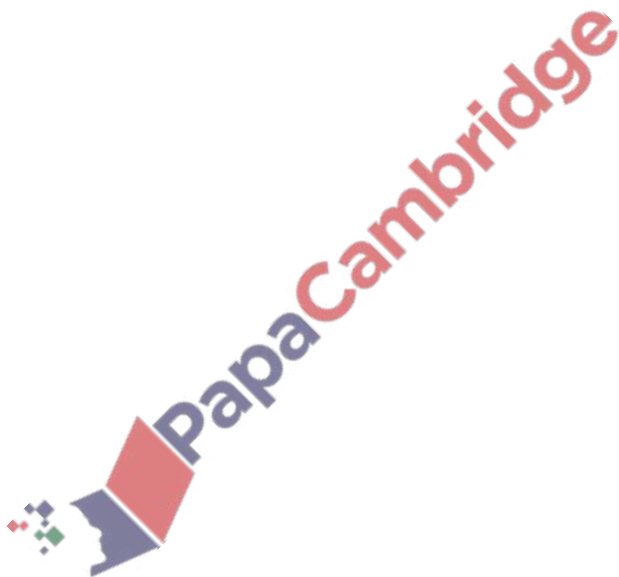

# TOPIC 16

## Energy Changes

### Objectives

Candidates should be able to:

- describe the meaning of enthalpy change in terms of exothermic ( $\Delta H$  negative) and endothermic ( $\Delta H$  positive) reactions
- represent energy changes by energy profile diagrams, including reaction enthalpy changes and activation energies
- describe bond breaking as an endothermic process and bond making as an exothermic process
- explain overall enthalpy changes in terms of the energy changes associated with the breaking and making of covalent bonds
- describe hydrogen, derived from water or hydrocarbons, as a potential fuel, reacting with oxygen to generate electricity directly in a fuel cell

### 1. Enthalpy Change

The enthalpy change of a reaction is the amount of energy involved in the reaction and is represented by the symbol  $\Delta H$ .

### 2. Exothermic and Endothermic Changes

In an exothermic change, heat is released into the surroundings and this is detected as a rise in temperature. Examples of such processes include condensation, freezing, neutralisation reactions, combustion of fuels and respiration.

In an endothermic change, heat is absorbed from the surroundings and this is detected as a drop in temperature. Examples of such processes include evaporation, melting, dissolving of ammonium chloride, photosynthesis and thermal decomposition.

The enthalpy change of a chemical reaction can be calculated as follows.

$$\Delta H = \text{Total energy of products} - \text{Total energy of reactants}$$

For an exothermic reaction, the total energy of the reactants is greater than the total energy of the products, i.e.  $\Delta H < 0$ .

For an endothermic reaction, the total energy of the products is greater than the total energy of the reactants, i.e.  $\Delta H > 0$ .

### 3. Bond Making and Bond Breaking

Energy is released when bonds are made and energy is absorbed when bonds are broken, i.e. bond making is an exothermic process while bond breaking is an endothermic process.

The enthalpy change of a reaction can be calculated by taking the difference between the energy required for bond breaking and the energy required for bond making.

$$\Delta H = \text{Total energy absorbed for bond breaking} - \text{Total energy released for bond making}$$

Since  $\Delta H < 0$  for an exothermic reaction, the energy released for bond making is greater than the energy absorbed for bond breaking. For an endothermic reaction where  $\Delta H > 0$ , the energy absorbed for bond breaking is greater than the energy released for bond making.

### 4. Activation Energy

Reactant particles must overcome an energy barrier before they can form products. They must possess a minimum amount of energy for this to occur. The minimum energy required for reactants to form products is the activation energy. Particles that have energy that is equal to or greater than the activation energy will be able to react.

### 5. Energy Level Diagram

An energy level diagram shows both the enthalpy change and activation energy of a reaction.

For an exothermic reaction, the total energy of the reactants is higher than the total energy of the products.

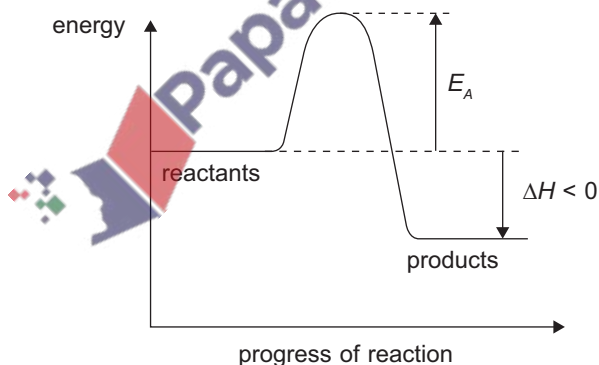

For an endothermic reaction, the total energy of the products is higher than the total energy of the reactants.

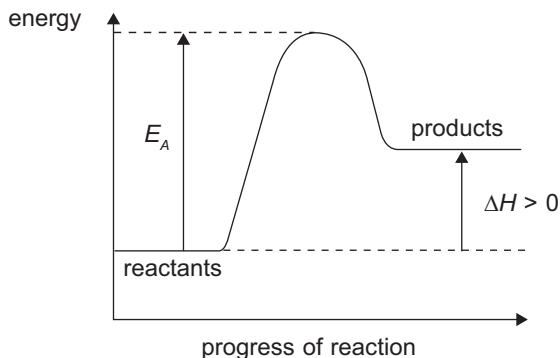

## 6. Fuels

Fuels are substances that are burned to release energy. Fossil fuels are commonly used and they undergo complete combustion with excess oxygen to produce carbon dioxide and water.

Apart from combustion of fossil fuels, fuel cells can also be used to release energy. One such fuel cell is a hydrogen-oxygen fuel cell. In such a cell, oxygen is reduced at the anode to form hydroxide ions while hydrogen is oxidised to form water.

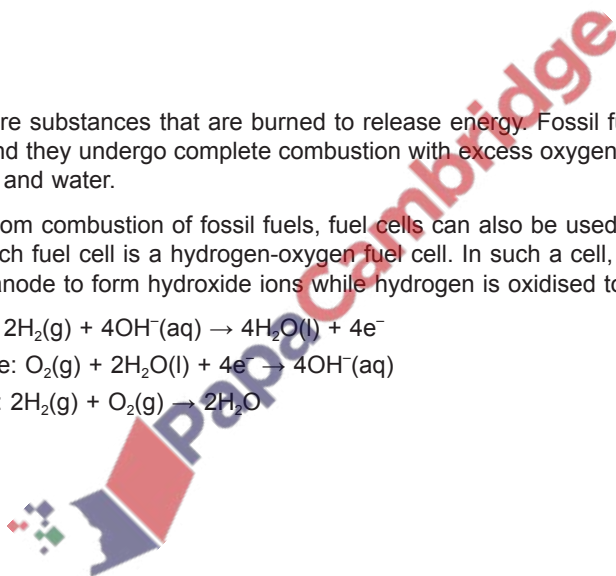
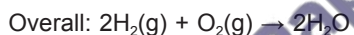
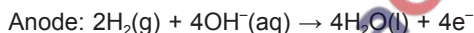



Objectives

Candidates should be able to:

- describe the effect of concentration, pressure, particle size and temperature on the speeds of reactions and explain these effects in terms of collisions between reacting particles
- define the term *catalyst* and describe the effect of catalysts (including enzymes) on the speeds of reactions
- explain how pathways with lower activation energies account for the increase in speeds of reactions
- state that some compounds act as catalysts in a range of industrial processes and that enzymes are biological catalysts
- suggest a suitable method for investigating the effect of a given variable on the speed of a reaction
- interpret data obtained from experiments concerned with speed of reaction

1. Measuring Speed of Reaction

The speed of reaction can be obtained by measuring quantities of reactants or products at regular time intervals. These quantities can then be plotted against time to give an overview of the speed of reaction at different times.

For a reaction that has a gaseous product, the speed of reaction can be obtained by measuring the speed at which gas is produced. This is done by measuring the volume of gas produced at regular time intervals.

The experimental set-up for collecting and measuring the gas is as shown.

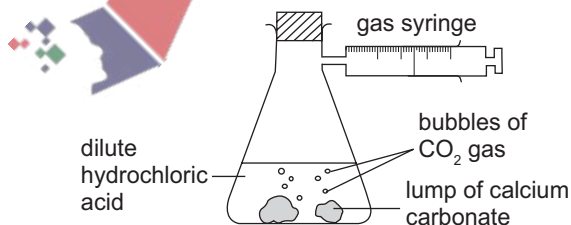

The speed of reaction for reactions with gaseous products can also be obtained by measuring the speed at which the reactants are used up. This is done by measuring the mass of the reaction mixture at regular time intervals.

The experimental set-up for measuring the decrease in the mass of the reaction mixture is as follows.

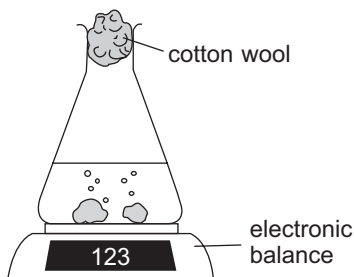

The gradient of the graph gives the speed of reaction. A large gradient (or a steep slope) indicates that the speed of reaction is high while a small gradient (or a gentle slope) indicates a low speed of reaction. When the reaction stops, the gradient is zero.

The graph with values obtained from the amount of reactants has a negative slope. Conversely, the slope of the graph with values obtained from the amount of products has a positive slope.

## 2. Effective Collisions

Before a reaction can occur, there must be effective collisions between reactant particles. This means that reactant particles must collide in the correct orientation, with the minimum required energy. The speed of reaction is affected by the rate at which effective collisions occur. A higher frequency of effective collisions leads to a greater speed of reaction.

## 3. Factors Affecting the Speed of Reaction

The concentration of reactants affects the speed of reactions that involve aqueous reactants. With a higher concentration of reactants, the speed of reaction increases. This occurs as there are more reactant particles per unit volume, therefore the frequency of effective collisions increases.

Pressure affects the speed of reactions that involve gases. Increasing the pressure of gaseous reactants can be seen as increasing its concentration as there are more reactants per unit volume. Therefore at higher pressures, the speed of reaction increases since the frequency of effective collisions is higher.

For reactions involving solid reactants, increasing the total exposed surface area results in a greater speed of reaction. This happens when a large piece of reactant is broken into smaller pieces. With a greater surface area exposed, there are more places for other reactants to collide with. This results in a higher frequency of effective collisions.

The speed of reaction increases with an increase in temperature. At lower temperatures, reactant particles move slowly and do not collide with sufficient energy. At higher temperatures, reactant particles have more kinetic energy. They are then able to move faster and collide more frequently. As a result, more particles possess sufficient energy for effective collisions to occur. This results in a higher frequency of effective collisions.

The presence of a catalyst increases the speed of reaction by providing an alternate reaction pathway that has lower activation energy. There will be more reactant particles that possess sufficient energy for effective collisions. Therefore a catalysed reaction would proceed faster than an uncatalysed reaction.

#### 4. Catalysts

A catalyst is a substance that increases the speed of reaction by lowering the energy barrier required for a reaction to proceed. It remains chemically unchanged at the end of a reaction. Only a small amount of catalyst is required to speed up a reaction.

The effect of a solid catalyst can be improved by increasing its surface area. When a catalyst has a smaller particle size, there is a greater surface area on which reactions can take place.

Note that catalysts only lower the activation energy of a reaction, but do not alter the energy of the reactants or products.

Some common catalysts used in industries are as shown in the following table.

Catalyst	Application
Iron	Haber process (manufacture of ammonia)
Platinum	Catalytic converters
Aluminium oxide (alumina) or silicon dioxide (silica)	Cracking of large hydrocarbons
Nickel	Hydrogenation of alkenes

Enzymes are biological catalysts that catalyse biochemical reactions in living organisms. They are proteins and can only catalyse one type or one class of reactions. These catalysts work best at certain temperature and pH ranges.

The fermentation of glucose uses enzymes which are produced from yeast to catalyse the formation of ethanol. The process takes place at approximately 37 °C since these enzymes work best at this temperature. If temperatures are too low, the enzymes would be inactive. On the other hand, if temperatures are too high, the enzymes would be denatured and can no longer catalyse reactions.

Objectives

Candidates should be able to:

- (a) describe the use of nitrogen, from air, and hydrogen, from the cracking of crude oil, in the manufacture of ammonia
- (b) state that some chemical reactions are reversible, e.g. manufacture of ammonia
- (c) describe the essential conditions for the manufacture of ammonia by the Haber process
- (d) describe the displacement of ammonia from its salts

1. The Haber Process

Ammonia is an important chemical that is manufactured in large amounts through the Haber process. It is produced from nitrogen gas and hydrogen gas. Nitrogen gas is obtained directly from the air and hydrogen gas is obtained from the cracking of large hydrocarbons.

As the formation of ammonia from hydrogen and nitrogen is a reversible process, reaction conditions are controlled to maximise the yield of ammonia.

nitrogen + hydrogen  $\rightleftharpoons$  ammonia

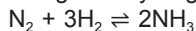

The production of ammonia is favoured at low temperatures. These low temperatures however, are kinetically unfavourable as the reaction would proceed too slowly. Therefore a relatively high temperature of 450 °C is used.

Higher pressures result in a higher yield of ammonia. Despite this, it is expensive to generate and maintain high pressures and have equipment that can withstand the extreme pressures. Considering these costs, the Haber process usually takes place at 250 atm.

An iron catalyst is also used to further increase the rate of reaction.

## 2. Displacement of Ammonia

Ammonia is displaced when ammonium salts are heated with alkalis.

ammonium chloride + sodium hydroxide → ammonia + sodium chloride + water

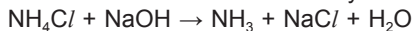

## 3. Fertilisers

Nitrogen is needed for the production of proteins for healthy plant growth. While nitrogen is abundant in the air, most plants cannot utilise atmospheric nitrogen. Nitrogen is supplied to plants in the form of ammonium salts and urea.

Ammonium fertilisers cannot be added alongside agricultural lime (calcium hydroxide and calcium oxide) as ammonia would be displaced from ammonium salts. This causes wastage of the fertiliser as ammonia gas cannot be utilised by plants.

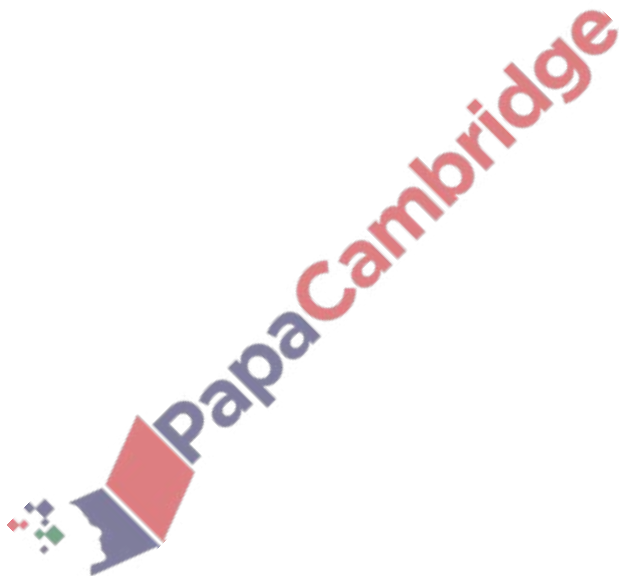

# TOPIC 19

## Air and Atmosphere

### Objectives

#### Candidates should be able to:

- (a) describe the volume composition of gases present in dry air as being approximately 78% nitrogen, 21% oxygen and the remainder being noble gases (with argon as the main constituent) and carbon dioxide
- (b) name some common atmospheric pollutants
- (c) state the sources of these pollutants as
  - (i) carbon monoxide from incomplete combustion of carbon-containing substances
  - (ii) nitrogen oxides from lightning activity and internal combustion engines
  - (iii) sulfur dioxide from volcanoes and combustion of fossil fuels
- (d) describe the reactions used in possible solutions to the problems arising from some of the pollutants named in (b)
  - (i) the redox reactions in catalytic converters to remove combustion pollutants
  - (ii) the use of calcium carbonate to reduce the effect of 'acid rain' and in flue gas desulfurisation
- (e) discuss some of the effects of these pollutants on health and on the environment
  - (i) the poisonous nature of carbon monoxide
  - (ii) the role of nitrogen dioxide and sulfur dioxide in the formation of 'acid rain' and its effects on respiration and buildings
- (f) discuss the importance of the ozone layer and the problems involved with the depletion of ozone by reaction with chlorine containing compounds, chlorofluorocarbons (CFCs)
- (g) describe the carbon cycle in simple terms, to include
  - (i) the processes of combustion, respiration and photosynthesis
  - (ii) how the carbon cycle regulates the amount of carbon dioxide in the atmosphere
- (h) state that carbon dioxide and methane are greenhouse gases and may contribute to global warming, give the sources of these gases and discuss the possible consequences of an increase in global warming

#### 1. Composition of Air

Dry air consists of approximately 79% nitrogen, 20% oxygen, 0.97% noble gases and 0.03% carbon dioxide. The percentage of water vapour present in the air varies across geographical locations.

## 2. Fractional Distillation of Air

As air is a mixture of gases, it can be separated into its components through fractional distillation.

Air is first liquefied by cooling and compressing. Liquid air is then boiled and passed through a fractionating column, where the fractions are distilled and tapped off based on their boiling points. The component with the lowest boiling point is distilled first.

Nitrogen boils at  $-196\text{ }^{\circ}\text{C}$  and is distilled first. Argon and oxygen have boiling points of  $-186\text{ }^{\circ}\text{C}$  and  $-183\text{ }^{\circ}\text{C}$  respectively and are distilled later.

## 3. Carbon Monoxide

Carbon monoxide is a toxic, colourless and odourless gas that is produced from incomplete combustion of carbon-containing substances.

The gas forms a stable compound with haemoglobin in red blood cells, preventing oxygen from binding with it. This deprives cells of oxygen and leads to headaches, fatigue or death.

## 4. Oxides of Nitrogen

Nitrogen combines with oxygen in various ratios to form different types of oxides. These oxides are collectively known as oxides of nitrogen (or  $\text{NO}_x$ ). Two such oxides include nitrogen monoxide (NO) and nitrogen dioxide ( $\text{NO}_2$ ).

They are formed at high temperatures, such as in a combustion engine or by lightning. These high temperatures encourage nitrogen and oxygen present in the atmosphere to react.

Being acidic oxides, they cause acid rain when dissolved in rain water. When inhaled directly, the gas irritates lung tissues and the eyes.

## 5. Sulfur Dioxide

Sulfur dioxide is a pungent and colourless gas. It is naturally produced in large quantities during volcanic eruptions. Burning of fossil fuels also releases sulfur dioxide due to the presence of sulfur in fuels.

It is an acidic oxide that dissolves in rain water to form acid rain. Like oxides of nitrogen, inhaling sulfur dioxide causes respiratory problems and irritates the eyes.

## 6. Unburnt Hydrocarbons and Ozone

Unburnt hydrocarbons are released due to incomplete combustion of fuels. Breathing in these gases may cause cancer.

Ozone is produced when oxides of nitrogen react with unburnt hydrocarbons in the presence of sunlight. At ground level, ozone is a pollutant as breathing the gas causes respiratory problems.

## 7. Acid Rain

While pure water has a pH of 7, rain water is usually slightly acidic in unpolluted areas. This is due to the dissolving of carbon dioxide to form a carbonic acid (a weak acid).

In polluted areas where oxides of nitrogen and sulfur dioxide are present, rain water becomes more acidic. This is due to the formation of strong acids in rain water, such as nitric acid, nitrous acid and sulfurous acid.

Acid rain reacts with structures with metal or carbonates, causing them to corrode and be destroyed. It destroys aquatic habitats by making them too acidic for aquatic life. The soil pH is also greatly lowered, making it unsuitable for plants to survive.

## 8. Catalytic Converters

Catalytic converters are installed in exhaust systems of cars to reduce the emissions of carbon monoxide, oxides of nitrogen and unburnt hydrocarbons. These substances undergo redox reactions in the presence of platinum and rhodium catalysts to form substances that are less harmful.

Carbon monoxide is oxidised to form carbon dioxide.

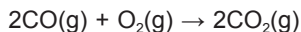

Oxides of nitrogen are reduced to form nitrogen.

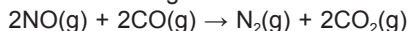

Unburnt hydrocarbons are further oxidised to form carbon dioxide and water.

## 9. Flue Gas Desulfurisation

Sulfur dioxide is removed from waste gases emitted from industrial processes through flue gas desulfurisation. This involves passing the waste gases through calcium carbonate or calcium oxide. Sulfur dioxide is removed from these gases as it reacts with basic substances.

sulfur dioxide + calcium carbonate  $\rightarrow$  calcium sulfite + carbon dioxide

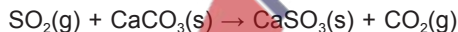

sulfur dioxide + calcium oxide  $\rightarrow$  calcium sulfite



Calcium sulfite undergoes further oxidation with atmospheric oxygen to form calcium sulfate.

calcium sulfite + oxygen  $\rightarrow$  calcium sulfate

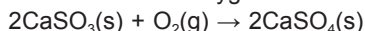

## 10. Ozone Layer

The ozone layer is found high in the Earth's atmosphere. Although ozone is regarded as an air pollutant at ground level, the ozone layer has an important role of absorbing excess ultraviolet (UV) radiation from the Sun.



It has been found that the ozone layer is depleting and substances such as chlorofluorocarbons (CFCs) contribute to this. CFCs are compounds that contain chlorine, fluorine and carbon.

Chlorine radicals are produced when CFCs are exposed to UV radiation. These free radicals destroy the ozone layer by reacting with ozone molecules.

Ozone depletion would cause more UV radiation to reach the Earth's surface, which becomes a problem as excess UV radiation causes health issues such as skin cancer and formation of eye cataracts.

The use of CFCs has since been banned in most countries. Despite this, ozone depletion will continue as CFCs released long ago are still present in the atmosphere.

## 11. Carbon Cycle

The level of carbon dioxide in the atmosphere is maintained by the carbon cycle.

Carbon dioxide is released through respiration, combustion of fuels and decay of organic material.

Respiration occurs in living things, and this involves breaking down glucose to obtain energy, carbon dioxide and water.

glucose + oxygen → carbon dioxide + water + energy



At the same time, carbon dioxide is removed from the atmosphere by photosynthesis. This occurs in plants and involves converting carbon dioxide and water into glucose and oxygen in the presence of sunlight.

carbon dioxide + water → glucose + oxygen

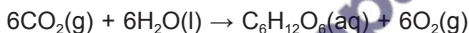

## 12. Global Warming

The Earth is kept warm through the greenhouse effect, which is caused by the trapping of heat energy from sunlight by greenhouse gases. Examples of such greenhouse gases are carbon dioxide, methane and water vapour.

Excessive amounts of greenhouse gases result in a stronger greenhouse effect, which leads to global warming. Global warming refers to the increase in global temperatures due to the accumulation of greenhouse gases in the atmosphere.

When greenhouse gases are produced faster than the rate at which they are removed from the atmosphere, an accumulation of these gases result in global warming. Global warming refers to an increase in global temperatures due to high levels of greenhouse gases.

Measures are taken to prevent adding on to the existing amount of greenhouse gases in the atmosphere. The burning of fossil fuels for energy is reduced to reduce emissions of carbon dioxide.

# TOPIC 20

## Introduction to Organic Chemistry

### Objectives

**Candidates should be able to:**

- (a) name natural gas, mainly methane, and petroleum as sources of energy
- (b) describe petroleum as a mixture of hydrocarbons and its separation into useful fractions by fractional distillation
- (c) name the following fractions and state their uses
  - (i) petrol (gasoline) as a fuel in cars
  - (ii) naphtha as the feedstock and main source of hydrocarbons used for the production of a wide range of organic compounds in the petrochemical industry
  - (iii) paraffin (kerosene) as a fuel for heating and cooking and for aircraft engines
  - (iv) diesel as a fuel for diesel engines
  - (v) lubricating oils as lubricants and as a source of polishes and waxes
  - (vi) bitumen for making road surfaces
- (d) describe the issues relating to the competing uses of oil as an energy source and as a chemical feedstock

### 1. Homologous Series

A homologous series of organic compounds have similar chemical properties as they share the same functional group. The chemical formula of a series can be described with a general formula.

There is a gradual change in the physical properties of the members as we move down a homologous series.

### 2. Naming Organic Compounds

The prefix of the name of an organic compound gives the number of carbon atoms present in the compound.

Number of carbon atoms	Prefix
1	Meth-
2	Eth-
3	Prop-
4	But-

The suffix of the name of an organic compound tells us which homologous series the compound belongs to.

Homologous series	Suffix
Alkanes	-ane
Alkenes	-ene
Alcohols	-ol
Carboxylic acids	-oic acid

### 3. Isomers

Isomers are compounds which have the same chemical formula but different structural formulae. They could belong to different homologous series. They usually share the same chemical properties but differ in physical properties.

### 4. Fractional Distillation of Petroleum

Petroleum is a mixture of hydrocarbons which can be separated into various useful fractions through fractional distillation.

Petroleum is first passed through a furnace to be heated into a vapour. The vapour is then passed through the fractionating column. Since petroleum consists of hydrocarbons of different sizes, the fractions have different boiling points and condense at different temperatures.

The vapour rises up the column where they will condense and be tapped off. Higher parts of the column have lower temperatures while lower parts of the column have higher temperatures.

Since lighter fractions have lower boiling points, they are tapped off at higher parts of the column. Heavier fractions on the other hand, have higher boiling points and are tapped off at lower parts of the column.

A simplified diagram of the fractional distillation of petroleum and the fractions collected is shown.

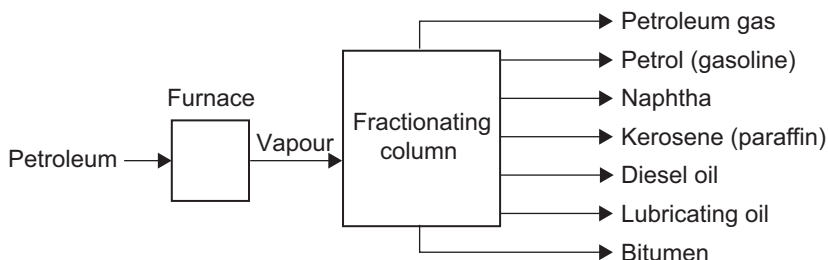

## 5. Fractions of Petroleum and Their Uses

Fraction	Boiling point range (°C)	Uses
Petroleum gas	Below 40	Fuel for domestic use (cooking, heating)
Petrol (gasoline)	40 to 75	Fuel for cars
Naphtha	90 to 150	Feedstock for chemical industries
Kerosene (paraffin)	150 to 240	Fuel for aircraft engines; Fuel for cooking and heating
Diesel oil	220 to 250	Fuel for heavy vehicles
Lubricating oil	300 to 350	For lubricating machine parts; Making waxes and polishes
Bitumen	Above 350	For road surfaces; Roofing

As smaller fractions can be used as fuel and chemical feedstock, the demand for smaller fractions is generally higher than that of larger fractions such as bitumen. To meet these demands, larger fractions are cracked to form smaller hydrocarbon molecules.



# TOPIC 21

## Alkanes and Alkenes

### Objectives

#### Candidates should be able to:

- describe an homologous series as a group of compounds with a general formula, similar chemical properties and showing a gradation in physical properties as a result of increase in the size and mass of the molecules, e.g. melting and boiling points; viscosity; flammability
- describe the alkanes as an homologous series of saturated hydrocarbons with the general formula  $C_nH_{2n+2}$
- draw the structures of branched and unbranched alkanes,  $C_1$  to  $C_4$ , and name the unbranched alkanes methane to butane
- define *isomerism* and identify isomers
- describe the properties of alkanes (exemplified by methane) as being generally unreactive except in terms of combustion and substitution by chlorine
- describe the alkenes as an homologous series of unsaturated hydrocarbons with the general formula  $C_nH_{2n}$
- draw the structures of branched and unbranched alkenes,  $C_2$  to  $C_4$ , and name the unbranched alkenes ethene to butene
- describe the manufacture of alkenes and hydrogen by cracking hydrocarbons and recognise that cracking is essential to match the demand for fractions containing smaller molecules from the refinery process
- describe the difference between saturated and unsaturated hydrocarbons from their molecular structures and by using aqueous bromine
- describe the properties of alkenes (exemplified by ethene) in terms of combustion, polymerisation and the addition reactions with bromine, steam and hydrogen
- state the meaning of *polyunsaturated* when applied to food products
- describe the manufacture of margarine by the addition of hydrogen to unsaturated vegetable oils to form a solid product

### 1. Alkanes

Alkanes are saturated hydrocarbons with the general formula  $C_nH_{2n+2}$ , where  $n \geq 1$ . Names of alkanes usually end with '-ane'. The first four members of the alkane homologous series are listed in the following table.

Name	Methane	Ethane	Propane	Butane
n	1	2	3	4
Molecular formula	$CH_4$	$C_2H_6$	$C_3H_8$	$C_4H_{10}$

Moving down the series, the molecular size of the alkanes increases. This means that the intermolecular forces of attraction become stronger. This leads to an increase in melting and boiling points and an increase in viscosity down the series. The flammability however decreases with an increase in molecular size of the alkanes.

## 2. Chemical Properties of Alkanes

Alkanes are generally unreactive as C – C and C – H bonds are not easily broken. They can only undergo combustion and substitution reactions.

Combustion occurs when an alkane combines with oxygen. The reaction is exothermic and hence, alkanes are used as fuels and are burned for energy.

If the alkane burns in excess oxygen, complete combustion occurs to produce carbon dioxide and water only. If the alkane burns under oxygen-deficient conditions, soot (carbon) and carbon monoxide are produced as well.

Alkanes can only react with halogens through substitution reactions. This occurs in the presence of ultraviolet light. Hydrogen atoms are substituted by halogen atoms in the reaction. The reaction produces a mixture of halogen-containing compounds.

## 3. Alkenes

Alkenes are unsaturated compounds with the general formula  $C_nH_{2n}$ , where  $n \geq 2$ . Note that a 1-carbon alkene cannot exist.

Names of alkenes usually end with '-ene'. The first three members of the alkene homologous series are listed in the following table.

Name	Ethene	Propene	Butene
n	2	3	4
Molecular formula	$C_2H_4$	$C_3H_6$	$C_4H_8$

## 4. Chemical Properties of Alkenes

Like alkanes, alkenes undergo complete combustion when there is sufficient oxygen to form carbon dioxide and water only. They undergo incomplete combustion to produce soot and carbon monoxide.

Due to the higher carbon-to-hydrogen ratio, alkenes burn with a smokier flame than their corresponding alkanes.

Alkenes are called unsaturated compounds due to the presence of C = C bonds. These bonds allow for alkenes to undergo addition reactions, which is a characteristic of alkenes.

Hydrogen gas can be added to an alkene to obtain an alkane. This reaction occurs at 200 °C in the presence of nickel as a catalyst.

ethene + hydrogen → ethane

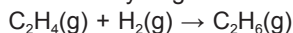

Margarine is produced by adding hydrogen to vegetable oils. Vegetable oil contains many C = C bonds, hence it is described to be polyunsaturated. One hydrogen molecule is added across each C = C bond in this process.

Halogens can be added across the C = C bond at room temperature and pressure to produce halogenoalkanes. An example is the addition of bromine to an alkene.

ethene + bromine → dibromoethane

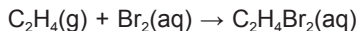

The addition of bromine is used in testing for the presence of unsaturated compounds. Aqueous bromine is reddish-brown and becomes colourless when an unsaturated compound is added.

Alcohols can be produced from the addition of steam to alkenes. This takes place at a temperature of 300 °C and pressure of 60 atm, in the presence of phosphoric(V) acid, which acts as a catalyst.

ethene + steam → ethanol

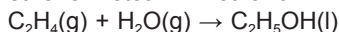

Alkene molecules can also react with one another to form a large saturated molecule through addition polymerisation. This process takes place at high temperature and pressure in the presence of a catalyst.

ethene → poly(ethene)

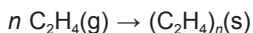

## 5. Cracking

Large hydrocarbons can be broken down into smaller molecules through cracking. This process requires aluminium oxide or silicon dioxide as catalyst.

The mixture of large hydrocarbons is passed over the catalyst at a high temperature of about 600 °C. These molecules are then broken down into a mixture of small alkanes and alkenes, and hydrogen is sometimes produced as well.

Small hydrocarbon molecules such as ethene are required as starting materials for petrochemical industries. Cracking is important as it converts larger fractions of petroleum, which are of lower demand, into small hydrocarbons which are in high demand.

In addition, cracking provides the source of hydrogen for the production of ammonia in the Haber process.

# TOPIC 22

## Alcohols and Carboxylic Acids

### Objectives

#### Candidates should be able to:

- describe the alcohols as an homologous series containing the  $-\text{OH}$  group
- draw the structures of alcohols,  $\text{C}_1$  to  $\text{C}_4$ , and name the unbranched alcohols methanol to butanol
- describe the properties of alcohols in terms of combustion and oxidation to carboxylic acids
- describe the formation of ethanol by the catalysed addition of steam to ethene and by fermentation of glucose
- state some uses of ethanol
- describe the carboxylic acids as an homologous series containing the  $-\text{CO}_2\text{H}$  group
- draw the structures of carboxylic acids methanoic acid to butanoic acid and name the unbranched acids, methanoic acid to butanoic acid
- describe the carboxylic acids as weak acids, reacting with carbonates, bases and some metals
- describe the formation of ethanoic acid by the oxidation of ethanol by atmospheric oxygen or acidified potassium manganate(VII)
- describe the reaction of a carboxylic acid with an alcohol to form an ester
- state some commercial uses of esters

### 1. Alcohols

Alcohols are a homologous series of organic compounds that have the general formula  $\text{C}_n\text{H}_{2n+1}\text{OH}$ , where  $n \geq 1$ . They have the functional group  $-\text{OH}$ , which is also called the hydroxyl group.

Names of alcohols usually end with '-ol'. The first four members of the alcohol homologous series are listed in the following table.

Name	Methanol	Ethanol	Propanol	Butanol
n	1	2	3	4
Molecular formula	$\text{CH}_3\text{OH}$	$\text{C}_2\text{H}_5\text{OH}$	$\text{C}_3\text{H}_7\text{OH}$	$\text{C}_4\text{H}_9\text{OH}$

Alcohols are liquids at room temperature and pressure and are very volatile. As the molecular sizes of the alcohols increases down the series, the forces of attraction between the molecules become stronger. As a result, the melting and boiling points increase with larger molecular size.

Smaller alcohols are miscible in water. As the molecular size of the alcohols increases, solubility in water decreases.

An important member of the homologous series is ethanol, which is used in food and drinks, as a solvent for paints and perfumes, and as fuel.



## 2. Chemical Properties of Alcohols

Alcohols undergo complete combustion when there is sufficient oxygen to produce carbon dioxide and water.

When heated with oxidising agents such as acidified potassium manganate(VII), alcohols undergo oxidation to form carboxylic acids.

## 3. Production of Ethanol

Ethanol used for human consumption is usually produced through fermentation of glucose from fruits or grains. The process is carried out with yeast at 37 °C, in the absence of oxygen.

The temperature has to be kept at 37 °C as the enzymes in yeast work best at this temperature. Increasing the temperature would denature the enzymes and cause them to be unable to catalyse the reaction.

Fermentation produces a dilute solution of ethanol. High concentrations of ethanol cannot be obtained directly from this process as the yeast dies when the concentration of ethanol reaches about 15%.

Ethanol is also produced on a larger scale through the addition of steam to ethene. This takes place at 300 °C and 60 atm in the presence of phosphoric(V) acid as a catalyst. This process produces an ethanol solution of higher purity and concentration compared to fermentation.

## 4. Carboxylic Acids

Alcohols are a homologous series of organic acids that have the general formula  $C_nH_{2n+1}COOH$ , where  $n \geq 0$ . They have the functional group  $-COOH$ , which is also called the carboxyl group.

Names of carboxylic acids usually end with '-oic acid'. The first four members of the carboxylic acid homologous series are listed in the following table.

Name	Methanoic acid	Ethanoic acid	Propanoic acid	Butanoic acid
n	0	1	2	3
Molecular formula	HCOOH	CH <sub>3</sub> COOH	C <sub>2</sub> H <sub>5</sub> COOH	C <sub>3</sub> H <sub>7</sub> COOH

## 5. Chemical Properties of Carboxylic Acids

Carboxylic acids are weak acids that partially dissociate in water to give hydrogen ions. Due to the presence of these hydrogen ions when carboxylic acids dissolve in water, they undergo reactions of acids.

Carboxylic acids react with metals that lie above hydrogen in the reactivity series to produce salt and water.

ethanoic acid + magnesium  $\rightarrow$  magnesium ethanoate + hydrogen  
 $2\text{CH}_3\text{COOH}(\text{aq}) + \text{Mg}(\text{s}) \rightarrow (\text{CH}_3\text{COO})_2\text{Mg}(\text{aq}) + \text{H}_2(\text{g})$

Carboxylic acids react with metal carbonates to produce salt, carbon dioxide and water.

ethanoic acid + calcium carbonate  $\rightarrow$  calcium ethanoate + carbon dioxide + water  
 $2\text{CH}_3\text{COOH}(\text{aq}) + \text{CaCO}_3(\text{s}) \rightarrow (\text{CH}_3\text{COO})_2\text{Ca}(\text{aq}) + \text{CO}_2(\text{g}) + \text{H}_2\text{O}(\text{l})$

Carboxylic acids react with metal hydroxides to produce salt and water.

ethanoic acid + sodium hydroxide  $\rightarrow$  sodium ethanoate + water  
 $\text{CH}_3\text{COOH}(\text{aq}) + \text{NaOH}(\text{aq}) \rightarrow \text{CH}_3\text{COONa}(\text{aq}) + \text{H}_2\text{O}(\text{l})$

## 6. Esters

Esters are sweet-smelling liquids that are used as solvents for perfumes or for making artificial food flavourings. They can be produced through esterification from the reaction between alcohols and carboxylic acids.

Esterification requires heating an alcohol and a carboxylic acid with a few drops of concentrated sulfuric acid as a catalyst. This process is a reversible reaction as indicated by the  $\rightleftharpoons$  symbol.

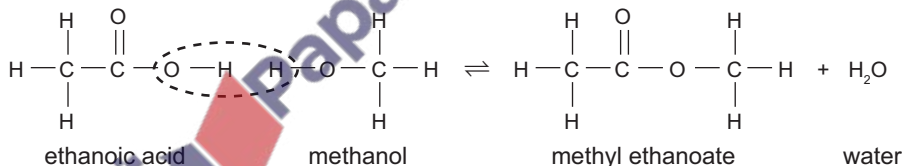

Apart from acting as a catalyst in the reaction, concentrated sulfuric acid is a dehydrating agent and removes water produced. This also helps speeding up the rate of product formation.

Note that there are two parts to the name of an ester. The first part of the name is taken from the alcohol while the second part is taken from the carboxylic acid from which it is made.

Objectives

Candidates should be able to:

- describe macromolecules as large molecules built up from small units, different macromolecules having different units and/or different linkages
- describe the formation of poly(ethene) as an example of addition polymerisation of ethene as the monomer
- state some uses of poly(ethene) as a typical plastic
- deduce the structure of the polymer product from a given monomer and vice versa
- describe nylon, a polyamide, and *Terylene*, a polyester, as condensation polymers, the partial structure of nylon being represented as

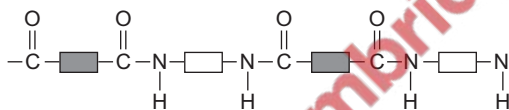

and the partial structure of *Terylene* as

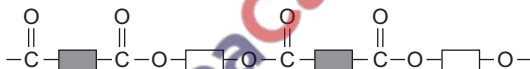

- state some typical uses of man-made fibres such as nylon and *Terylene*
- describe the pollution problems caused by the disposal of non-biodegradable plastics

## 1. Polymers

A polymer is a very large molecule that consists of many smaller molecules joined together by covalent bonds. These smaller units that make up the polymer are also called monomers.

## 2. Addition Polymerisation

Addition polymerisation occurs for unsaturated monomers. The reaction takes place under high temperature and pressure in the presence of a catalyst.

The process involves breaking the C = C bond so that the monomers can form bonds with other monomers. No atom or molecule is lost in this process, so the empirical formula of the addition polymer is the same as its monomer.

Poly(ethene) is produced through the addition polymerisation of ethene. It is used in making plastic bags and clingfilm.

### 3. Condensation Polymerisation

Condensation polymerisation involves joining of monomers with the loss of a small molecule for each linkage formed.

Nylon is a polyamide that has monomers joined together by amide linkages. It is formed from dicarboxylic acids and diamines. The formation of an amide linkage between the carboxyl and amine groups results in the loss of a water molecule.

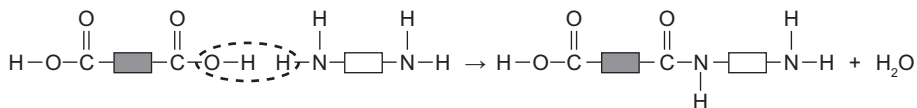

*Terylene* is a polyester that has monomers joined together by ester linkages. It is formed from dicarboxylic acids and diols. The formation of an ester linkage between the carboxyl and hydroxyl groups results in the loss of a water molecule.

Nylon and *Terylene* are both used to make clothing, curtains, fishing lines, parachutes and sleeping bags.

