



Moles and Stoichiometry

Theory Questions

Moles and Stoichiometry

Contents

MASS and MOLES.....	3
CONCENTRATION and MOLES	10
VOLUME OF GAS	18
LIMITING and EXCESS REACTANTS.....	24
PERCENTAGE YIELD	32
PERCENTAGE COMPOSITION	35
EMPIRICAL FORMULA	39
PERCENTAGE PURITY	44

MASS and MOLES

Question 1.

- (d) Cement is made by heating calcium carbonate and clay together at a very high temperature.

One of the compounds produced is a form of calcium silicate, Ca_3SiO_5 .

In the presence of water a chemical reaction takes place that helps in the setting of cement.

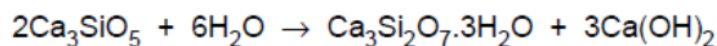

Calculate the mass of calcium hydroxide formed from 912 g of Ca_3SiO_5 .

.....

.....

.....

.....

.....

..... [3]

s/06/qp2

Question 2.

- (c) Potassium sulphate can be prepared by the reaction between dilute sulphuric acid and potassium carbonate.

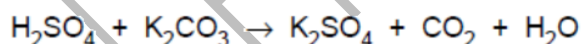

Calculate the mass of potassium sulphate that can be prepared from 3.45 g of potassium carbonate. [3]

s/06/qp2

Question 3.

- B9** Hydrogen and iodine react together to form hydrogen iodide in a reversible redox reaction. The forward reaction is endothermic.

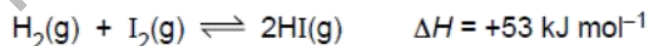

Hydrogen and hydrogen iodide are colourless gases whereas iodine gas is purple.

Moles and Stoichiometry

- (c) Calculate the maximum mass of hydrogen iodide that can be made from 45.3g of hydrogen.

maximum mass of hydrogen iodide = g [3]

s/10/qp22

Question 4.

- (b) Octane burns in air.

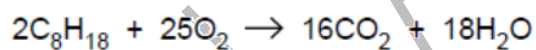

A petrol-powered motor car travels at a constant speed of 80 km/h. For every kilometre travelled 108 g of carbon dioxide are formed.

When the motor car travels 100 km calculate

- (i) the mass of carbon dioxide emitted by the car,

[1]

- (ii) the mass of petrol burned by the car assuming that petrol is 100% octane.

[4]

s/09/qp2

Question 5.

Moles and Stoichiometry

(iv) Calculate the mass of uranium that can be made from 1.00 tonne of uranium(IV) oxide.

[One tonne is one million grams.]

mass of uranium = tonnes [3]

s/11/qp21

Question 6.

B7 Nitric oxide, NO, is an atmospheric pollutant formed inside car engines by the reaction between nitrogen and oxygen.

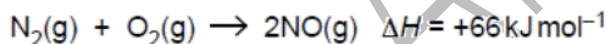

This reaction is endothermic.

(c) Calculate the mass of nitric oxide formed when 100 g of nitrogen reacts completely with oxygen.

mass of nitric oxide = g [3]

s/11/qp22

Question 7.

Moles and Stoichiometry

(c) Fermentation converts glucose into ethanol, a biofuel.

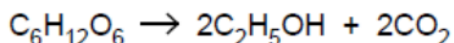

(i) State two essential conditions for fermentation to take place.

1

2 [2]

(ii) Calculate the maximum mass of ethanol that can be made from 1 tonne of glucose.

[One tonne is one million grams.]

maximum mass of ethanol = tonne [3]

s/11/qp22

Question 8.

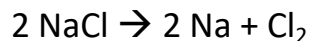

(b) Chlorine is manufactured by the electrolysis of concentrated sodium chloride.

(i) Write equations for both of the electrode reactions.

(ii) Calculate the maximum volume of chlorine, at r.t.p., which can be obtained from 175.5 kg sodium chloride.

[5]

w/01/qp2

Question 9.

(b) Ammonium sulphate can be made by reacting aqueous ammonia with dilute sulphuric acid.

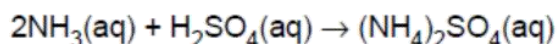

Calculate the mass of ammonium sulphate that can be made from 51 g ammonia.

.....

.....

..... [3]

w/04/qp2

Question 10.

Moles and Stoichiometry

- (d) Methylamine is made by reacting methanol with excess ammonia under pressure in the presence of a catalyst.

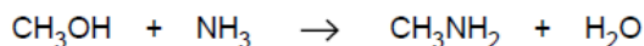

- (i) Define the term *catalyst*.

.....[1]

- (ii) Calculate the theoretical yield of methylamine that can be obtained from 240 kg of methanol.

[2]

w/08/qp2

Question 11.

- (e) Solid zinc chloride absorbs ammonia to form tetrammine zinc chloride, $\text{Zn}(\text{NH}_3)_4\text{Cl}_2$.

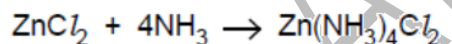

Calculate the maximum yield, in grams, of tetrammine zinc chloride formed when 3.4 g of zinc chloride reacts with excess ammonia.

[2]

w/10/qp22

Question 12.

Moles and Stoichiometry

- (e) Molybdenum, atomic number 42, is manufactured by the displacement reaction between molybdenum(VI) oxide and aluminium.

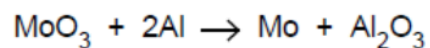

Calculate the mass of aluminium needed to make 1 tonne of molybdenum.
[1 tonne is one million grams.]

mass of aluminium = [2]

s/12/qp21

Fahad H. Ahmad

Moles and Heat Energy

Question 13.

B9 Hydrogen has many industrial uses. One possible way to manufacture hydrogen involves the reversible reaction between methane and steam.

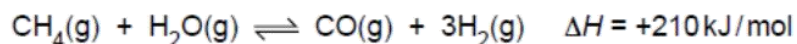

The reaction is carried out in the presence of a nickel catalyst. The conditions used are 30 atmospheres pressure and a temperature of 750 °C.

(d) In the reaction, 210 kJ of heat energy is used to form 3.0 moles of hydrogen.

Calculate how much heat energy is needed to make 1000 kg of hydrogen.

heat energy = kJ [2]

s/12/qp21

Question 14.

B9 Methanol, CH₃OH, is manufactured from carbon dioxide and hydrogen.

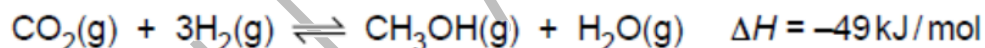

(c) In the reaction when 3.0 moles of hydrogen react, 49 kJ of heat energy is released.

Calculate how much heat energy is released when 500 kg of hydrogen react.

heat energy = kJ [2]

w/12/qp22

CONCENTRATION and MOLES

Question 15.

- (d) The mass of iron(II) ions in a sample of fertiliser can be determined by the reaction between iron(II) ions and acidified potassium manganate(VII), KMnO_4 .

A student analysed a sample of the fertiliser. He dissolved the sample in 25.0 cm^3 of dilute sulphuric acid and titrated the solution formed with 0.0200 mol/dm^3 potassium manganate(VII).

The student used 22.5 cm^3 of potassium manganate(VII) to reach the end-point.

- (i) Calculate the number of moles of potassium manganate(VII) used in the titration.

..... moles [1]

- (ii) One mole of potassium manganate(VII) reacts with five moles of iron(II) ions. Calculate the mass, in grams, of iron(II) ions in the sample analysed.

..... g [2]

[Total: 9]

Moles and Stoichiometry

(e) An impure sample of iron(II) sulphate was analysed by titration.

The sample was dissolved in 25.0 cm^3 of dilute sulphuric acid and then titrated against 0.0400 mol/dm^3 potassium dichromate(VI) solution.

19.0 cm^3 of potassium dichromate(VI) solution was required to reach the end-point.

(i) Calculate the number of moles of potassium dichromate(VI) used in the titration.

..... moles [1]

(ii) One mole of potassium dichromate(VI) reacts with six moles of iron(II) ions. Calculate the mass, in grams, of iron(II) ions in the sample analysed.

mass of iron(II) ions..... g [2]

[Total: 11]

s/08/qp2

Question 16.

Sulfamic Acid = SO_3NH_2

(c) A 0.105 g sample of sulfamic acid is dissolved in 25.0 cm^3 of water. The sulfamic acid solution requires 10.8 cm^3 of 0.100 mol/dm^3 potassium hydroxide for complete neutralisation.

Calculate the number of moles of sulfamic acid that react with one mole of potassium hydroxide.

number of moles of sulfamic acid = [3]

s/11/qp21

Moles and Stoichiometry

Question 17.

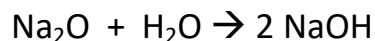

Sodium oxide reacts with water to form sodium hydroxide.

(b) Write an equation for this reaction.

.....[1]

(c) 62 g of sodium oxide are used to make 2 dm³ of aqueous sodium hydroxide.
What is the concentration of the sodium hydroxide solution?

Answer mol/dm³ [2]

w/03/qp2

Question 18.

(d) 12.0 cm³ of an aqueous solution of sulphuric acid exactly neutralised 20.0 cm³ of a solution of sodium hydroxide of concentration 0.150 mol/dm³.

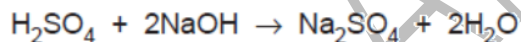

Calculate the concentration, in mol/dm³ of the aqueous sulphuric acid. [3]

w/06/qp2

Question 19.

(iii) 25.0 cm³ of an aqueous solution of calcium hydroxide is exactly neutralised by 18.0 cm³ of 0.040 mol/dm³ hydrochloric acid.



Calculate the concentration, in mol/dm³, of the aqueous calcium hydroxide.

concentration =mol/dm³ [3]

w/08/qp2

Question 20.

Moles and Stoichiometry

B6 Seawater contains many dissolved ions. The table shows the concentration of some of these ions in a typical sample of seawater.

ion	formula	concentration/ g/dm ³
chloride	Cl ⁻	19.00
sodium	Na ⁺	10.56
sulfate	SO ₄ ²⁻	2.65
magnesium	Mg ²⁺	1.26
calcium	Ca ²⁺	0.40
potassium	K ⁺	0.38
hydrogencarbonate	HCO ₃ ⁻	0.14

(a) Suggest the formula of one salt dissolved in seawater.

..... [1]

(b) Calculate the concentration, in mol/dm³, of sulfate ions in seawater.

.....
.....
..... [1]

s/12/qp21

Question 23.

(b) The student uses 25.0 cm³ of 1.60 mol/dm³ sodium hydroxide to prepare the crystals.

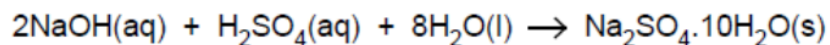

Calculate the maximum mass of hydrated sodium sulfate crystals that can be formed.

[4]

(c) When hydrated sodium sulfate crystals are heated gently, water is given off.

Describe a chemical test for water.

test

observation [2]

w/11/qp21

Question 24.

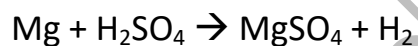

(ii) A student reacts 3.0 g of magnesium with 2.5 mol/dm³ sulfuric acid.
Calculate the minimum volume of sulfuric acid that reacts with all the magnesium.

[2]

w/11/qp22

Question 25.

- (c) Chlorine reacts with cold dilute sodium hydroxide to form sodium chlorate(I), NaClO, sodium chloride and water.
Construct an equation for this reaction.

[1]

- (d) The concentration of sodium chlorate(I) in a solution can be found by reacting sodium chlorate(I) with excess acidified potassium iodide and then titrating the iodine liberated with aqueous sodium thiosulfate, Na₂S₂O₃.

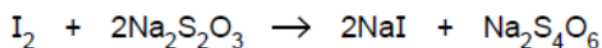

A solution of sodium thiosulfate contains 12.4 g of sodium thiosulfate, Na₂S₂O₃·5H₂O, in 1.00 dm³ of solution.

- (i) Calculate the concentration of the sodium thiosulfate solution in mol/dm³.

concentration = mol/dm³ [1]

- (ii) 23.6 cm³ of this sodium thiosulfate solution reacts with exactly 12.5 cm³ of aqueous iodine.
Calculate the concentration, in mol/dm³, of the aqueous iodine.

[3]

- (b) Nickel carbonyl has the formula Ni(CO)_x.
The relative molecular mass of nickel carbonyl is 171.
Calculate the value of x.

value of x = [1]

w/12/qp22

Question 26.

- (c) Sulfuric acid is formed from sulfur trioxide in two stages.
Firstly, the sulfur trioxide, SO_3 , is absorbed in concentrated sulfuric acid to form oleum, $\text{H}_2\text{S}_2\text{O}_7$.

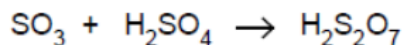

The oleum is then mixed with water to form sulfuric acid.
Construct an equation for this reaction.

[1]

- (d) Aqueous sulfuric acid is titrated with aqueous sodium hydroxide.

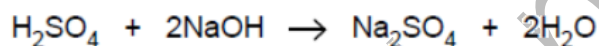

It requires 28.0 cm^3 of 0.100 mol/dm^3 aqueous sodium hydroxide to neutralise 9.50 cm^3 of sulfuric acid.

Calculate the concentration, in mol/dm^3 , of the aqueous sulfuric acid.
Give your answer to 3 significant figures.

concentration of the aqueous sulfuric acid mol/dm^3 [3]

w/12/qp21

VOLUME OF GAS

Question 27.

B7 Hydrazine, N_2H_4 , is a liquid that has been used as a rocket fuel. It reacts with oxygen as shown in the equation.

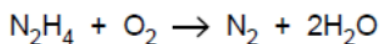

- (c) (i) Calculate the volume of oxygen, measured at room temperature and pressure, needed to completely combust 1.00 tonne of hydrazine.
[One tonne is 10^6 grams. One mole of any gas at room temperature and pressure occupies a volume of 24 dm^3 .]

volume of oxygen = dm^3 [3]

- (ii) A rocket burns hydrazine in an atmosphere of oxygen. Both hydrazine and oxygen are stored in the rocket as liquids. Suggest why oxygen is stored as a liquid rather than as a gas.

.....
..... [1]

s/10/qp22

Question 28.

Stage 2: the nitrogen dioxide is converted to nitric acid.

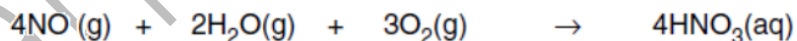

- (c) Calculate the maximum mass of nitric acid which can be made from 720 dm^3 of nitrogen(II) oxide, NO , at room temperature and pressure. [3]

w/02/qp2

Question 29.

Moles and Stoichiometry

1 mol MgCO_3 or ZnCO_3 produces 1 mol CO_2

- (b) Calculate the maximum volume of carbon dioxide, at room temperature and pressure, that can be formed from 10.5 g of magnesium carbonate. [3]
- (c) The experiment was repeated under the same conditions using zinc carbonate instead of magnesium carbonate.
- (i) Describe how the rates of the reactions would be different. Explain your answer.
- (ii) The same mass (10.5 g) of zinc carbonate was used. Would the total volume of carbon dioxide formed be the same? Explain your answer. [4]

w/04/qp2

Question 30.

- 5 An experiment was carried out to measure the rate of reaction between excess powdered calcium carbonate and dilute acids.
- (a) In **Experiment 1**, 25 cm^3 of 1.5 mol/dm^3 hydrochloric acid was used.
- Complete the equation for the reaction by filling in the missing state symbols.
- (i) $2\text{HCl}(\dots\dots\dots) + \text{CaCO}_3(\dots\dots\dots) \rightarrow \text{CaCl}_2(\text{aq}) + \text{H}_2\text{O}(\dots\dots\dots) + \text{CO}_2(\dots\dots\dots)$
- (ii) Calculate the total volume of carbon dioxide that is made from this reaction at r.t.p.

[4]

w/05/qp2

Question 31.

B9 Phosphine, PH_3 , is a gas which has a smell of garlic. It is formed when white phosphorus is warmed with aqueous sodium hydroxide.

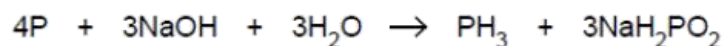

(a) Draw a 'dot-and-cross' diagram for phosphine.

Show only the outer electrons.

[1]

(b) (i) Calculate the maximum mass of phosphine formed when 1.86 g of phosphorus reacts with excess aqueous sodium hydroxide.

[2]

(ii) Calculate the volume of phosphine formed from 1.86 g of phosphorus at r.t.p.

[1]

(c) Phosphine decomposes into its elements on warming. Write an equation for this reaction.

..... [2]

w/10/qp21

Question 32.

(d) The overall reaction for the electrolysis of aqueous sodium hydroxide is shown below.

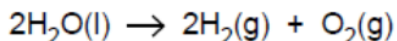

This reaction is endothermic.

(i) Explain, in terms of the energy changes associated with bond breaking and bond forming, why the reaction is endothermic.

.....
.....
.....
..... [2]

(ii) Some submarines use this reaction to provide oxygen for the occupants to breathe.

Calculate the mass of water which must be electrolysed to make 2500 dm³ of oxygen at room temperature and pressure.

[One mole of any gas at room temperature and pressure occupies a volume of 24 dm³.]

mass of water = g [3]

s/12/qp21

Question 33.



(c) A hydrogen-oxygen fuel cell uses 2000 dm³ of hydrogen measured at room temperature and pressure.

Calculate the volume of oxygen, measured at room temperature and pressure, used by the fuel cell.

[One mole of any gas at room temperature and pressure occupies a volume of 24 dm³.]

.....
.....
.....

volume of oxygen = dm³ [2]

w/12/qp22

Question 34.

B9 Hydrogen fluoride, hydrogen chloride and hydrogen iodide are all acidic gases.

- (a) A student makes hydrogen chloride by reacting sodium chloride with excess concentrated sulfuric acid at room temperature and pressure.

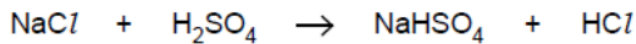

- (i) Calculate the maximum volume of hydrogen chloride that can be made from 0.2 moles of sodium chloride at room temperature and pressure.

- (ii) Draw a 'dot-and-cross' diagram for hydrogen chloride.
Show only the outer electrons.

[1]

[1]

w/11/qp21

Question 35.

- (d) A student ignites a mixture of 15 cm³ of propane and 100 cm³ of oxygen. The oxygen is in excess. All measurements of volume are taken at room temperature and pressure.

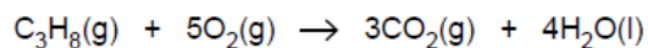

Calculate

the volume of carbon dioxide formed,

..... cm³ [1]

the volume of unreacted oxygen remaining.

..... cm³ [1]

- (e) Explain why the **incomplete** combustion of an alkane in an enclosed space is hazardous.

.....

..... [2]

w/11/qp22

Fahad H. Ahmad

LIMITING and EXCESS REACTANTS

Question 36.

Fahad H. Ahmad

Moles and Stoichiometry

A5 Marble statues are being damaged by acid rain. The chemical name for marble is calcium carbonate.

A student investigated the reaction between marble chips and nitric acid.

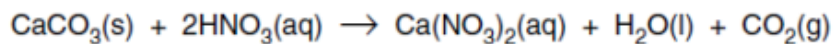

The diagram shows the apparatus the student used.

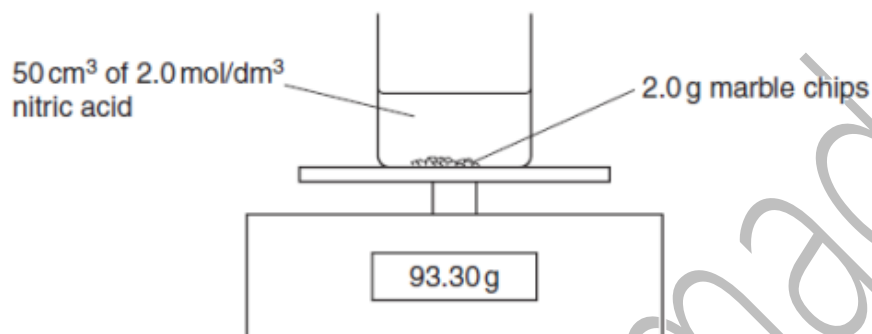

The student recorded the balance reading every minute.

The table shows the results.

time / minutes	balance reading / g
0	93.30
1	93.28
2	93.26
3	93.24
4	93.22
5	93.21
6	93.20
7	93.19
8	93.18
9	93.17
10	93.16
11	93.15
12	93.15
13	93.14
14	93.14

(a) Explain why the balance reading decreases during the experiment.

.....
.....[1]

(b) How can the student tell when the reaction has finished?

.....
.....[1]

(c) (i) Calculate the number of moles of nitric acid in 50 cm^3 of 2.0 mol/dm^3 solution.

(ii) Calculate the number of moles of calcium carbonate in 2.0 g .

(iii) Which reagent, calcium carbonate or nitric acid, is in excess?
Explain your answer.

[5]

(d) The student repeats the experiment using the same quantities of calcium carbonate and nitric acid. This time the acid is at a higher temperature. Describe and explain, in terms of collisions between reacting particles, the effect of increasing the temperature on the rate of reaction.

.....

.....

.....[2]

s/03/qp2

Question 37.

Moles and Stoichiometry

B9 Dilute ethanoic acid and dilute hydrochloric acid both react with magnesium ribbon to form hydrogen.

(a) Give the formula of one ion found in both of these dilute acids. [1]

(b) Magnesium ribbon reacts with hydrochloric acid as shown in the equation.

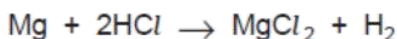

A 0.24 g sample of magnesium ribbon is added to 5.0 cm³ of 2.0 mol/dm³ hydrochloric acid.

(i) Which reactant, magnesium or hydrochloric acid, is in excess? Use calculations to explain your answer. [2]

(ii) Calculate the maximum mass of magnesium chloride that can be formed in this reaction. [2]

(iii) A 0.24 g sample of magnesium ribbon is added to 5.0 cm³ of 2.0 mol/dm³ ethanoic acid.

Explain why this reaction forms the same volume of hydrogen but takes place much more slowly than the reaction of the same mass of magnesium with 5.0 cm³ of 2.0 mol/dm³ hydrochloric acid. [3]

(c) (i) Write an equation for the reaction between dilute ethanoic acid and sodium carbonate. [1]

(ii) What observations would be made during this reaction? [1]

[Total: 10]

s/08/qp2

Question 38.

A3 Analysis of a compound **Z** obtained from the planet Mars showed **Z** has the following composition.

element	percentage by mass
potassium	39.4
iron	28.3
oxygen	32.3

(a) Show that the empirical formula of **Z** is K_2FeO_4 .

.....

.....

.....

.....

[2]

(b) K_2FeO_4 can be prepared in the laboratory by the reaction between iron(III) oxide, Fe_2O_3 , chlorine, Cl_2 , and potassium hydroxide, KOH.

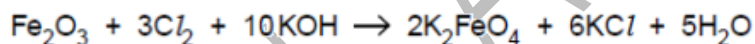

A 2.00 g sample of Fe_2O_3 is added to 20.0 cm³ of 4.00 mol dm⁻³ KOH.

(i) Calculate the amount, in moles, of Fe_2O_3 used.

.....

[2]

(ii) Calculate the amount, in moles, of KOH used.

.....

[1]

(iii) Which reagent, Fe_2O_3 or KOH, is in excess in this reaction?

Explain your answer.

.....

[1]

(c) Magnesium reacts with propanoic acid to form magnesium propanoate and hydrogen.



A student added 4.80 g of magnesium to 30.0 g of propanoic acid.

- (i) Which one of these reactants, magnesium or propanoic acid, is in excess?
Explain your answer. [2]
- (ii) Calculate both the number of moles of hydrogen and the volume of hydrogen formed at r.t.p. [2]

w/07/qp2

Question 40.

Fahad H. Ahmad

- A2** Several small pieces of magnesium are placed on a block of solid carbon dioxide. The solid carbon dioxide is at a temperature of -60°C . The magnesium is ignited and another block of solid carbon dioxide is immediately placed on top.

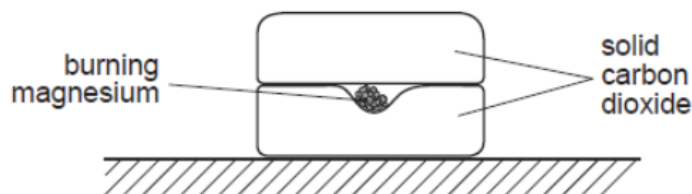

A vigorous reaction is observed.



- (a) Suggest what could be seen as the reaction proceeds to completion.

.....
..... [2]

- (b) Why is another block of solid carbon dioxide placed above the burning magnesium?

..... [1]

- (c) State one factor in the experiment which slows down the reaction.

..... [1]

- (d) When 2 moles of magnesium react with one mole of carbon dioxide, 810 kJ of energy are released.
Calculate the energy released when 2.0 g of magnesium reacts completely with carbon dioxide.

[2]

- (e) In a second experiment 6.0 g of magnesium and 4.4 g of carbon dioxide are used. Which solid, magnesium or carbon dioxide is in excess?
Show your working.

[2]

w/08/qp2

Fahad H. Ahmad

PERCENTAGE YIELD

Question 41.

(d) Ethanol can also be manufactured from glucose, $C_6H_{12}O_6$.

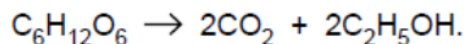

A solution containing 18 kg of glucose makes only 0.92 kg of ethanol.
Calculate the percentage yield of ethanol.

[3]

s/09/qp2

Question 42.

B8 One of the reactions in the manufacture of nitric acid involves the oxidation of ammonia. This reaction is exothermic.

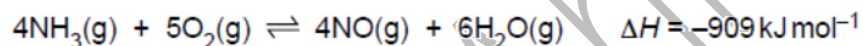

(b) A factory uses 100 tonnes of ammonia each day to produce 160 tonnes of nitrogen monoxide, NO.
Calculate the percentage yield of nitrogen monoxide.

percentage yield = % [3]

s/10/qp21

Question 43.

B8 Ethanoic acid is manufactured by a reaction between methanol, CH_3OH , and carbon monoxide.

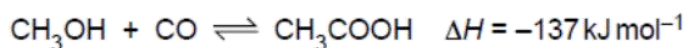

This reaction is exothermic.

Moles and Stoichiometry

- (d) In an investigation 10.0 moles of methanol are mixed with 20.0 moles of carbon monoxide.
At the end of the reaction 9.8 moles of ethanoic acid are formed.
Calculate the percentage yield of ethanoic acid.

percentage yield = % [2]

s/11/qp21

Question 44.

Fahad H. Ahmad

B9 (a) Define the term *relative atomic mass*.

.....
..... [1]

(b) The relative atomic mass of magnesium can be determined in the laboratory by finding the volume of hydrogen given off when magnesium reacts with hydrochloric acid.

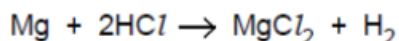

0.036 g of magnesium reacts at room temperature and pressure with excess hydrochloric acid to produce 36 cm³ of hydrogen.

1 mole of any gas at room temperature and pressure occupies 24 dm³.

Show by calculation that the relative atomic mass of magnesium is 24.

[3]

(c) Magnesium reacts with oxygen in the air to form magnesium oxide.



(i) If the yield of the reaction is 75% calculate the mass of magnesium oxide formed when 12 kg of magnesium burns in excess air.

[2]

(ii) Magnesium nitride is also formed when magnesium burns in air. Magnesium nitride is an ionic compound. Deduce the formula for magnesium nitride.

..... [1]

PERCENTAGE COMPOSITION

Question 45.

A2 Iron(II) sulphate, FeSO_4 , is easily oxidised to iron(III) sulphate.

- (a) Calculate the percentage by mass of iron in iron(II) sulphate.

..... % [2]

s/08/qp2

Question 46.

B10 The table below shows some of the ores of iron.

ore	formula
haematite	Fe_2O_3
magnetite	Fe_3O_4
siderite	FeCO_3

- (a) Which ore in the table contains the greatest percentage by mass of iron? Explain your answer. [2]

s/04/qp2

Question 47.

A2 A fertiliser contains three compounds:

- ammonium sulphate, $(\text{NH}_4)_2\text{SO}_4$,
- iron(II) sulphate, FeSO_4 ,
- sand, SiO_2 .

- (a) Calculate the percentage by mass of nitrogen in ammonium sulphate.

..... % [2]

s/07/qp2

Question 48.

Moles and Stoichiometry

- (c) Verdigris has the formula $[\text{Cu}(\text{CH}_3\text{CO}_2)_2]_2 \cdot \text{Cu}(\text{OH})_2 \cdot x\text{H}_2\text{O}$.
It has a relative formula mass of 552.
Calculate the value of x in the formula.

x is [2]

[Total: 5]

s/07/qp2

Question 49.

- (ii) Calculate the percentage by mass of nitrogen in ammonium phosphate.

% by mass = [2]

s/10/qp22

Question 50.

B10 Fertilisers supply the essential elements, nitrogen, phosphorus and potassium for plant growth.

A bag of fertiliser contains 500g of ammonium sulfate, $(\text{NH}_4)_2\text{SO}_4$, and 500g of potassium nitrate, KNO_3 .

- (a) Calculate the percentage by mass of nitrogen in the bag of fertiliser.

[4]

s/09/qp2

Question 51.

Moles and Stoichiometry

- (d) Farmers that grow vegetable oil crops often use large quantities of ammonium nitrate fertiliser, NH_4NO_3 .
Calculate the percentage by mass of nitrogen in ammonium nitrate.

percentage = % [2]

s/11/qp22

Question 52.

- (iii) Calculate the percentage of copper by mass in Cu_2O .

[5]

w/05/qp2

Question 53.

- (d) Fertilisers are added to the soil to improve crop yields.
A farmer has the choice of two fertilisers, ammonium nitrate, NH_4NO_3 , or diammonium hydrogen phosphate, $(\text{NH}_4)_2\text{HPO}_4$.

Show by calculation which of these fertilisers contains the greater percentage of nitrogen by mass.

You must show your working.

[3]

w/06/qp2

Question 54.

- (ii) Another compound of bromine and fluorine is bromine(V) fluoride, BrF_5 .
Calculate the percentage of bromine by mass in bromine(V) fluoride.

[2]

w/11/qp22

Question 55.

(c) Ammonium nitrate, NH_4NO_3 , and ammonium sulfate, $(\text{NH}_4)_2\text{SO}_4$, are commonly used in fertilisers.

(i) Calculate the percentage of nitrogen by mass in ammonium nitrate.

[3]

w/12/qp22

Fahad H. Ahmad

EMPIRICAL FORMULA

Question 56.

- (c) Analysis of an organic acid isolated from red ants shows that it contains 0.060 g of carbon, 0.010 g of hydrogen and 0.16 g of oxygen.
Calculate the empirical formula for this acid. [2]

s/03/qp2

Question 57.

- (c) Ethene can also be converted into a compound that contains carbon, hydrogen and oxygen. A sample of the compound was analysed and found to contain 0.72 g of carbon, 0.18 g of hydrogen and 0.96 g of oxygen.
Show that the empirical formula of the compound is CH_3O . [3]

s/04/qp2

Question 58.

- (e) A sample of a compound of iron is analysed. The sample contains 0.547 g of potassium, 0.195 g of iron, 0.252 g of carbon and 0.294 g of nitrogen.
Calculate the empirical formula of this compound.

Answer[3]

s/05/qp2

Question 59.

B8 An ester is made from a carboxylic acid and an alcohol.

The carboxylic acid has the molecular formula $\text{C}_4\text{H}_8\text{O}_2$. Analysis of the alcohol shows it has the following percentage composition by mass:
52.2% carbon; 13.0% hydrogen; 34.8% oxygen.

(iii) What is the empirical formula for the carboxylic acid?

..... [1]

(b) Calculate the empirical formula for the alcohol.

.....
.....
.....
.....
..... [2]

s/10/qp2

Question 60.

A2 Small pieces of copper were added to excess concentrated sulfuric acid and the mixture heated for 30 minutes. A colourless gas **Z** was formed. When **Z** was tested with filter paper dipped into acidified potassium dichromate(VI), there was a colour change from orange to green.

The reaction mixture was cooled and then diluted with water. A blue solution, **Y**, was formed. Aqueous sodium hydroxide was added drop by drop to the blue solution. Eventually a blue precipitate, **X**, was formed. On heating the blue precipitate turned black to form compound **V**. Analysis of **V** showed that it contained 79.9 % copper and 20.1 % oxygen by mass.

(e) Calculate the empirical formula of the black solid **V**.

empirical formula of **V** is [2]

s/11/qp21

Question 61.

(c) Butanoic acid can be converted into an ester by heating it with an alcohol and a few drops of concentrated sulphuric acid.

A sample of an ester contains 0.18 g of carbon, 0.03 g of hydrogen and 0.08 g of oxygen. The relative molecular mass of the ester is 116.

Calculate both the empirical and molecular formulae of this ester. [3]

w/06/qp2

Question 62.

Moles and Stoichiometry

- (c) Carbon monoxide reacts with nickel to form a compound containing nickel, carbon and oxygen only. Analysis of 5.70 g of this compound showed that it contained 1.97 g nickel, 1.60 g carbon and 2.13 g oxygen.
Determine the empirical formula of this compound. [3]

w/07/qp2

Question 63.

- (c) Analysis of 10.0 g of carboxylic acid X shows that it contains 2.67 g carbon, 0.220 g hydrogen and 7.11 g oxygen.
- (i) Deduce the empirical formula of X. [3]
- (ii) The relative molecular mass of X is 90. Deduce the molecular formula of X. [1]

w/08/qp2

Question 64.

- (d) A small amount of xenon is present in the air. Several compounds of xenon have been made in recent years.
A compound of xenon contained 9.825 g of xenon, 1.200 g of oxygen and 5.700 g of fluorine.
Determine the empirical formula of this compound.

[3]

w/08/qp2

Question 65.

- (b) Analysis of 21.25 g of gallic acid showed that it contained 10.50 g of carbon, 0.75 g of hydrogen and 10.00 g of oxygen.

Show that the empirical formula of gallic acid is $C_7H_6O_5$.

[3]

w/10/qp21

Question 66.

- (c) Carboxylic acid X contains 55.8% carbon, 7.0% hydrogen and 37.2% oxygen.

(i) Calculate the empirical formula of X.

[2]

- (ii) A molecule of carboxylic acid X contains four carbon atoms. What is its molecular formula?

..... [1]

- (iii) Carboxylic acid X is an unsaturated compound.
Give a test for an unsaturated compound.

test

observation [2]

[Total: 10]

w/11/qp22

Question 67.

- (iii) The composition by mass of ethanal is C 54.5%, H 9.1%, O 36.4%.
Calculate the empirical formula of ethanal.

[2]

w/12/qp22

Fahad H. Ahmad

PERCENTAGE PURITY

Question 68.

- (b) Tartaric acid can also be extracted from grape juice.
The structure of tartaric acid is shown below.

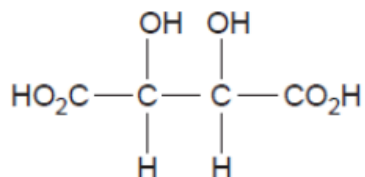

- (i) Deduce the empirical formula of tartaric acid.

.....[1]

- (ii) A solution of tartaric acid was titrated with 0.100 mol/dm³ potassium hydroxide.

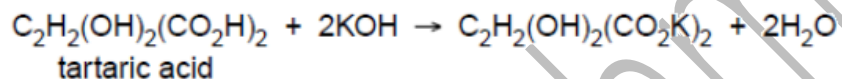

It required 6.00 cm³ of the potassium hydroxide solution to neutralise 20.0 cm³ of tartaric acid. Calculate the concentration, in mol/dm³, of the tartaric acid solution.

.....mol/dm³ [3]

- (iii) Tartaric acid is purified by recrystallisation.

On analysis, 8.00g of impure tartaric acid was found to contain 7.40g of pure tartaric acid. Calculate the percentage purity of the impure tartaric acid.

.....% [1]