



UNIVERSITY OF CAMBRIDGE INTERNATIONAL EXAMINATIONS
International General Certificate of Secondary Education

CANDIDATE
NAME

CENTRE
NUMBER

--	--	--	--	--

CANDIDATE
NUMBER

--	--	--	--

* 3 1 1 4 3 8 0 4 3 5 *

DESIGN AND TECHNOLOGY

0445/04

Paper 4 Systems and Control

May/June 2008

1 hour

Candidates answer on the Question Paper.

No Additional Materials are required.

To be taken together with Paper 1 in one session of 2 hours and 15 minutes.

READ THESE INSTRUCTIONS FIRST

Write your Centre number, candidate number and name on all the work you hand in.

Write in dark blue or black pen.

You may use a soft pencil for any diagrams or graphs.

Do not use staples, paper clips, highlighters, glue or correction fluid.

DO NOT WRITE IN ANY BARCODES.

You may use a calculator.

Section A

Answer **all** questions.

Section B

Answer **one** question.

At the end of the examination, fasten all your work securely together.

The number of marks is given in brackets [] at the end of each question or part question.

For Examiner's Use	
Section A	
Section B	
Total	

This document consists of an **14** printed pages and **2** blank pages.



Section A

Answer all questions in this section.

1 State the force acting on a tie in a framed structure.

..... [1]

2 (a) Name the transducer used to sense a change in light.

..... [1]

(b) Give one example of the use of a light sensor.

..... [1]

3 An eccentric cam driven by an electric motor is used to control the motion of a follower.

Complete the block diagram below to show the motion conversions that take place.

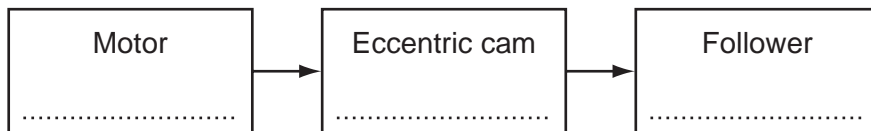

[3]

4 Sketch and label the circuit symbol for a transistor.

[3]

5 (a) Name the order of the lever shown below.

..... [1]

(b) Add labels to the diagram below to show:

- effort;
- load;
- fulcrum.

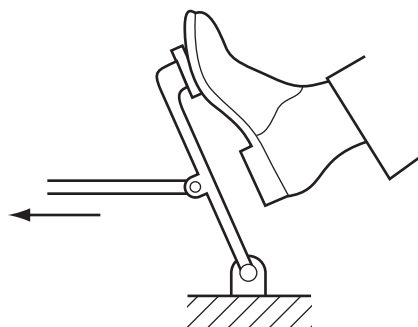

[3]

6 Complete the statement below.

Movement energy is called energy.

7 When a simple battery-powered vehicle, as shown below, is operated, energy is converted into different forms. Some forms of energy are considered energy losses.

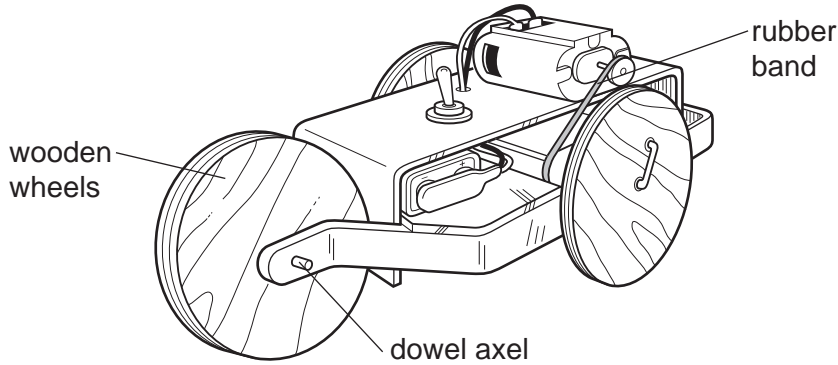

(a) Give **two** energy losses for the vehicle.

1 [1]

2 [1]

(b) (i) Give **two** ways of improving the energy efficiency of the vehicle.

1 [1]

2 [1]

(ii) Use sketches and notes to show **one** method for improving the energy efficiency of the vehicle.

- 8 Using the table below, select the appropriate value of resistance, R , that gives a time of 1 second if the capacitance value is $100\ \mu\text{F}$.

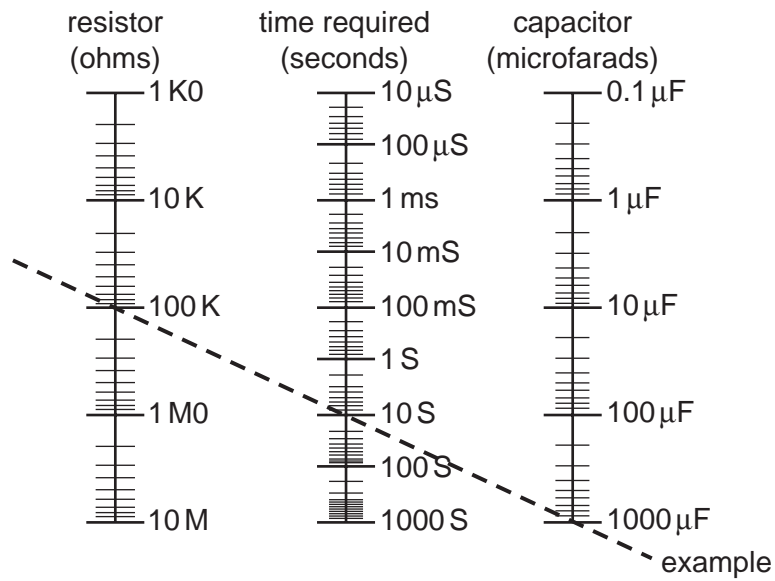

$R = \dots\dots\dots$ [1]

- 9 Give **one** example where a logic system is used in everyday life.

.....
..... [1]

- 10 Explain the need for a factor of safety when designing a structure.

.....
..... [2]

Section B

Answer **one** question from this section.

11 Fig. 1 shows a 555 timer circuit to control the time period for an LED.

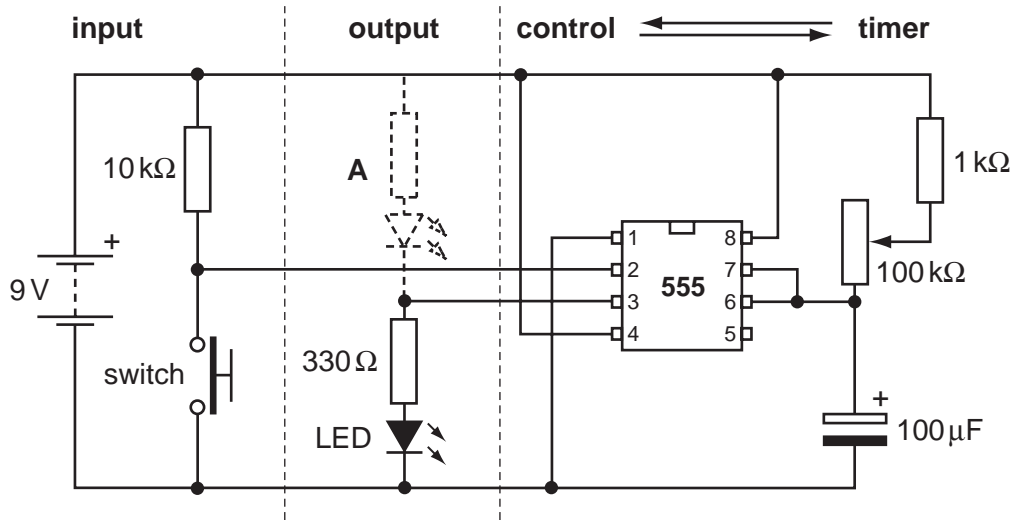

Fig. 1

(a) Explain, step by step, the operation of the circuit.

.....

.....

.....

..... [4]

(b) Explain the purpose of the 330Ω resistor.

.....

.....

..... [2]

(c) Explain the effect of moving the LED to position A as outlined by the dotted lines.

.....

.....

.....

..... [3]

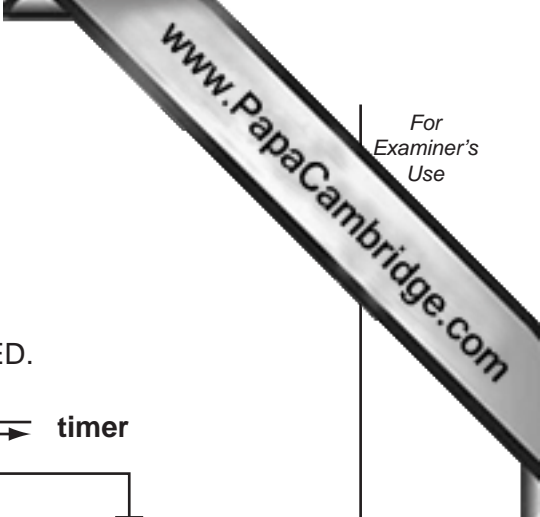

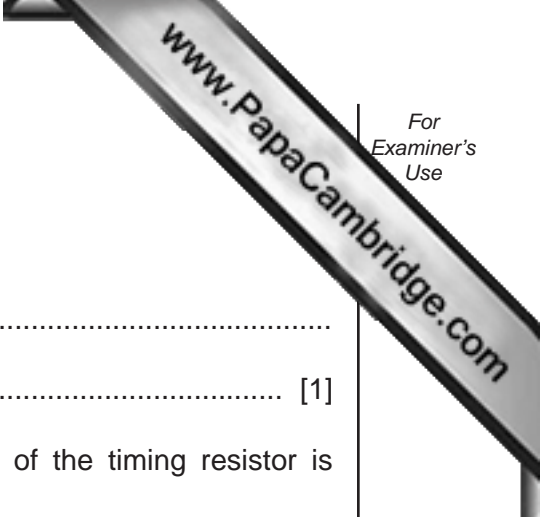

(d) The 100 μF capacitor is an electrolytic capacitor.

State why it should be connected according to its polarity.

.....
..... [1]

(e) The value of the timing capacitor is 100 μF and the value of the timing resistor is 100 $\text{k}\Omega$.

Calculate the time delay in seconds.

[4]

(f) Identify the type of switch used in the circuit shown in Fig. 1.

..... [1]

(g) The circuit is powered by a 9 V battery.

Explain the difference between a battery and a cell.

.....
..... [2]

(h) Logic gates can be used to control circuits and systems.

Fig. 2 shows a simple circuit using two switches to simulate inputs and a lamp to show the output.

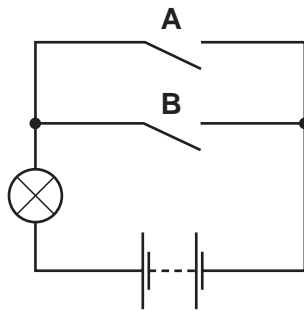

Fig. 2

(i) State the name of the logic gate that this circuit represents.

..... [1]

(ii) Sketch the symbol for this logic gate.

[3]

(iii) Identify the type of electrical arrangement of the switches in the circuit shown in Fig. 2.

..... [1]

(iv) Complete the truth table below for this logic circuit.

Input A	Input B	Output
0	0	
0	1	1
		1

[3]

12 Fig. 3 shows a design for a can-crushing press.

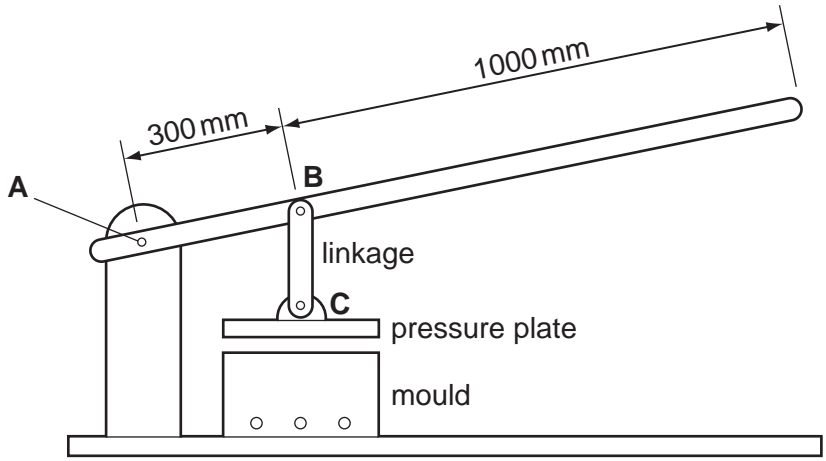

Fig. 3

(a) Using the example of the can-crushing press, explain what is meant by the term Mechanical Advantage.

.....

.....

..... [2]

(b) A force of 100 N is applied at the end of the handle.

Calculate the force that is transmitted to the pressure plate.

[3]

(c) (i) State the type of force acting on pin A.

..... [1]

(ii) Identify another component in the press that has this type of force acting on it.

..... [1]

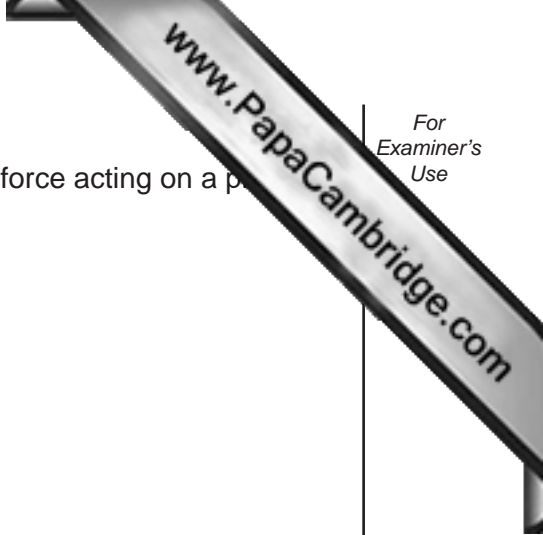

(iii) Use sketches and notes to show the result of this type of force acting on a p

[3]

(d) Suggest **one** way in which operation of the press could be made easier.

.....
..... [1]

(e) Identify the order of lever shown in Fig. 3.

..... [1]

(f) It is decided to add simple plain bearings at **A**, **B** and **C**.

(i) Explain the need for bearings in mechanical systems.

.....
.....
..... [2]

(ii) Use sketches and notes to show a simple plain bearing.

[3]

(g) Complete the table below.

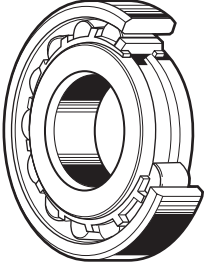
Bearing	Diagram	Example
[1]		Bicycle
Roller		[1]

(h) Lubrication is needed in mechanical systems.

(i) Give **two** reasons for lubricating mechanical systems.

.....
 [2]

(ii) State **two** types of lubricant and in each case give a specific example of use.

Type 1
 Use
 [2]

Type 2
 Use
 [2]

13 Stability in structures is very important.

(a) Look at Fig. 4 and for each structure add members to make them more stable.

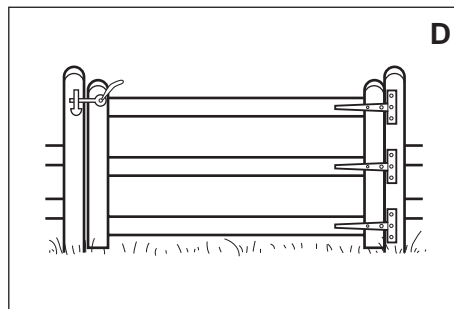
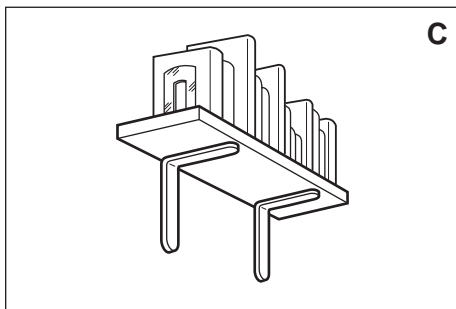
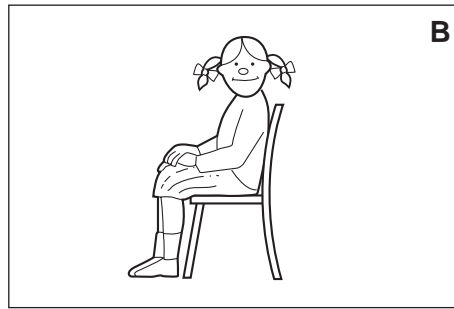
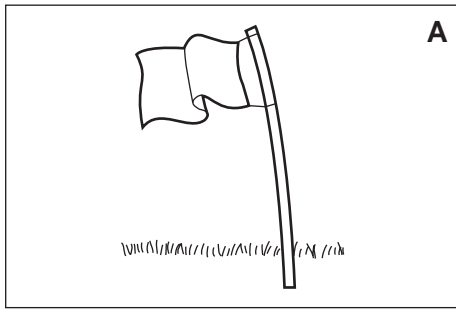

Fig. 4

[4]

(b) Each of the above structures is subject to static and dynamic loading.

Explain the difference between static and dynamic loading.

.....

.....

..... [2]

(c) A typical numerical value for the factor of safety for a bridge is 4.

Explain why this is so.

.....

.....

..... [3]

(d) Complete the table below to show different joining methods in structures.

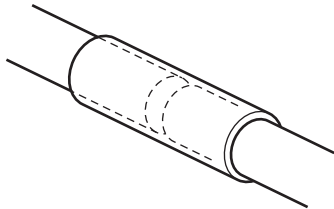
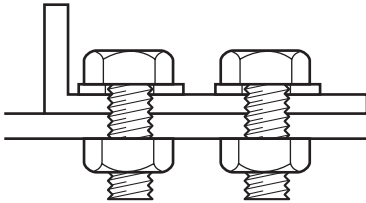
Joining method	Diagram	Use
Gusset plate	[2]	[1]
[1]		Joining tent poles
Nut and bolt		[1]

(e) Laminating is a structural construction method.

(i) Use sketches and notes to show the laminated structure of plywood.

[2]

(ii) Explain the way in which laminating improves the structural capabilities of plywood.

.....

 [2]

- (f) The selection of materials is important when designing structures.

Fig. 5 shows a lintel made from concrete.

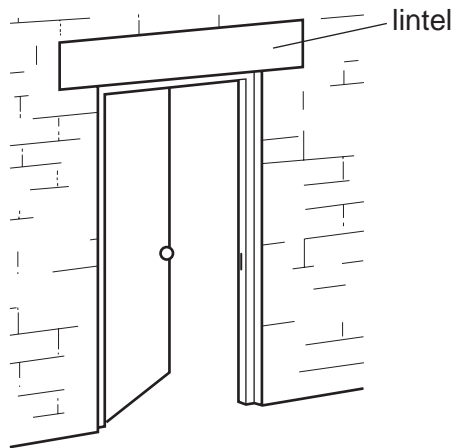

Fig. 5

- (i) Use sketches and notes to show the forces acting within the lintel.

[2]

- (ii) Explain, using sketches and notes, how the concrete lintel would be reinforced to make it suitable for this use.

[2]

- (iii) Show, using sketches and notes, how a strain gauge is used to measure the deflection of the lintel.

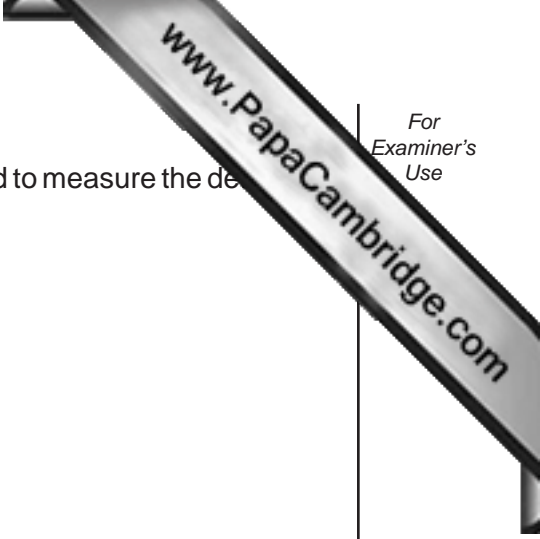

[3]

