



UNIVERSITY OF CAMBRIDGE INTERNATIONAL EXAMINATIONS
International General Certificate of Secondary Education

CANDIDATE
NAME

CENTRE
NUMBER

| | | | | |
|--|--|--|--|--|
| | | | | |
|--|--|--|--|--|

CANDIDATE
NUMBER

| | | | | |
|--|--|--|--|--|
| | | | | |
|--|--|--|--|--|

* 2 8 5 0 8 0 0 6 3 *

DESIGN AND TECHNOLOGY

0445/31

Paper 3 Resistant Materials

October/November 2013

1 hour

Candidates answer on the Question Paper.

No Additional Materials are required.

To be taken together with Paper 1 in one session of 2 hours 15 minutes.

READ THESE INSTRUCTIONS FIRST

Write your Centre number, candidate number and name on all the work you hand in.

Write in blue or black pen.

You may use a soft pencil for any diagrams, graphs or rough working.

Do not use staples, paper clips, highlighters, glue or correction fluid.

DO **NOT** WRITE IN ANY BARCODES.

Section A

Answer **all** questions in this section.

Section B

Answer **one** question in this section.

You may use a calculator.

The total of the marks for this paper is 50.

The number of marks is given in brackets [] at the end of each question or part question.

| For Examiner's Use | |
|--------------------|--|
| Section A | |
| Section B | |
| Total | |

This document consists of **14** printed pages and **2** blank pages.



Section A

Answer **all** questions in this section.

- 1 Fig. 1 shows part of a toy made from 4 mm thick manufactured board.

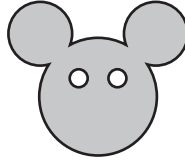

Fig. 1



- (a) Give **one** benefit of using a template to mark out the shape.

..... [1]

- (b) Name a tool that could be used to cut out the shape.

..... [1]

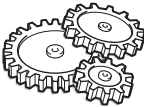
- 2 Complete the table below by naming a specific material and giving a reason for your choice.

| Product | Specific material | Reason for choice |
|---|-------------------|-------------------|
|  plastic gears | | |
|  wooden rolling pin | | |

[4]

- 3 Fig. 2 shows three different types of rivet.

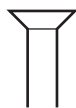

A



B



C

Fig. 2

Name each type of rivet.

rivet **A**

rivet **B**

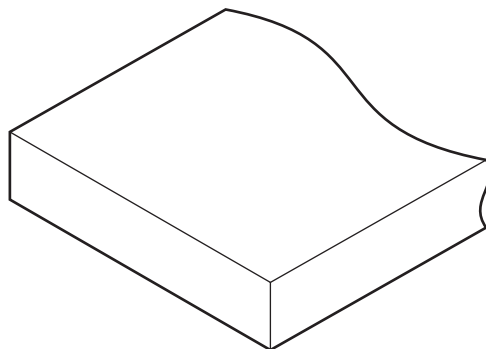

rivet **C** [3]

4 Complete the sketch below to show blockboard.

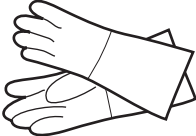

[2]

5 Complete the table below by describing a situation in the workshop where each of the following items of safety equipment must be worn.

| Safety equipment | Situation where it must be worn |
|---|---------------------------------|
|  ear defenders | |
|  gauntlets | |
|  apron | |

[3]

6 Fig. 3 shows a corner bridle joint.

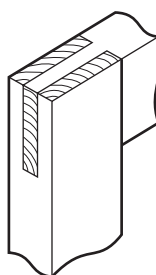

Fig. 3

Name **three** marking out tools that could be used to mark out the corner bridle joint.

1

2

3 [3]

7 Fig. 4 shows a plastic food tray and fork.

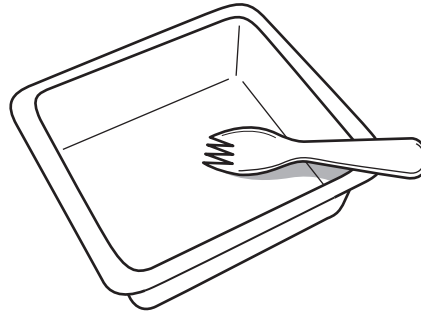

Fig. 4

Name the process that would be used to make:

(a) the food tray;

..... [1]

(b) the fork.

..... [1]

8 Fig. 5 shows a picnic table made from hardwood.

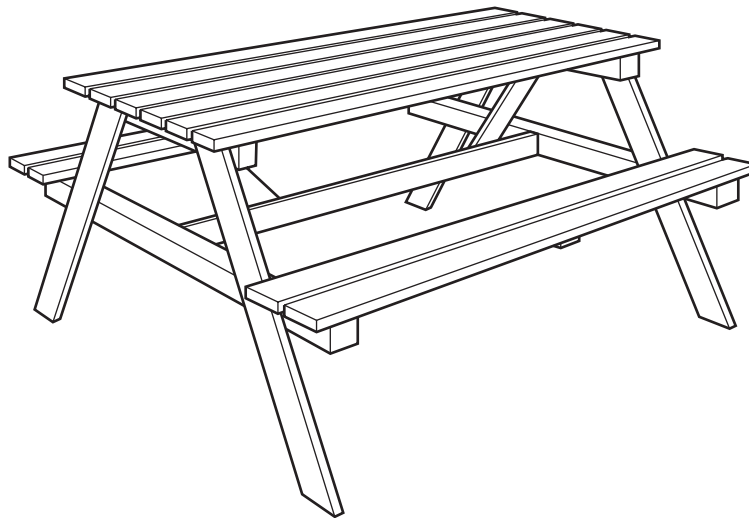

Fig. 5

Name **two** different methods of joining that could be used in the manufacture of the picnic table.

1

2 [2]

- 9 Explain the purpose of the safe edge on a hand file when filing the corner of the shape shown in Fig. 6.

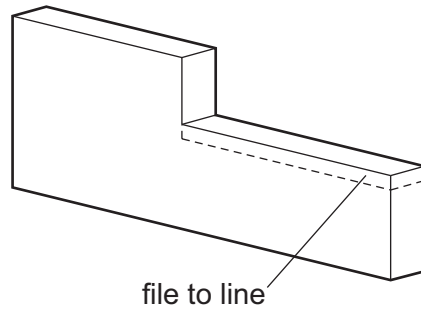

Fig. 6

.....

.....

..... [2]

- 10 Fig. 7 shows a dish made from copper being shaped. Explain why it would be necessary to anneal the copper during shaping.

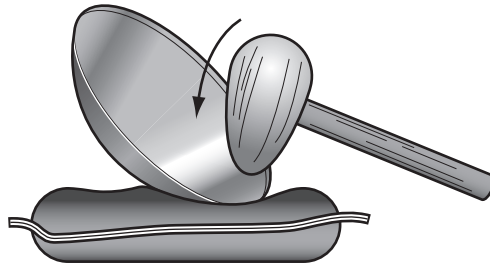

Fig. 7

.....

.....

..... [2]

Section B

Answer **one** question in this section.

- 11 Fig. 8 shows an incomplete design for a wooden toolbox made from 15 mm thick softwood.

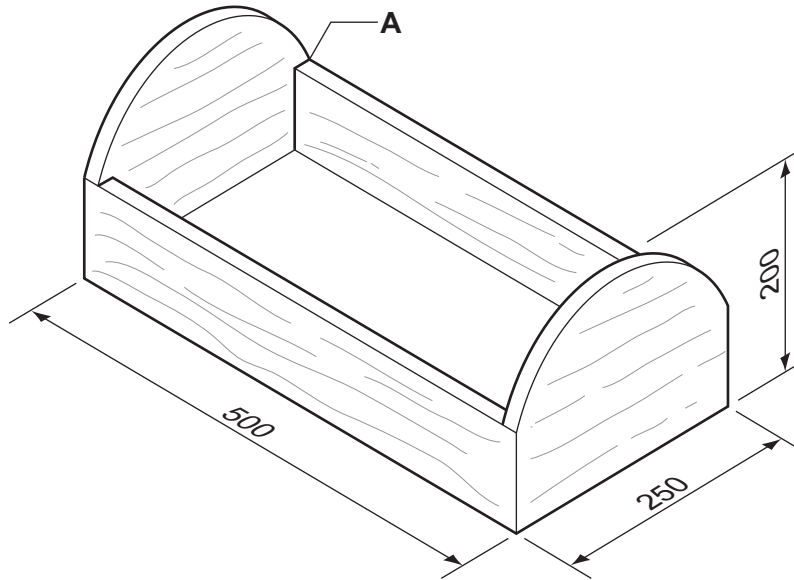

Fig. 8

- (a) Give **two** items of research a designer would need to find out when designing a toolbox.

1

2 [2]

- (b) (i) Give a reason for using softwood for the toolbox.

..... [1]

- (ii) Name a suitable softwood for the toolbox.

..... [1]

- (c) Sketch and name a corner joint suitable for corner **A**.

(d) Fig. 9 shows one end of the toolbox marked out ready to be cut to shape.

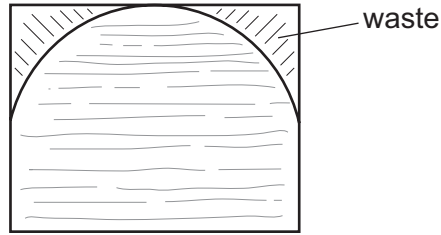

15 mm thick softwood

Fig. 9

(i) Name a suitable portable power tool that could be used to cut out the shape.

..... [1]

(ii) State **one** safety precaution you must take when using portable power tools.

..... [1]

(e) In the space below, use sketches and notes to show modifications to the toolbox so that it could be carried comfortably. Include details of the materials and any constructions used.

[3]

- (f) The base of the toolbox is made from 9 mm thick manufactured board.
Use sketches and notes to show **two** methods of fitting the base to the toolbox.

Method 1

[3]

Method 2

[3]

- (g) When many tools are stored in the toolbox they are difficult to find.
Use sketches and notes to show how the space inside the toolbox could be divided into three different size areas so that the tools can be stored safely.
Include details of the materials and any constructions used.

[6]

- 12 Fig. 10 shows views of a display unit made from two separate pieces of acrylic. The two pieces clip together using lugs.

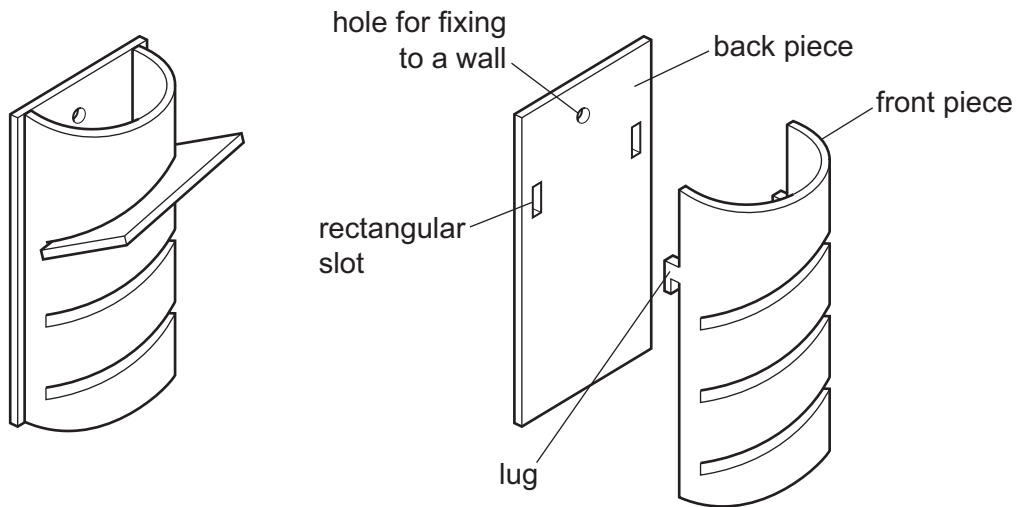

Fig. 10

- (a) (i) State whether acrylic is a thermoplastic or a thermosetting plastic.

..... [1]

- (ii) Explain the difference between a thermoplastic and a thermosetting plastic.

.....

 [2]

- (b) Sketch the development (net) of the front piece of the display unit. Do not include details of the slots in the front piece.

[4]

(c) Use sketches and notes to show how the curved shape of the front piece could be produced.

[3]

(d) Describe how **one** of the rectangular slots in the back piece could be produced.

.....
.....
.....
.....
..... [3]

(e) Use sketches and notes to show how the hole in the back piece could be:

(i) marked out;

[2]

(ii) drilled safely.

[2]

(f) The front piece could be fixed permanently to the back piece using acrylic cement. State **three** safety precautions you must take when using acrylic cement.

1

2

3 [3]

(g) Describe how the following items of equipment could be used when finishing the edges of the acrylic to a high quality:

(i) wet and dry (silicon carbide) paper;

..... [1]

(ii) polishing mop and polishing compound.

..... [1]

(h) When assembled, the lugs prevent the display unit from fitting flat against the wall. Use sketches and notes to show how this problem could be overcome.

[3]

13 Fig. 11 shows details of a kitchen roll holder.

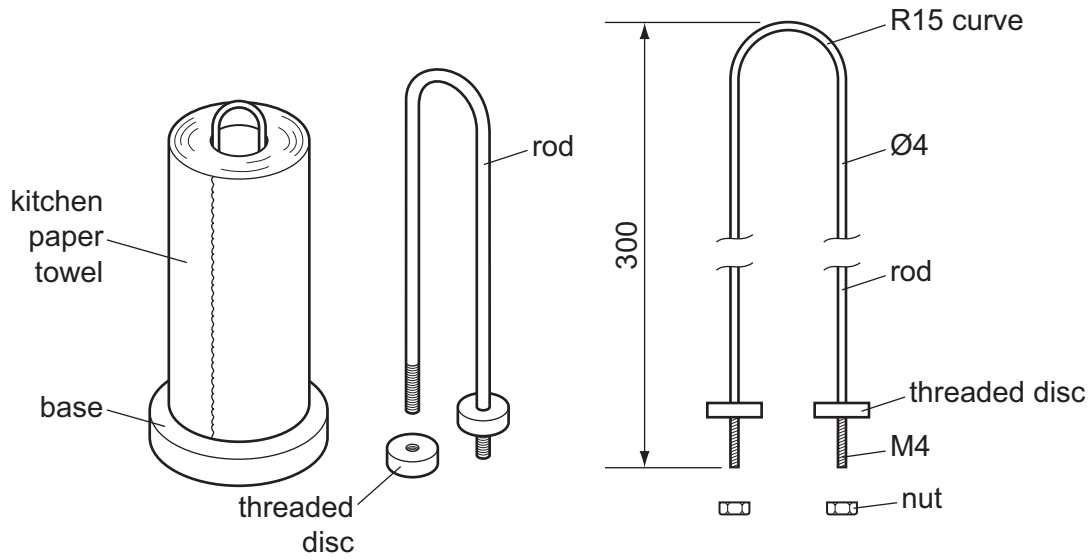

Fig. 11

(a) (i) Name a suitable ferrous metal for the rod.

..... [1]

(ii) Name a suitable non-ferrous metal for the rod.

..... [1]

(iii) Give **two** benefits of using a non-ferrous metal for the rod.

1

2 [2]

(b) Use sketches and notes to show how the M4 thread could be produced on **one** end of the rod before it is bent to shape.

[4]

- (c) Use sketches and notes to show a bending jig that could be used when bending the R15 curve shown in Fig. 11.

[4]

- (d) Complete the drawing in Fig. 12 to show how the rod could be attached to the base using M4 nuts.

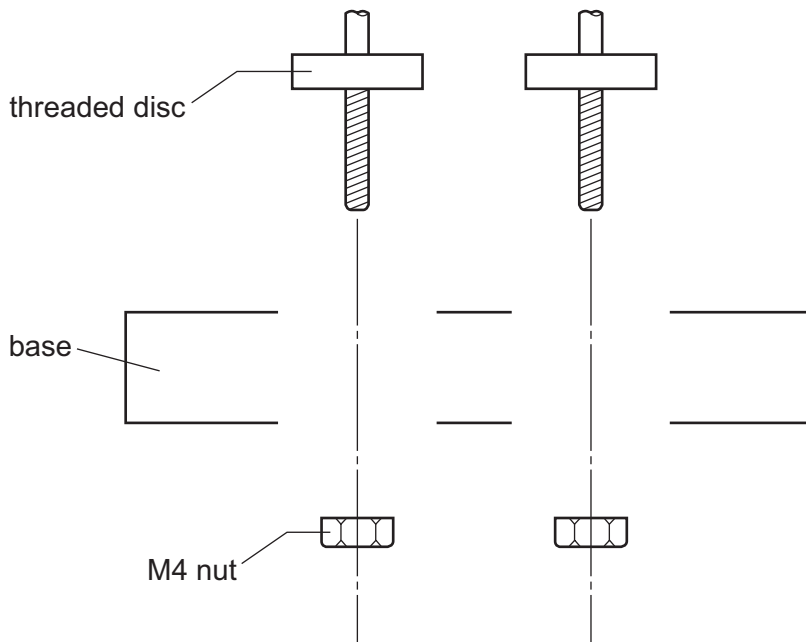

Fig. 12

[3]

(e) Fig. 13 shows the base marked out on a block of hardwood.

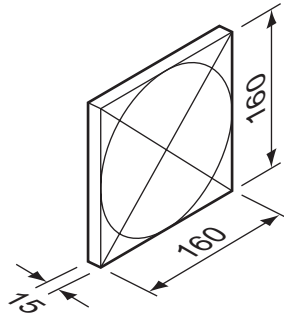

Fig. 13

Use sketches and notes to show how the base could be produced in a school workshop.

[6]

(f) (i) Name a suitable finish for the hardwood base.

..... [1]

(ii) List **three** stages in preparing and applying your chosen finish.

1

2

3 [3]

BLANK PAGE

Permission to reproduce items where third-party owned material protected by copyright is included has been sought and cleared where possible. Every reasonable effort has been made by the publisher (UCLES) to trace copyright holders, but if any items requiring clearance have unwittingly been included the publisher will be pleased to make amends at the earliest possible opportunity.

University of Cambridge International Examinations is part of the Cambridge Assessment Group. Cambridge Assessment is the brand name of University of Cambridge Local Examinations Syndicate (UCLES), which is itself a department of the University of Cambridge.