

CANDIDATE
NAME

CENTRE
NUMBER

--	--	--	--	--

CANDIDATE
NUMBER

--	--	--	--

DESIGN AND TECHNOLOGY

0445/04

Paper 4 Systems and Control

For Examination from 2015

SPECIMEN PAPER

1 hour

Candidates answer on the Question Paper.

No Additional Materials are required.

READ THESE INSTRUCTIONS FIRST

Write your Centre number, candidate number and name in the spaces at the top of this page.

Write in dark blue or black pen.

You may use an HB pencil for any diagrams, graphs or rough working.

Do not use staples, paper clips, glue or correction fluid.

You may use a calculator.

Section A

Answer **all** questions.

Section B

Answer **one** question.

The total of the marks for this paper is 50.

At the end of the examination, fasten all your work securely together.

The number of marks is given in brackets [] at the end of each question or part question.

This document consists of **15** printed pages and **1** blank page.

Section A

Answer **all** questions in this section.

1 Fig. 1 shows a beam under load.

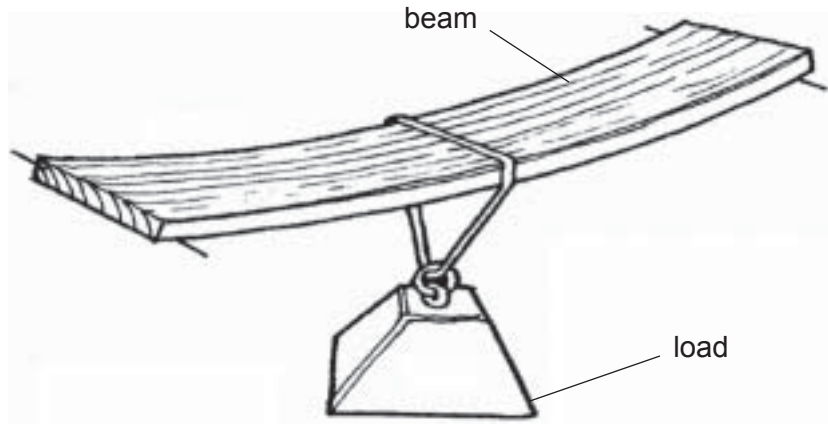

Fig. 1

Add labels to Fig. 1 to show clearly:

- tension forces in the beam
- compression forces in the beam.

[2]

2 Complete the diagram below to show the energy conversions that take place when a torch is switched on.

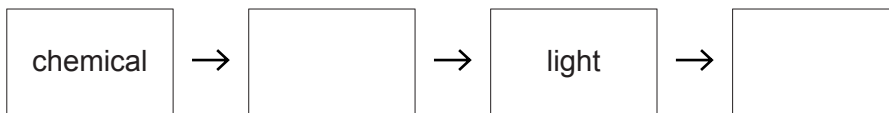

[2]

3 State **one** advantage of chain and sprocket transmission over belt and pulley transmission.

.....[1]

4 Give **one** example of a natural structure.

.....[1]

5 Fig. 2 shows two different gear systems.



Fig. 2

(a) Name each gear system.

A

B [2]

(b) Explain the effect of both systems on the direction of motion transmitted.

..... [1]

6 Fig. 3 shows the circuit using an LED.

The LED has a forward voltage of 2V and a current of 0.01A flowing through it.

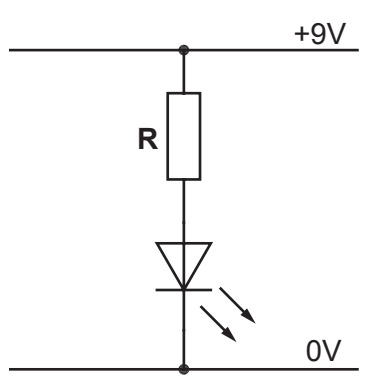

Fig. 3

Calculate the value of R

Use the formula $V = I \times R$



7 Use sketches and notes to show how a gusset plate can be used to reinforce a joint in

[2]

8 Name **two** types of motion **other than** rotary and reciprocating.

1

2 [2]

9 Give **one** reason why plastics are used for making casings for electronic circuits.

.....
..... [1]

10 The diagrams below show two different orders of lever.
Give the order and a use for each lever.



Order:

Use: [2]

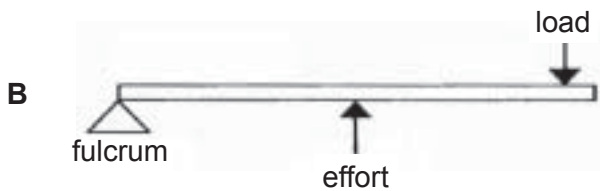

Order:

Use: [2]

11 Fig. 4 shows a building.

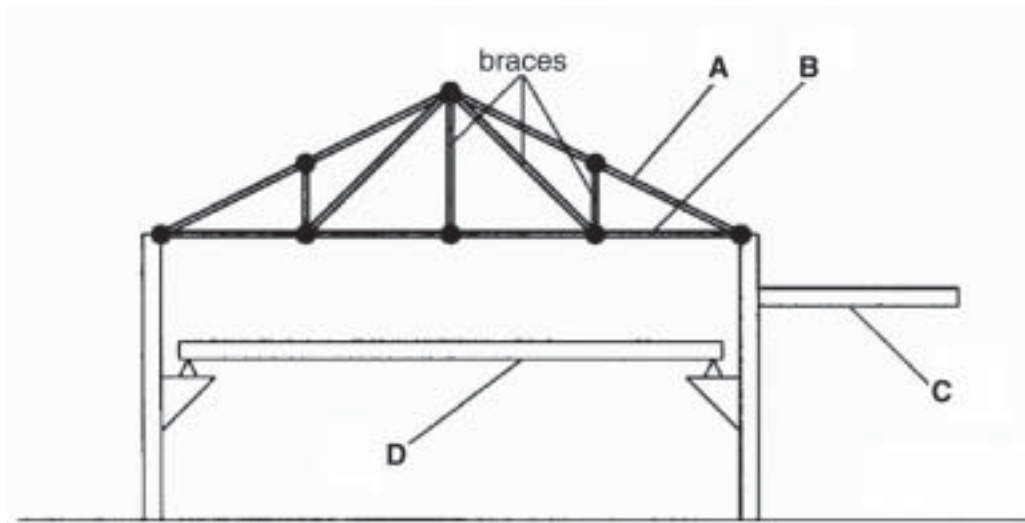

Fig. 4

Match the letters from the diagram to the building components listed below.

Letter from diagram	Building component
	Cantilever beam
	Tie (Member in tension)
	Strut (Member in compression)
	Simply supported beam

[4]

Section B

Answer **one** question in this section.

12 Fig. 5 shows a 555 timer circuit used in the construction of a kitchen timer.

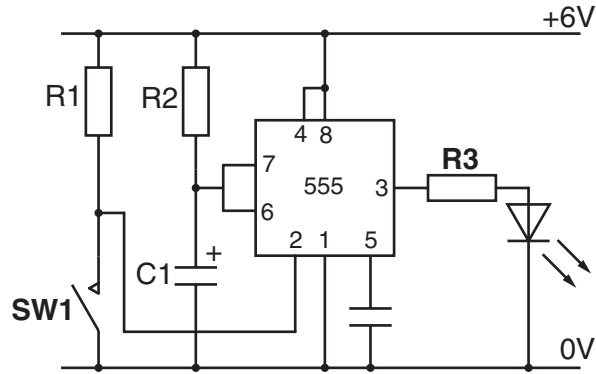

Fig. 5

(a) Describe what happens when **SW1** is pressed and released.

.....

.....

.....

.....

.....

..... [3]

(b) Explain how the value of the time delay is controlled.

.....

.....

..... [2]

(c) Explain the purpose of **R3**.

.....

.....

..... [2]



(d) Name the type of switch used in this circuit and explain why it is the most suitable of switch to use.

Name:

Reason for selection:

.....

 [3]

(e) Fig. 6 shows a modification to the circuit.

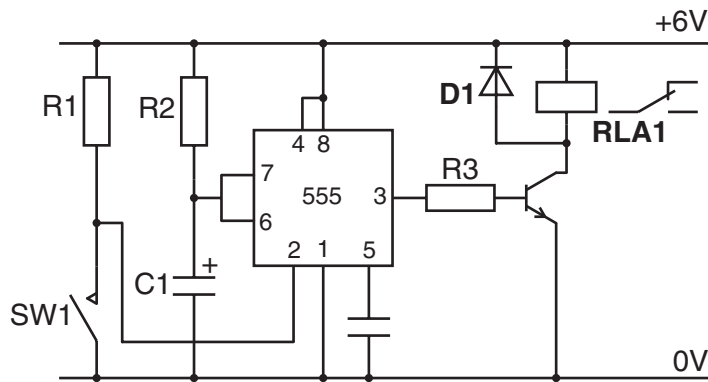

Fig. 6

(i) Name and explain the purpose of **RLA1**.

Name:

Purpose:

.....
 [4]

(ii) Name and explain the purpose of **D1**.

Name:

Purpose:

.....
 [3]

- (f) Another method of controlling systems is to use logic circuits. Fig. 7 shows logic gate symbols and their truth tables.

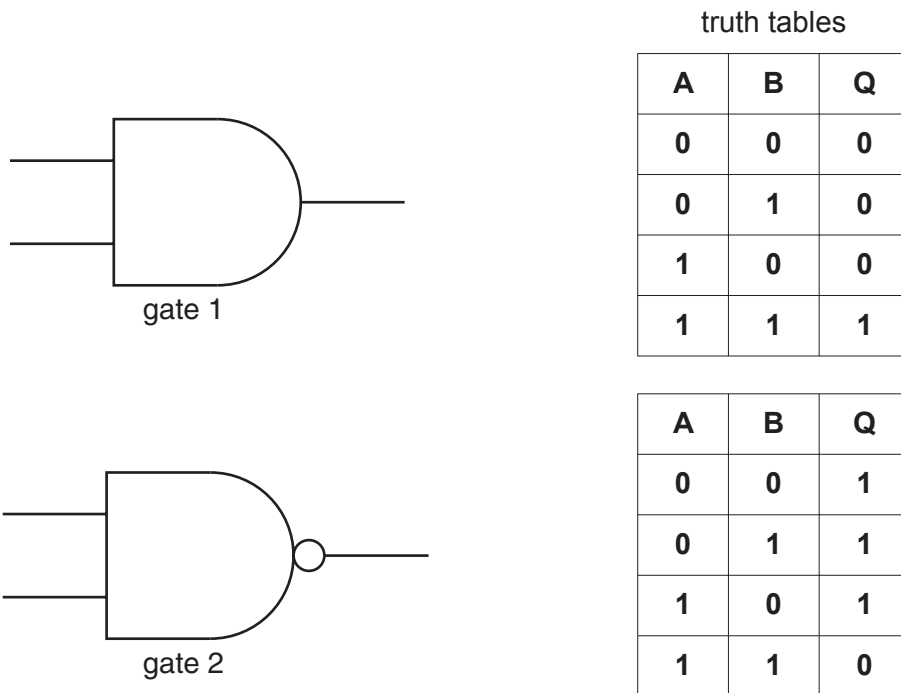

Fig. 7

- (i) Name each logic gate.

Gate 1

Gate 2 [2]

- (ii) Complete the diagram below to show how a number of logic gates of 'gate 1' type could be used to control a four digit code lock.

correct signals are logic 1

digit 1 signal

digit 2 signal

digit 3 signal

digit 4 signal

signal to release lock

(iii) Fig. 8 shows a 7 segment display that could be used to display a code number.

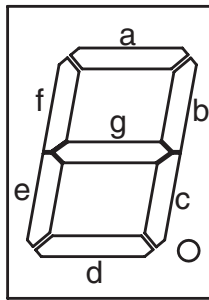

Fig. 8

State the segments that must be lit to display a number two.

.....[1]

(iv) Describe **one** way of modelling the seven segment display circuit before building it.

.....

.....[2]

13 Fig. 9 shows a roof structure.

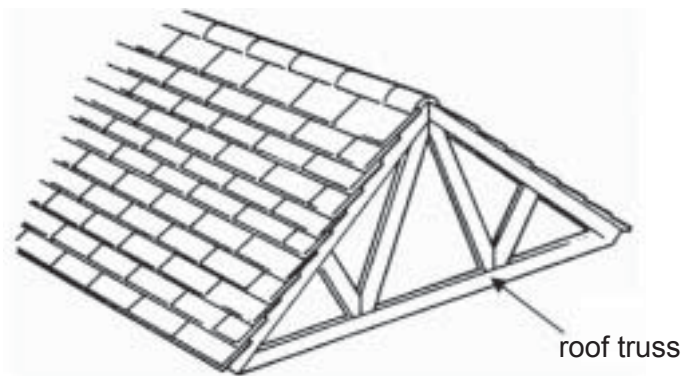

Fig. 9

(a) The roof experiences static loading and dynamic loading.

(i) Explain the term static loading and give an example for this type of loading.

static loading:

example:.....[3]

(ii) Explain the term dynamic loading and give an example for this type of loading.

dynamic loading:

example:.....[3]

(b) Explain why the roof truss is constructed in this way.

.....

.....

..... [2]

(c) Fig. 10 shows the loading on the truss.

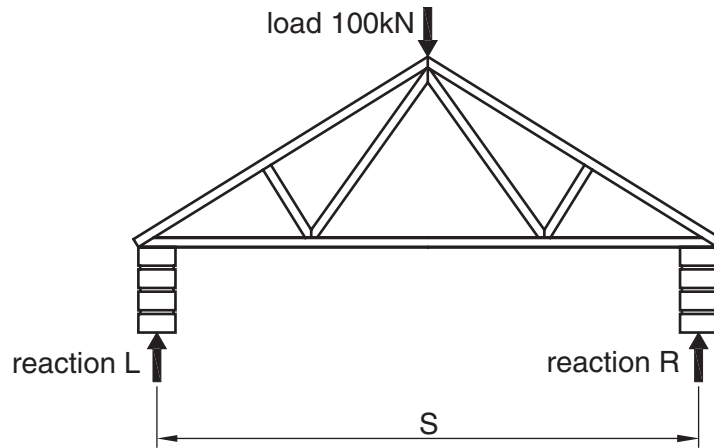

Fig. 10

Determine the values of the reactions L and R .

[3]

(d) It is decided to use a strain gauge to measure the deflection in the roof truss. Use sketches and notes to show how a strain gauge works.

[4]

(e) Fig. 11 shows a doorway and lintel.

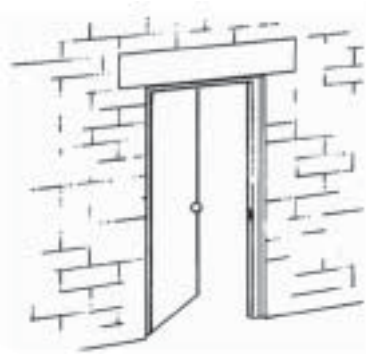

Fig. 11

An **I** section steel beam is used as the lintel.
Use sketches and notes to explain why this type of beam is used.

[3]

(f) Fig. 12 shows a stress/strain graph for mild steel.

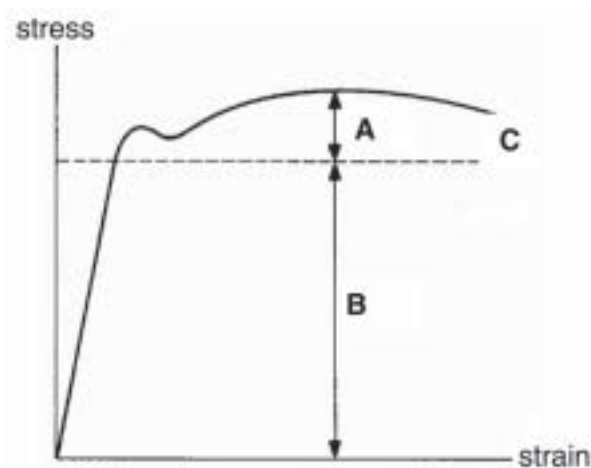

Fig. 12

(i) Name the features **A**, **B** and **C**.

A

B

C [3]

(ii) A test piece 300 mm long experiences strain of 5×10^{-3} .

Calculate the new length of the test piece.

Use the formula $\text{strain} = \frac{\text{change in length}}{\text{original length}}$

[4]

14 Fig. 13 shows a pulley and belt drive system.

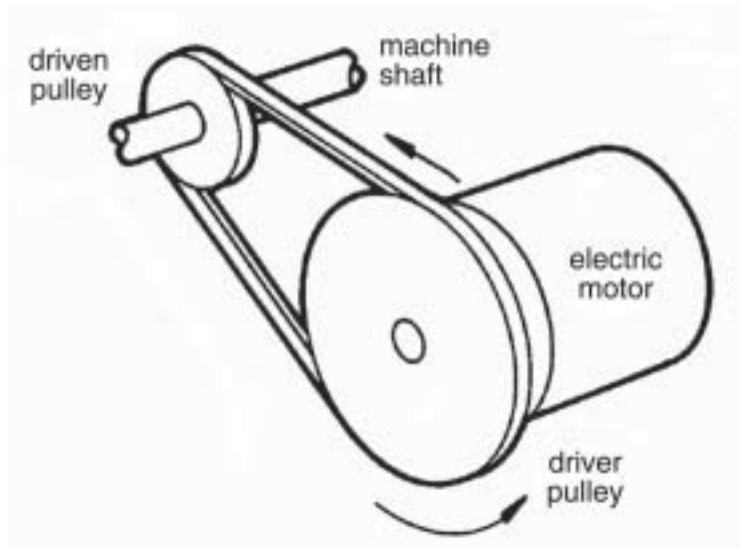

Fig. 13

(a) Explain the effect of this arrangement on the speed of the driven pulley.

.....
.....
..... [2]

(b) Explain the effect of this arrangement on the direction of rotation of the driven pulley.

.....
.....

- (c) The diameter of the driven pulley is 20 mm and the diameter of the driver pulley is 40 mm. The speed of the driver pulley is 150 rpm. Calculate the speed of the driven pulley.

[3]

- (d) Fig. 14 shows a stepped cone pulley system.

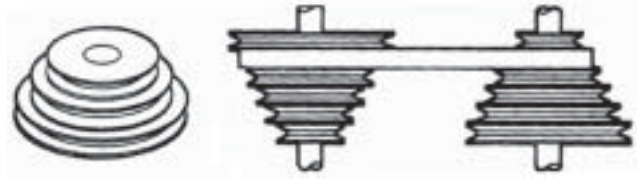

Fig. 14

- (i) Give an example of a use for this type of system.
..... [1]

- (ii) Explain why the pulleys and belts are V shaped.
.....
.....
..... [2]

- (iii) Explain why the pulleys are arranged in this way.
.....
.....
.....
..... [3]

(e) Fig. 15 shows a winch mechanism.

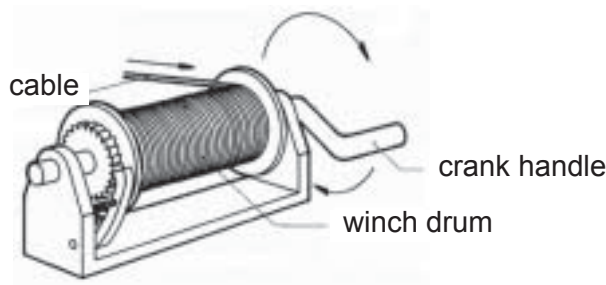

Fig. 15

The winch uses a ratchet and pawl to prevent the drum from unwinding.

(i) Add labels to Fig. 15 to show the:

- ratchet,
- pawl.

[2]

(ii) Give one other example of the use of a ratchet and pawl.

.....[1]

(f) Fig. 16 shows a pear shaped cam and follower.

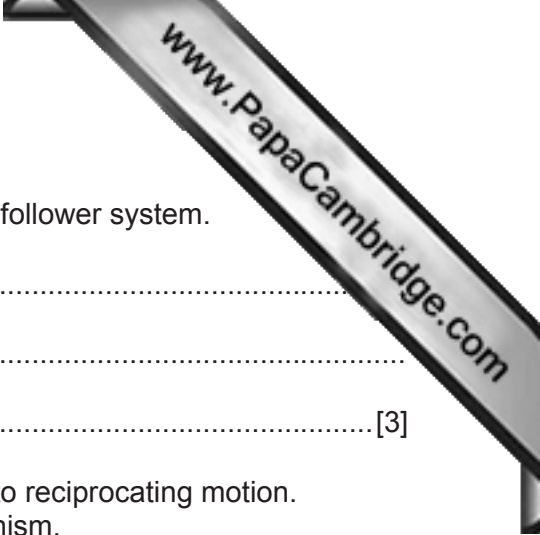

Fig. 16

(i) Add labels to Fig. 16 to show how the system converts rotary motion to reciprocating motion. [2]

(ii) Give **one** application for this type of system.

.....[1]



(iii) During the rotation of the cam there is a dwell period.
Explain what is meant by the dwell period for a cam and follower system.

.....
.....
..... [3]

(iv) A crank and slider can be used to convert rotary motion to reciprocating motion.
Sketch and label a diagram of a crank and slider mechanism.

[3]

