



# Cambridge IGCSE™ (9–1)

CANDIDATE NAME



CENTRE NUMBER

--	--	--	--	--

CANDIDATE NUMBER

--	--	--	--



## DESIGN & TECHNOLOGY

0979/32

Paper 3 Resistant Materials

October/November 2024

1 hour

You must answer on the question paper.

No additional materials are needed.

### INSTRUCTIONS

- Section A: answer **all** questions.
- Section B: answer **one** question.
- Use a black or dark blue pen. You may use an HB pencil for any diagrams or graphs.
- Write your name, centre number and candidate number in the boxes at the top of the page.
- Answer in the space provided.
- Do **not** use an erasable pen or correction fluid.
- Do **not** write on any bar codes.
- You may use a calculator.

### INFORMATION

- The total mark for this paper is 50.
- The number of marks for each question or part question is shown in brackets [ ].
- All dimensions are in millimetres unless otherwise stated.

This document has **24** pages. Any blank pages are indicated.





### Section A

Answer **all** questions in this section.

- 1 Carbon fibre reinforced plastic (CFRP) is used to build many different aircraft parts. State **two** benefits of using carbon fibre reinforced plastic (CFRP) to build aircraft parts.

1 .....

2 .....

[2]

- 2 Fig. 2.1 shows pipes used for plumbing being joined together.

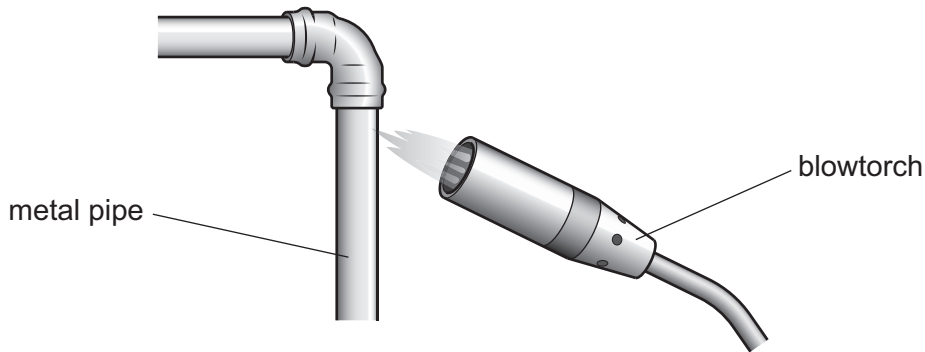

Fig. 2.1

- (a) Name the metal used for the pipes.

..... [1]

- (b) Name the method used to join the metal pipes together.

..... [1]

- 3 Fig. 3.1 shows a through mortise and tenon joint.

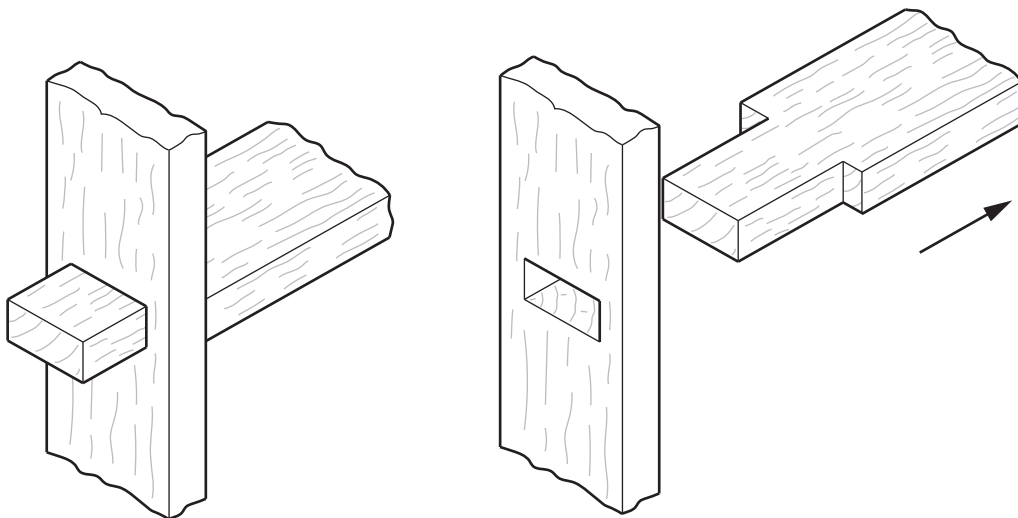

Fig. 3.1

Add sketches and notes to Fig. 3.1 to show how the joint could be prevented from being pulled apart in the direction of the arrow shown. [3]





4 Fig. 4.1 shows three products made of different materials.



mild steel wheelbarrow body



silver pendant



brass tap

**Fig. 4.1**

State a suitable different finish for each product:

mild steel wheelbarrow body .....

silver pendant .....

brass tap .....

[3]

5 Fig. 5.1 shows 4 mm thick acrylic sheet that has been shaped.

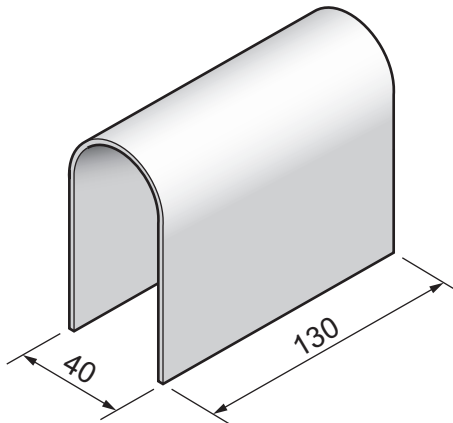

**Fig. 5.1**

Use sketches and notes to show how the curved shape could be produced.

[3]

[Turn over]



DO NOT WRITE IN THIS MARGIN



6 Fig. 6.1 shows details of a steam chest that would be used to steam bend wood.

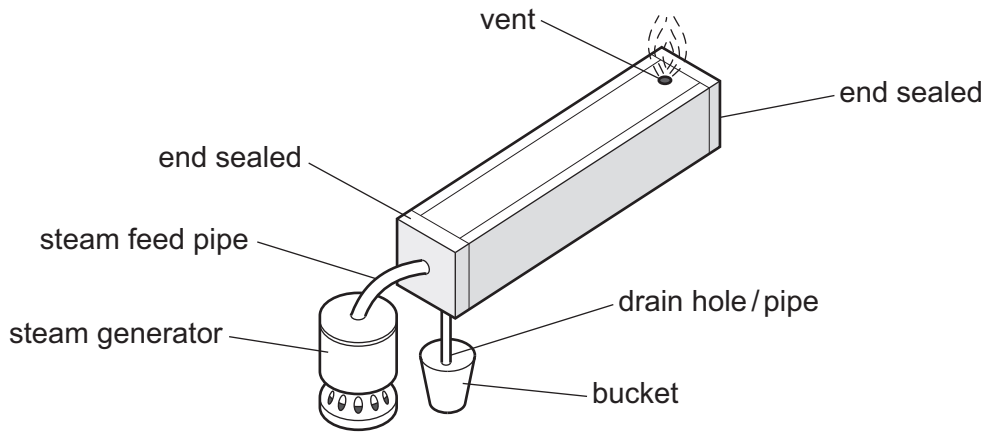

Fig. 6.1

List **three** stages to describe how the steam chest would be used to steam bend wood.

- 1 .....
- 2 .....
- 3 .....

[3]

7 Fig. 7.1 shows part of a length of mild steel square tube and an engineer's vice. A hacksaw will be used to cut the tube to make a 90° bend.

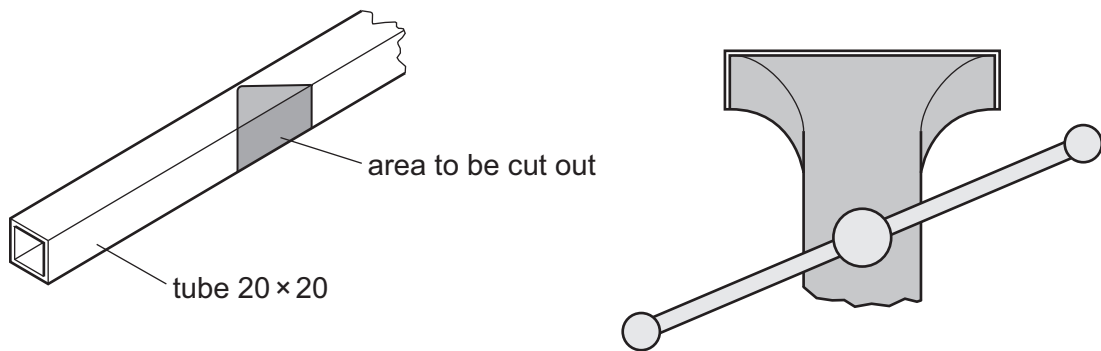

Fig. 7.1

Draw on Fig. 7.1 to show how the mild steel tube would be held in the engineer's vice while the saw cuts are made.

[2]





8 Fig. 8.1 shows a body shell for a car made from glass reinforced plastic (GRP).

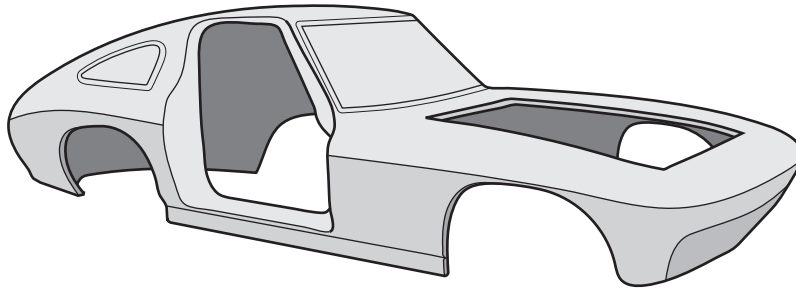

Fig. 8.1

Explain what is meant by the term 'glass reinforced plastic' (GRP).

.....  
.....  
..... [2]

9 Fig. 9.1 shows a variety of supermarket shopping bags made from plastic and the symbol showing the type of plastic from which the bags are made.

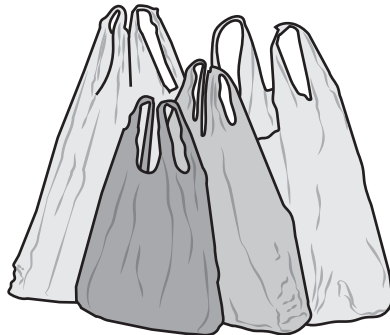

Fig. 9.1

(a) Name the type of plastic from which the bags are made.

..... [1]

(b) Many supermarket shopping bags are thrown away.  
State **two** ways supermarkets could reduce the environmental waste produced by the use of plastic shopping bags.

1 .....

2 .....

[2]



DO NOT WRITE IN THIS MARGIN



10 Fig. 10.1 shows two hardwood stools, **A** and **B**.  
Stool **A** has been fabricated and stool **B** has been made by steam bending.

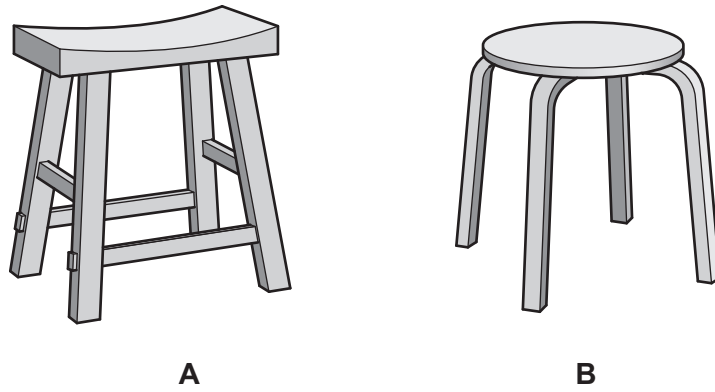

Fig. 10.1

Explain why stool **B** would be cheaper to mass produce than stool **A**.

.....  
.....  
..... [2]

DO NOT WRITE IN THIS MARGIN





Section B

Answer **one** question from this section.

11 Fig. 11.1 shows an incomplete design for a tablet stand made of hardwood.

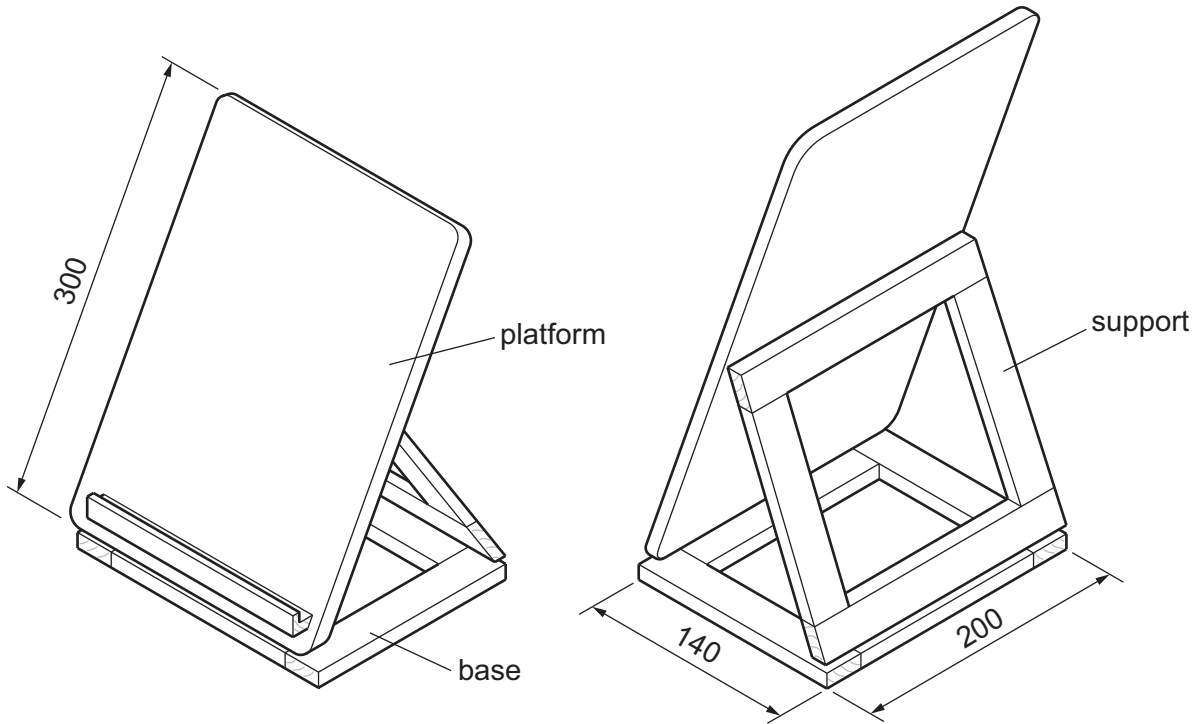

base and support frames 25 mm wide × 10 mm thick  
platform 10 mm thick

Fig. 11.1

(a) Give **two** benefits of using hardwood for the tablet stand.

1 .....

2 .....

[2]

(b) The four sides of the base will be marked out and cut from a 700 mm length of hardwood.

(i) Name **two** tools that could be used to mark out the sides of the base.

1 .....

2 .....

[2]

(ii) Name a specific type of saw that could be used with a bench hook to saw the sides to the required lengths.

..... [1]



DO NOT WRITE IN THIS MARGIN



(c) Fig. 11.2 shows a dowel joint used at the corners of the base and support.

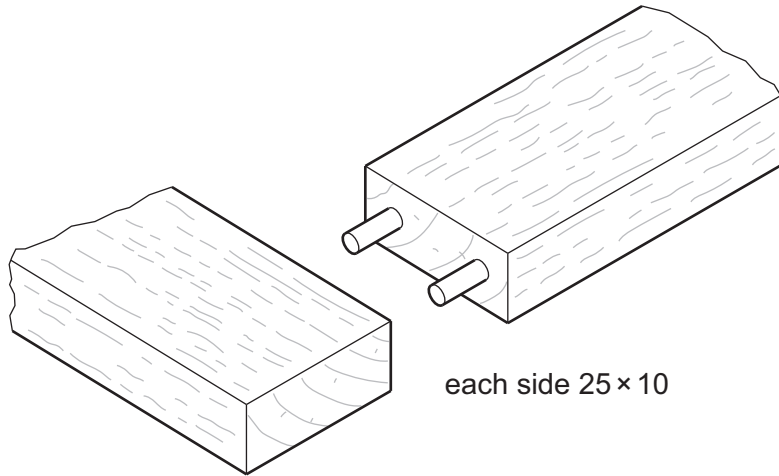

Fig. 11.2

Use sketches and notes to show a design for a jig that could be used when marking out the positions for the holes to be drilled for the dowels.

[4]

(d) Fig. 11.3 shows the base of the tablet stand glued and clamped together.

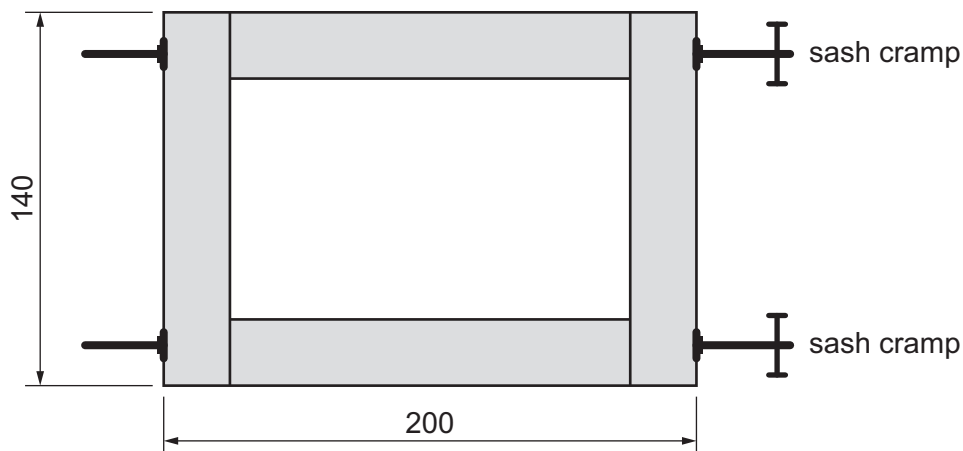

Fig. 11.3

Add sketches and notes to Fig. 11.3 to show **two** methods of checking that the sides are clamped squarely to each other. [4]







(e) The platform and the support will be joined to the base by means of butt hinges.

(i) Complete Fig. 11.4 to show a butt hinge.

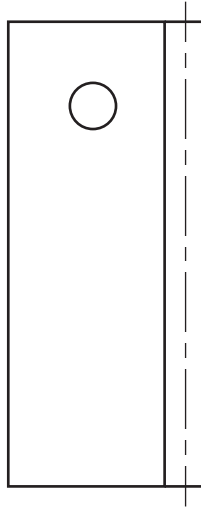

Fig. 11.4

[3]

(ii) Name a different type of hinge that could be used to join the platform and the support to the base.

..... [1]

(f) Use sketches and notes to show modifications to the tablet stand so that the platform could be tilted and locked securely at **three** different angles. Give details of all materials and constructions used.

[4]



DO NOT WRITE IN THIS MARGIN



(g) Describe **one** way in which the designer has considered each of the following when designing the tablet stand.

(i) ergonomics

.....  
..... [2]

(ii) sustainability of materials used

.....  
..... [2]

DO NOT WRITE IN THIS MARGIN

DO NOT WRITE IN THIS MARGIN

DO NOT WRITE IN THIS MARGIN

DO NOT WRITE IN THIS MARGIN

DO NOT WRITE IN THIS MARGIN





12 Fig. 12.1 shows an incomplete design for a coat hook used by children. The coat hook is made from 2 mm thick mild steel sheet.

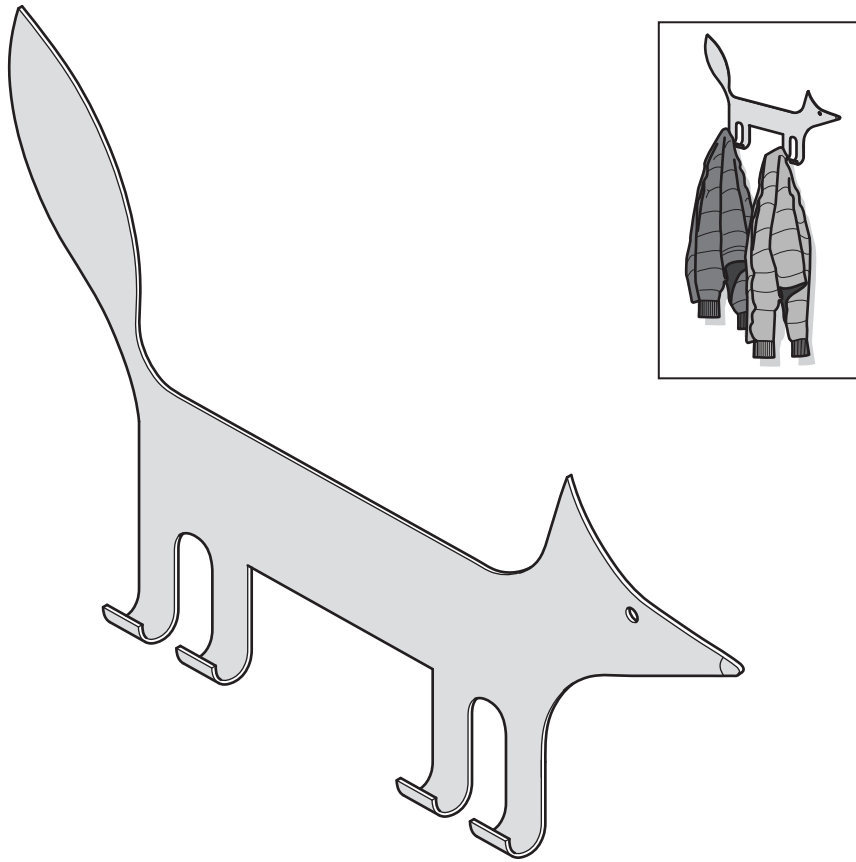

Fig. 12.1

(a) Fig. 12.2 shows a card template of the coat hook shape glued onto mild steel sheet. The waste between the legs, labelled **A**, will be removed by drilling a hole and then using a saw to cut out the remaining sheet metal.

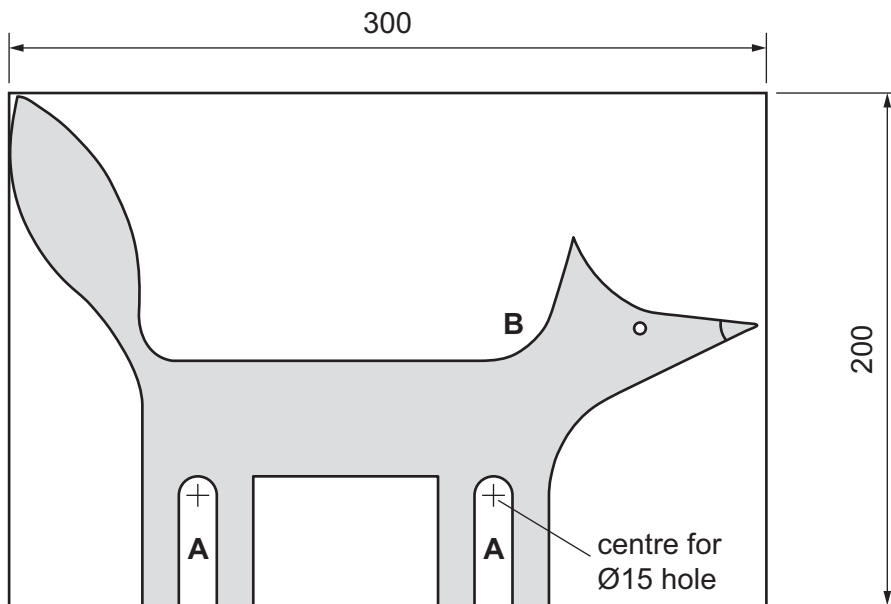

Fig. 12.2



DO NOT WRITE IN THIS MARGIN



(i) State **one** reason why a centre punch would be used to mark the centre where the holes will be drilled.

..... [1]

(ii) State **one** reason why a Ø6 pilot hole would be drilled before using a Ø15 drill.

..... [1]

(iii) Name a suitable saw that could be used to remove the remaining waste after the Ø15 hole has been drilled.

..... [1]

(iv) Name a suitable tool that could be used to cut out the curved shapes of the coat hook.

..... [1]

(v) Name a suitable type of file that could be used to make the curved edge shown at **B** in Fig. 12.2 smooth.

..... [1]

(b) Fig. 12.3 shows details of the bend that needs to be made to the legs.

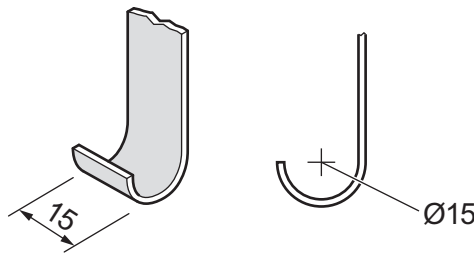

Fig. 12.3

Use sketches and notes to show how **one** of the legs could be bent to shape. Name all the tools and equipment used.

[4]



DO NOT WRITE IN THIS MARGIN



(c) Fig. 12.4 shows a screenshot of the outline shape of the coat hook drawn using CAD software. When using CAD, changes to a design can be made quickly and accurately.

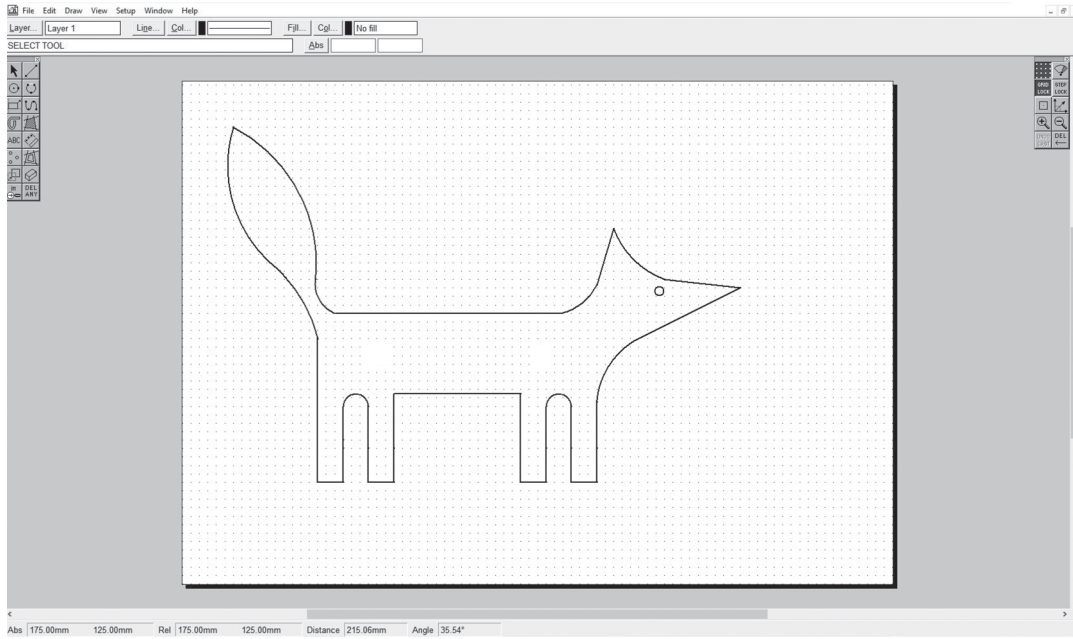

Fig. 12.4

(i) Give **three** additional ways the CAD drawing could be modified.

1 *Apply different colours to the outline shape*

2 .....

3 .....

4 .....

[3]

(ii) Give **two** benefits of using CAM to batch produce the coat hooks.

1 .....

2 .....

[2]



DO NOT WRITE IN THIS MARGIN



(d) Fig. 12.5 shows the coat hook that will be fixed to the wall using two screws.

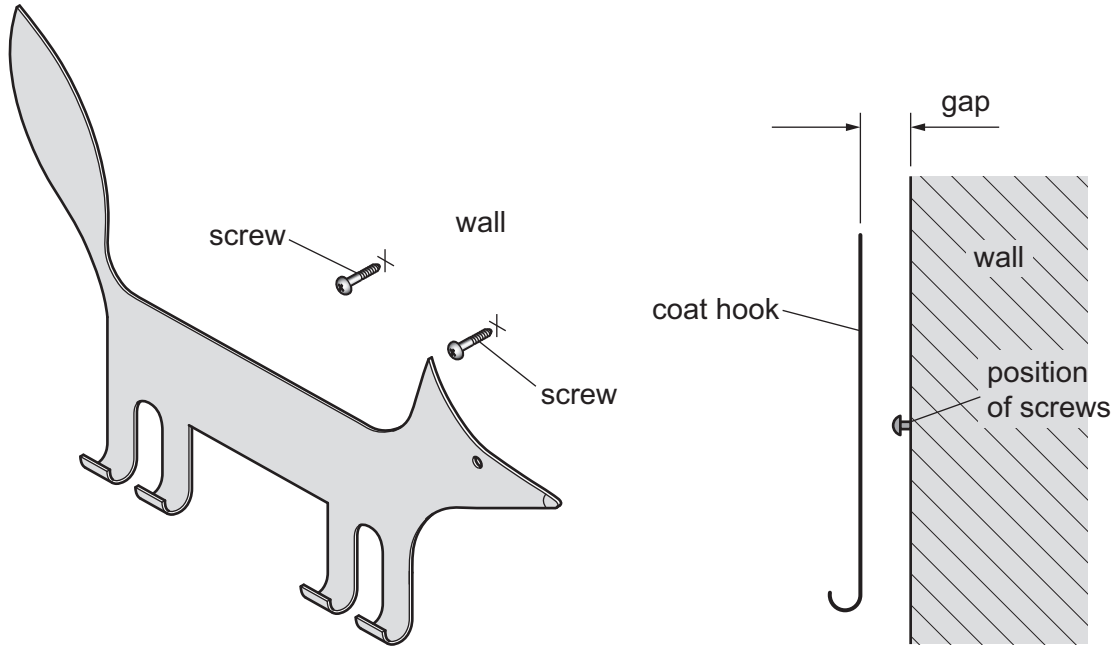

Fig. 12.5

Use sketches and notes to show a design for a bracket that will be attached to the back of the coat hook.  
The coat hook and bracket will then be fixed to the wall by the screws.  
Give details of all materials and constructions used.

DO NOT WRITE IN THIS MARGIN

DO NOT WRITE IN THIS MARGIN

DO NOT WRITE IN THIS MARGIN

DO NOT WRITE IN THIS MARGIN

DO NOT WRITE IN THIS MARGIN





(e) Paint could be applied to the coat hook to improve the appearance of the mild steel sheet.

(i) Name a suitable finish, **other** than paint, that could be applied to the mild steel sheet.

..... [1]

(ii) Describe how the surfaces of the mild steel sheet could be prepared to take an applied finish.

.....  
.....  
..... [2]

(f) The coat hook could be made from aluminium sheet.

Give **two** advantages of using aluminium rather than mild steel for the coat hook.

1 .....  
2 ..... [2]

DO NOT WRITE IN THIS MARGIN





13 Fig. 13.1 shows an incomplete design for a case to store and carry a selection of artist's materials and equipment.

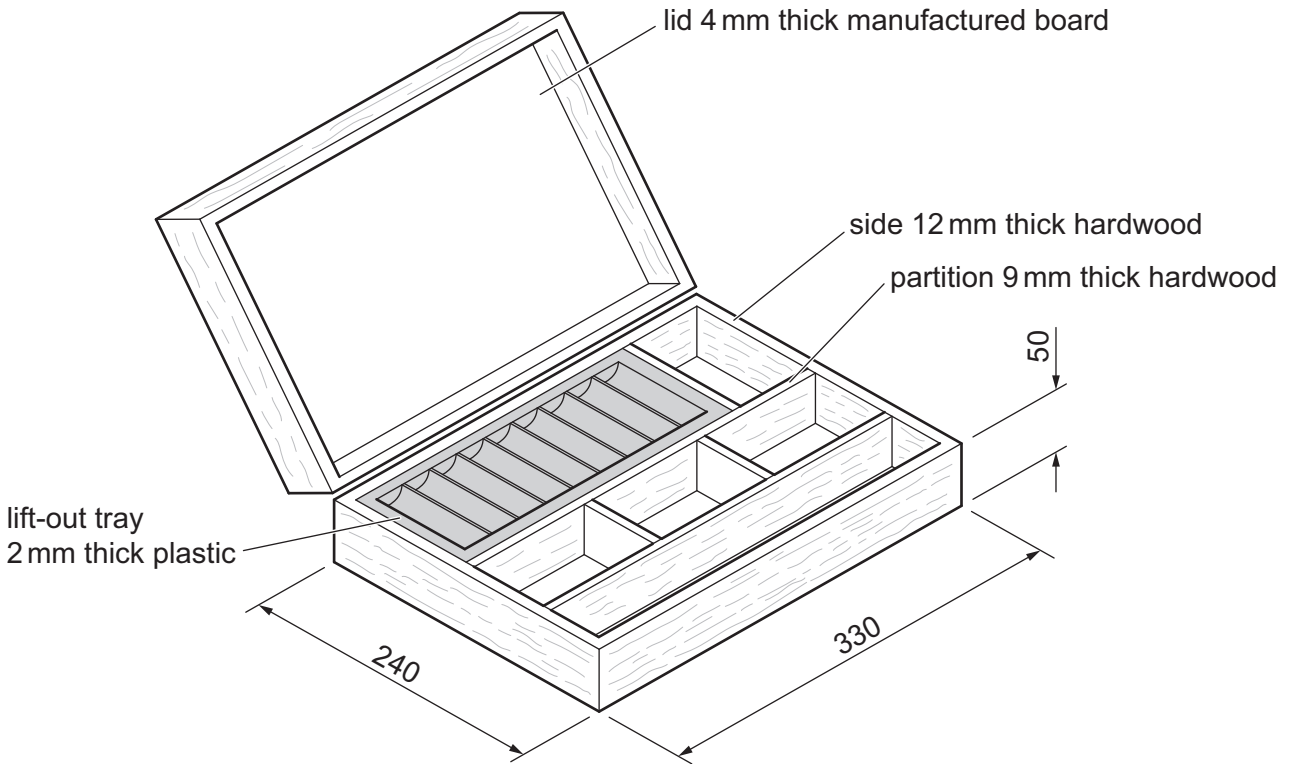

Fig. 13.1

(a) (i) Name a suitable hardwood for the sides of the case.

..... [1]

(ii) Name a suitable manufactured board for the lid.

..... [1]

(b) The sides of the case will be joined at each corner by means of a half lap joint. Add to Fig. 13.2 to show an exploded view of a half lap joint.

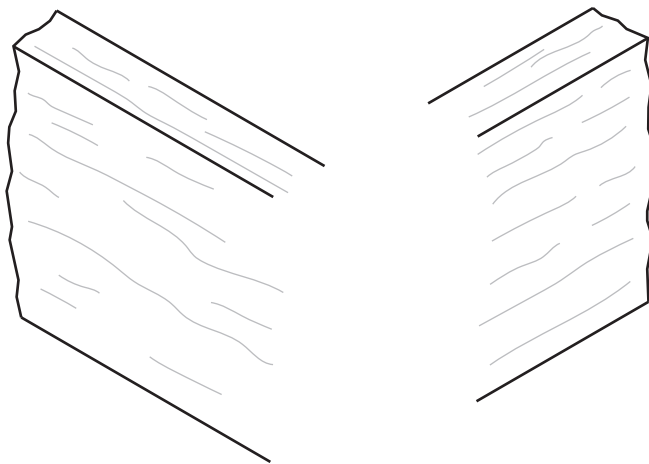

Fig. 13.2

[2]







(c) Fig. 13.3 shows details of the lift-out tray. The tray is made of a thermoplastic and produced by vacuum forming.

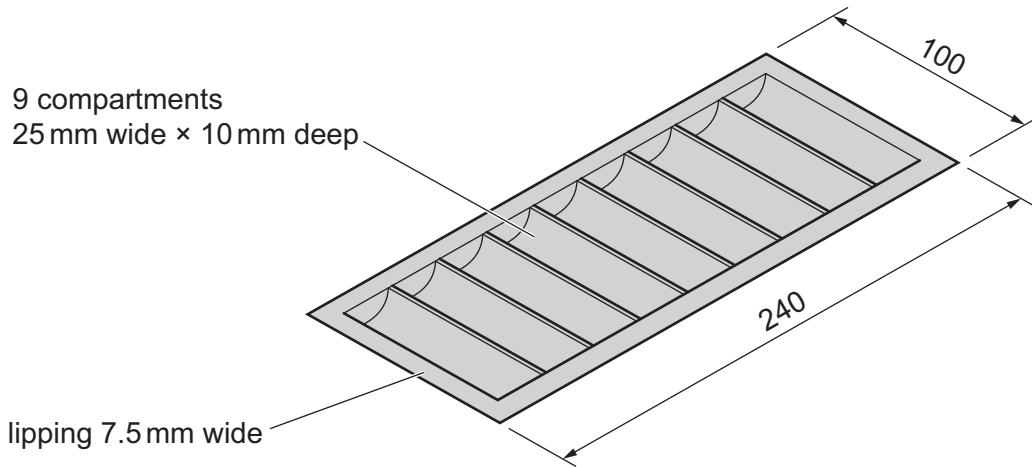

Fig. 13.3

(i) Use sketches and notes to show a design for a mould that could be used to vacuum form the lift-out tray.

[4]

(ii) Circle, from the list below, the most suitable material from which to make the mould.

- hardboard
- pine
- MDF
- chipboard
- oak

[1]



DO NOT WRITE IN THIS MARGIN



(d) Fig. 13.4 shows details of an artist's palette that will be stored inside the lid of the case. The palette is made from acrylic.

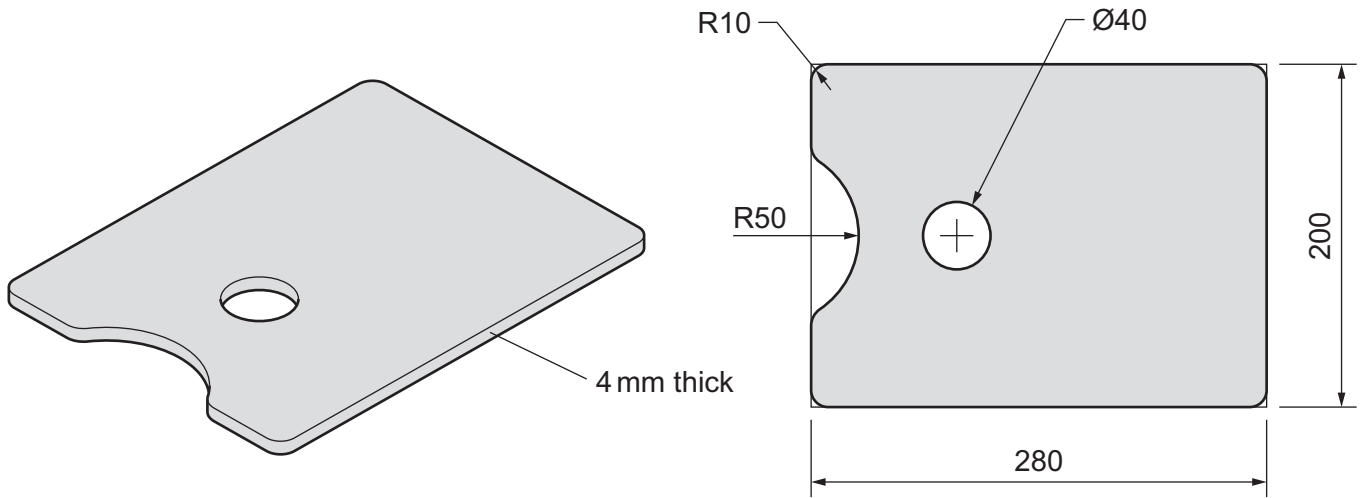

Fig. 13.4

(i) Use sketches and notes to show how the outline shape of the palette and the Ø40 hole could be cut out and the edges made smooth. Name all the tools and equipment used.

[4]





- (ii) When drilling acrylic sheet there is a danger that it could crack and break. Use sketches and notes to show how the danger could be overcome.

[2]

- (iii) Use sketches and notes to show how the palette could be stored securely inside the lid when the case is carried. The method of storage must allow for ease of access. Name any additional materials and fittings used.

[3]



DO NOT WRITE IN THIS MARGIN



- (e) Use sketches and notes to show a design for a handle that could be attached to the case to make it easier to carry.  
Name the material used to make the handle and show how it could be attached to the case.

[4]

DO NOT WRITE IN THIS MARGIN





(f) Fig. 13.5 shows details of one of two toggle catches that will be used to secure the lid to the base of the case. The toggle catch is shown in a closed position.

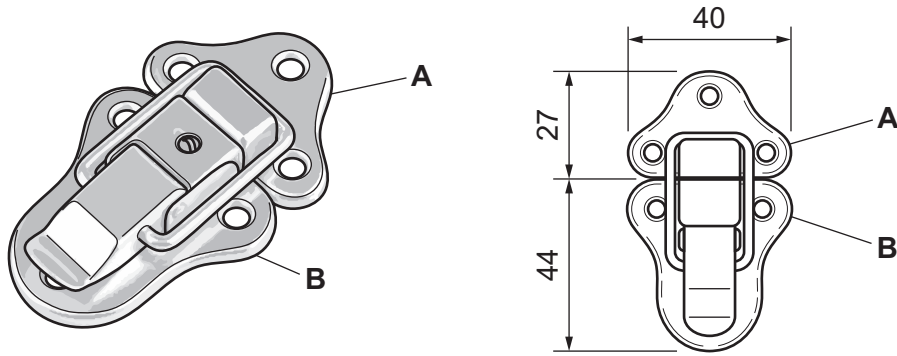

Fig. 13.5

Fig. 13.6 shows part of the lid and the base of the case. Add sketches to Fig. 13.6 to show parts **A** and **B** of the toggle catch in suitable positions on the lid and base of the case.

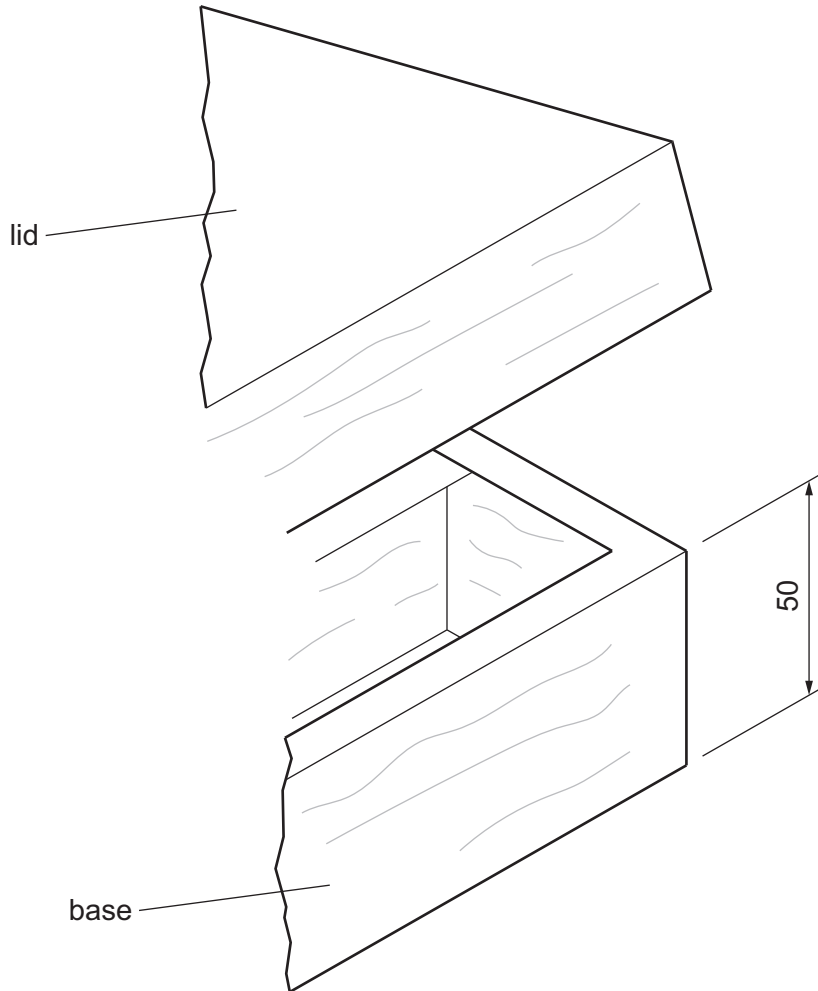

Fig. 13.6

[3]

DO NOT WRITE IN THIS MARGIN





BLANK PAGE

DO NOT WRITE IN THIS MARGIN

DO NOT WRITE IN THIS MARGIN

DO NOT WRITE IN THIS MARGIN

DO NOT WRITE IN THIS MARGIN

DO NOT WRITE IN THIS MARGIN



\* 000800000023 \*



23



BLANK PAGE

DO NOT WRITE IN THIS MARGIN





**BLANK PAGE**

DO NOT WRITE IN THIS MARGIN

DO NOT WRITE IN THIS MARGIN

DO NOT WRITE IN THIS MARGIN

DO NOT WRITE IN THIS MARGIN

DO NOT WRITE IN THIS MARGIN

---

Permission to reproduce items where third-party owned material protected by copyright is included has been sought and cleared where possible. Every reasonable effort has been made by the publisher (UCLES) to trace copyright holders, but if any items requiring clearance have unwittingly been included, the publisher will be pleased to make amends at the earliest possible opportunity.

To avoid the issue of disclosure of answer-related information to candidates, all copyright acknowledgements are reproduced online in the Cambridge Assessment International Education Copyright Acknowledgements Booklet. This is produced for each series of examinations and is freely available to download at [www.cambridgeinternational.org](http://www.cambridgeinternational.org) after the live examination series.

Cambridge Assessment International Education is part of Cambridge Assessment. Cambridge Assessment is the brand name of the University of Cambridge Local Examinations Syndicate (UCLES), which is a department of the University of Cambridge.

