

Section A

Answer all questions in this section.

1 Give two pieces of information required when buying woodscrews.

- 1 Length ✓
- 2 Type of Screw head ✓

[2]

2 A list of materials is given below.

- brass CFRP copper polycarbonate stainless steel

Select from the list one material that is:

- (a) an alloy brass ✓ [1]
- (b) a composite CFRP ✓ [1]

3 Complete the drawing below to show an exploded view of a corner halving joint.

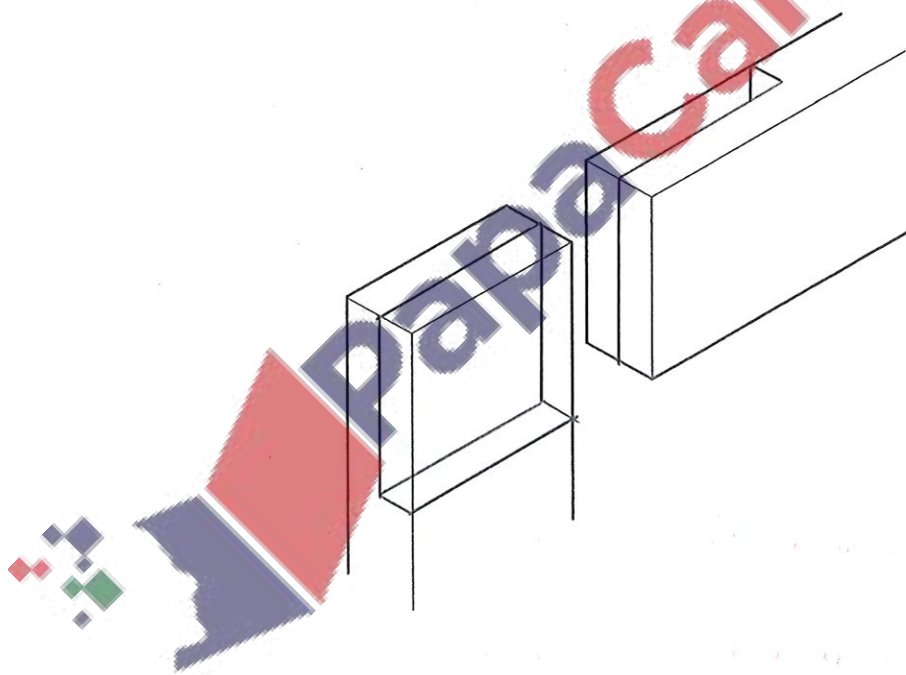



[3]

7

4 Complete Table 4.1 by naming a suitable material for each product.

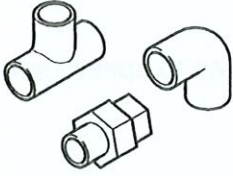
Table 4.1

Product	Suitable material
 plastic chair	ABS ✓
 metal water pipe fittings	Brass ✓
 wooden model glider	Balsa wood ✓

[3]

3

[Turn over

- 5 Fig. 5.1 shows a coat hook for a child. The coat hook is made from 5 mm thick acrylic and will be batch produced.

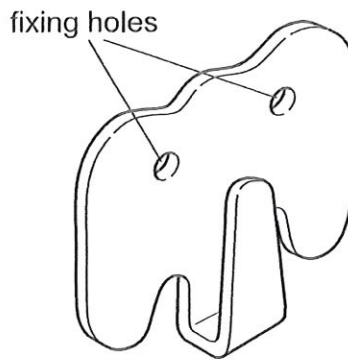

Fig. 5.1

Complete Table 5.1 by stating how each item could be used to speed up batch production of the coat hook.

Table 5.1

Item	How each item is used to speed up production
Template	To quickly and accurately mark out the acrylic ✓
Former	To bend the hook accurately and repeatably ✓
Drilling jig	To drill at the same location accurately every time and aligns the drilling bit ✓

[3]

- 6 Table 6.1 shows two items of equipment used with a centre lathe. Complete Table 6.1 by stating the name of each item of equipment.

Table 6.1

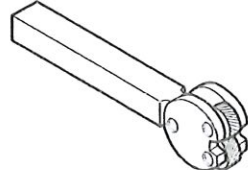
Item of equipment	Name
	Chuck ✓
	Knurling tool ✓

[2]

5

- 7 Fig. 7.1 shows the end of a mild steel strip marked out, ready to be shaped.

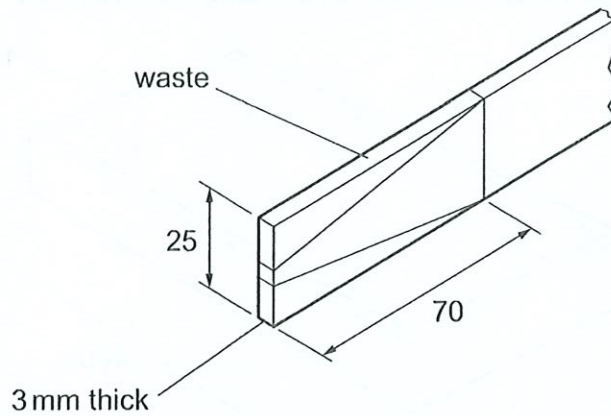

Fig. 7.1

Name the hand tool used to:

- (a) mark out the lines Scribe ✓ [1]
- (b) saw off the waste metal Hacksaw ✓ [1]
- (c) make the sawn edge flat and smooth Hand file ✓ [1]

- 8 Explain **one** advantage of using Computer Numerically Controlled (CNC) machines compared with manually operated machines for batch production.

There is less skill required from the workers because workers only need to know how to start up and set up the machine, which manually operated machines require workers to know how to properly control the machine. ✓ [2]

5

- 9 Fig. 9.1 shows a box made from softwood. The box will have a base made from 4 mm thick manufactured board.

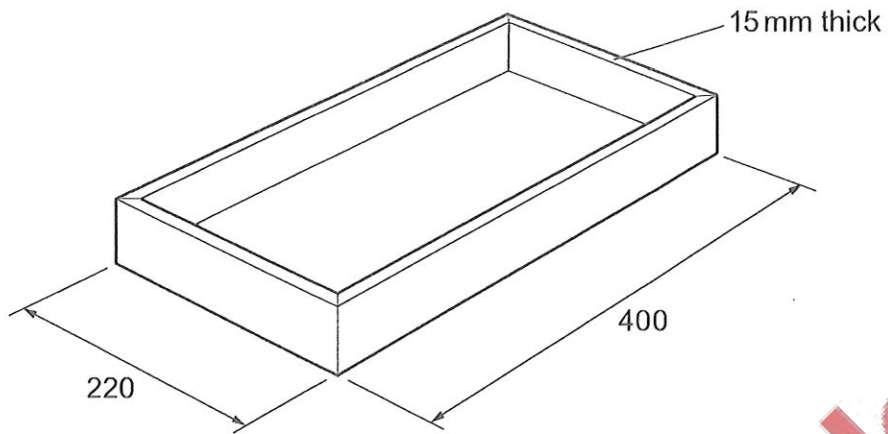
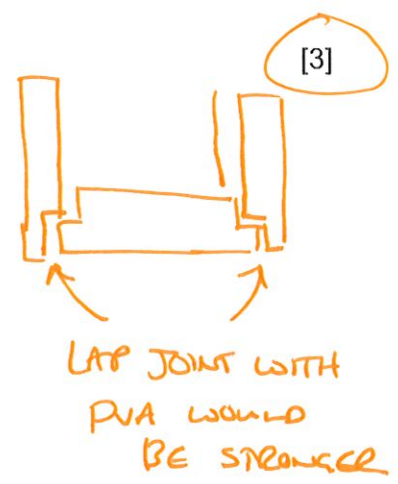
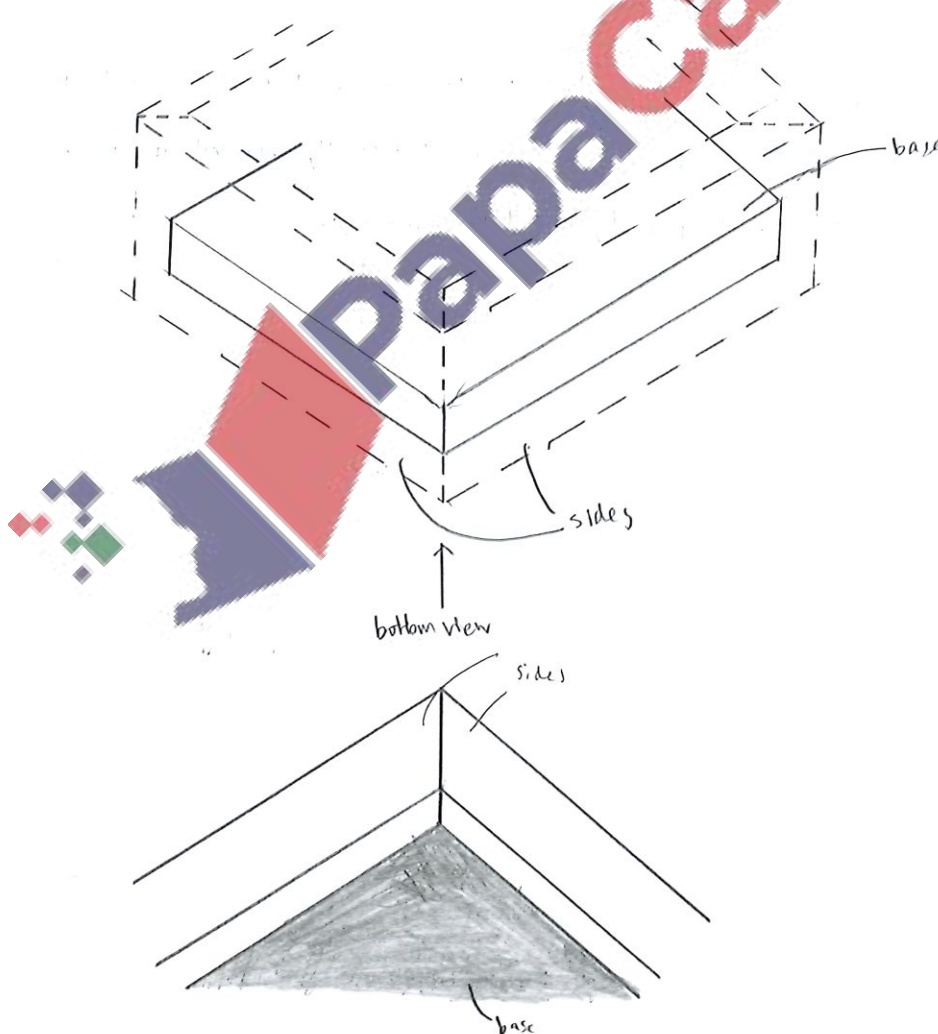

Fig. 9.1

Use sketches and notes to show how the base could be fitted inside the box so that the edges of the base are not seen.



3

10 Fig. 10.1 shows a plastic cup used for hot drinks.

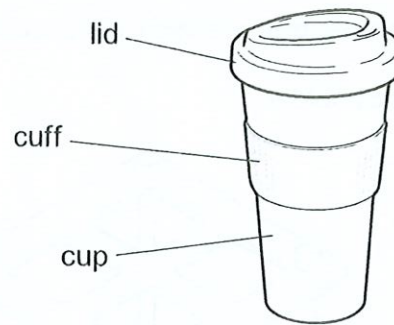
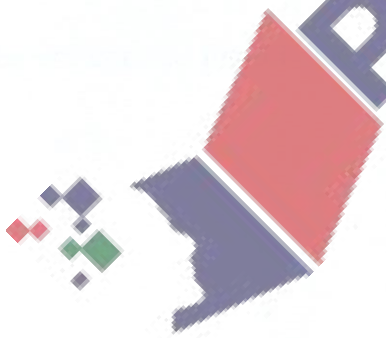

Fig. 10.1

Explain how the designer of the cup has considered the needs of the user.

The cuff has been added as an insulation so the user can hold the cup without being burned and also give a better grip. The lid is added to preserve the temperature of the drink and the cup is in a V like slanted cylinder (cone like shape) to let the customer user easily hold it. [2]



2

Section B

Answer one question in this section.

11 Fig. 11.1 shows a pen and pencil holder.

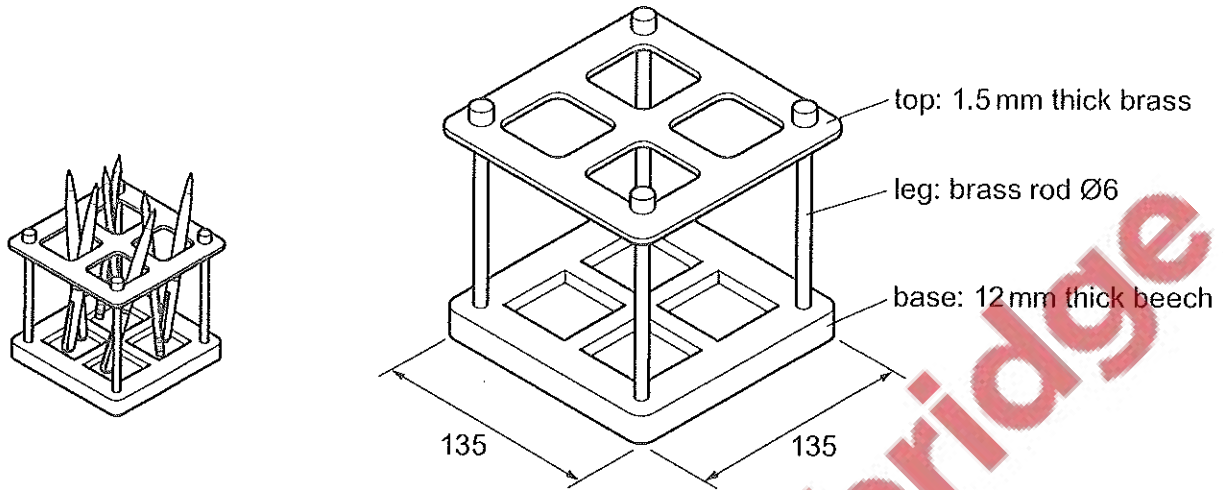

Fig. 11.1

(a) Fig. 11.2 shows the top part of the pen and pencil holder with the four shapes marked out.

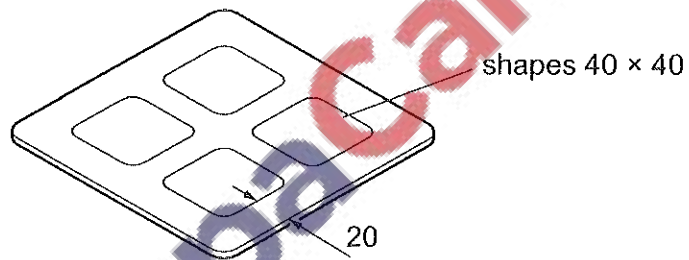
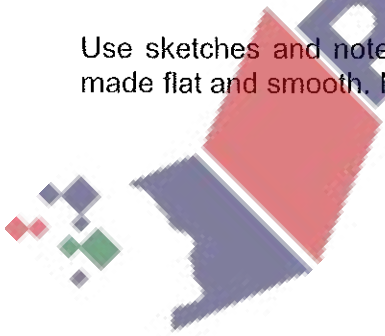

Fig. 11.2

Use sketches and notes to show how **one** of the shapes could be cut out and the edges made flat and smooth. Name all the tools and equipment used.



- (b) Fig. 11.3 shows how the legs are fitted to the top of the pen and pencil holder by means of screw threads.

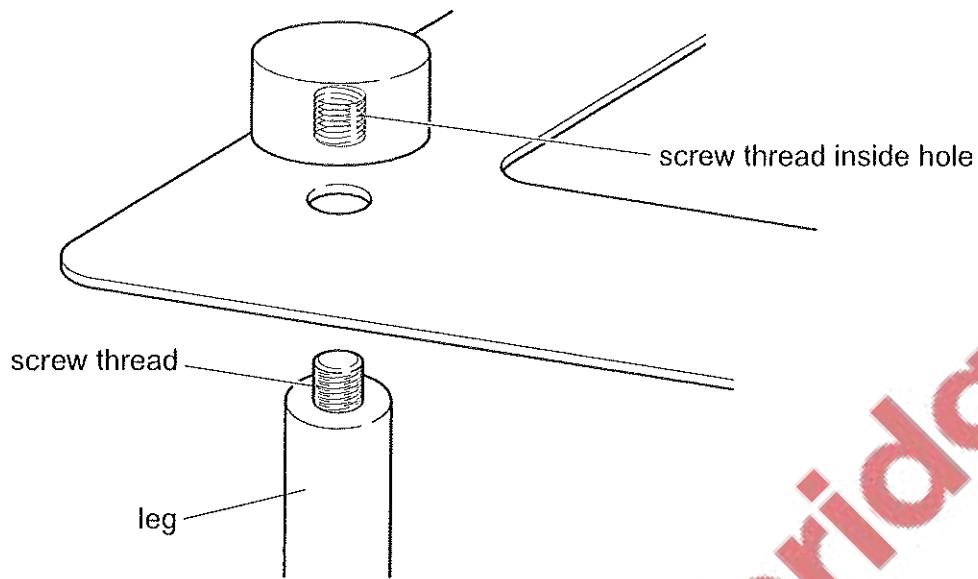

Fig. 11.3

- (i) Name the tool that could be used to cut the screw thread:

on the end of the leg

.....

inside the hole.

.....

[2]

- (ii) The screw thread could be replaced by a permanent method of fixing.

Circle from the list below a suitable permanent method of joining the legs to the top of the pen and pencil holder.

welding

brazing

soldering

[1]

- (f) Fig. 11.6 shows part of a length of acrylic tube from which the five tubes will be sawn to length.

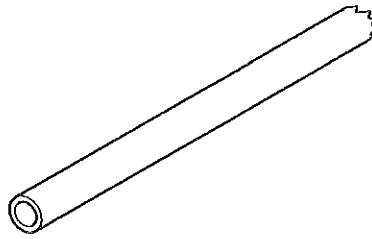

Fig. 11.6

- (i) Name a suitable saw that could be used to cut the acrylic tube to length.
..... [1]

- (ii) Use sketches and notes to show a design for a sawing jig.
The jig must:
- hold the tube securely
 - enable **five** different lengths, 50, 80, 90, 100 and 120 mm, to be sawn accurately.

PapaCambridge

- (g) The tubes will be joined to the base using acrylic cement.
Acrylic cement gives off toxic fumes.
Describe **two** ways by which the danger from toxic fumes can be safely reduced.

- 1
- 2

[4]

[2]

12 Fig. 12.1 shows an incomplete design for a storage box made from wood.

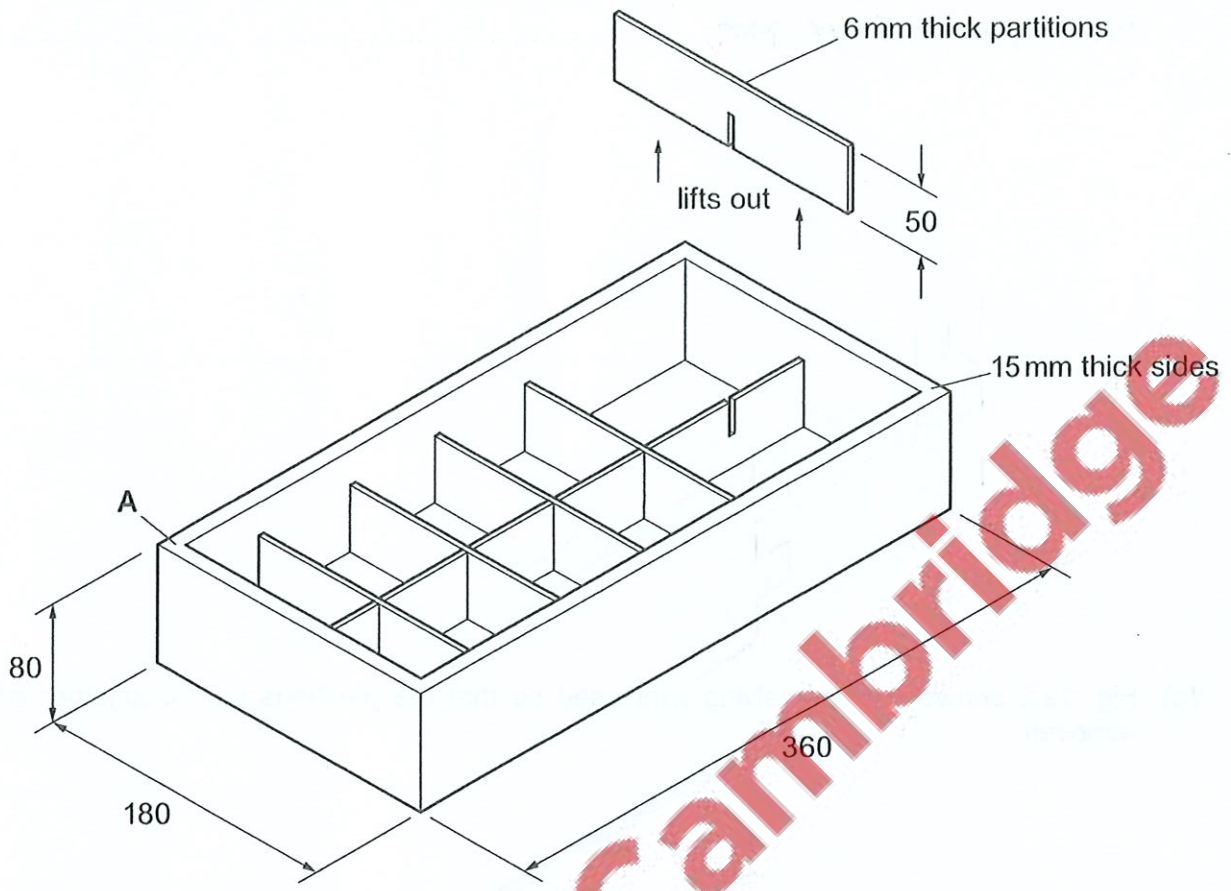

Fig. 12.1

(a) Complete Table 12.1 by adding the missing dimensions of the parts.

Table 12.1

Part	Number required	Length × Width × Thickness	Material
Long side	2	360 × 80 × 15	beech
Short side	2	180 × 80 × 15	beech
Base	1	360 × 180 × 6	plywood
Long partition	1	336 × 50 × 6	plywood
Short partition	5	150 × 50 × 6	plywood

(4)

3

(b) Name and sketch a permanent joint that could be used at corner A.

Name of joint Finger joint ✓

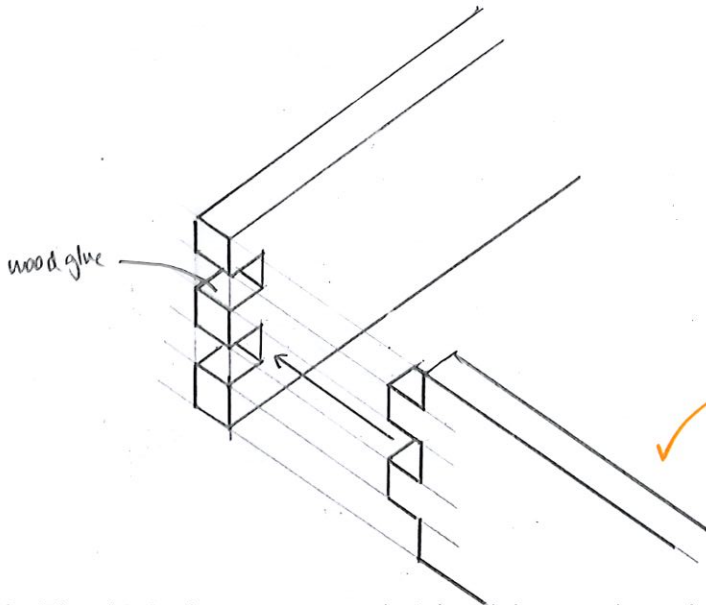

[4]

(c) Fig. 12.2 shows a cross-halving joint used so that the partitions can fit together and be removed.

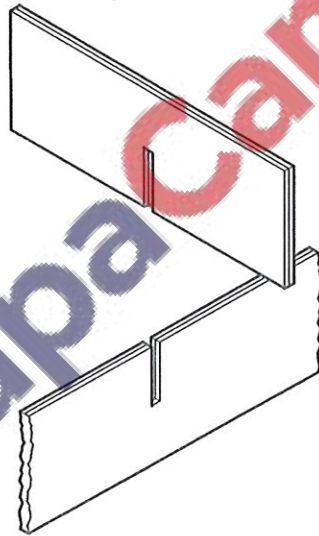

Fig. 12.2

(i) Name two different saws that could be used to cut out the cross-halving joint.

1 Tenon saw ✓

2 Mitre saw x band saw scroll saw coping saw

[2]

(ii) Give two advantages, other than cost, of making the partitions from plywood rather than beech.

1 Plywood does not warp as much ✓

2 Plywood is stronger in all directions ✓

[2]

7

- (d) Use sketches and notes to show a different method of keeping items separate inside a storage box.

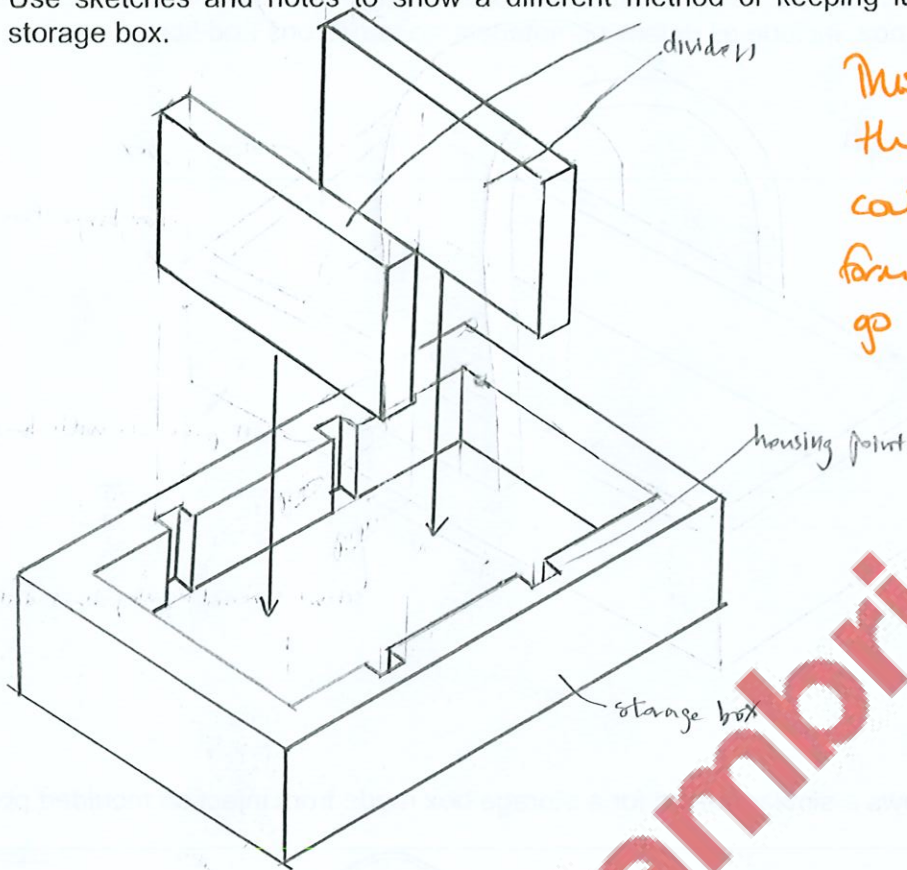

This is similar to the original. You could have vacuum formed a tray to go inside the box.

[3]

- (e) To complete the design of the storage box in Fig. 12.1 modifications need to be made.

- (i) Use sketches and notes to show a design for a lid that could be fitted to the storage box. Include all details of materials, constructions and fittings used.

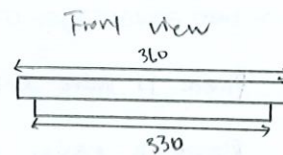
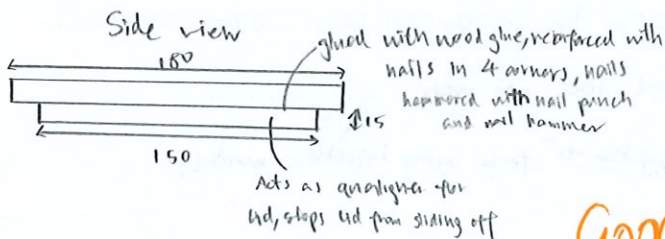
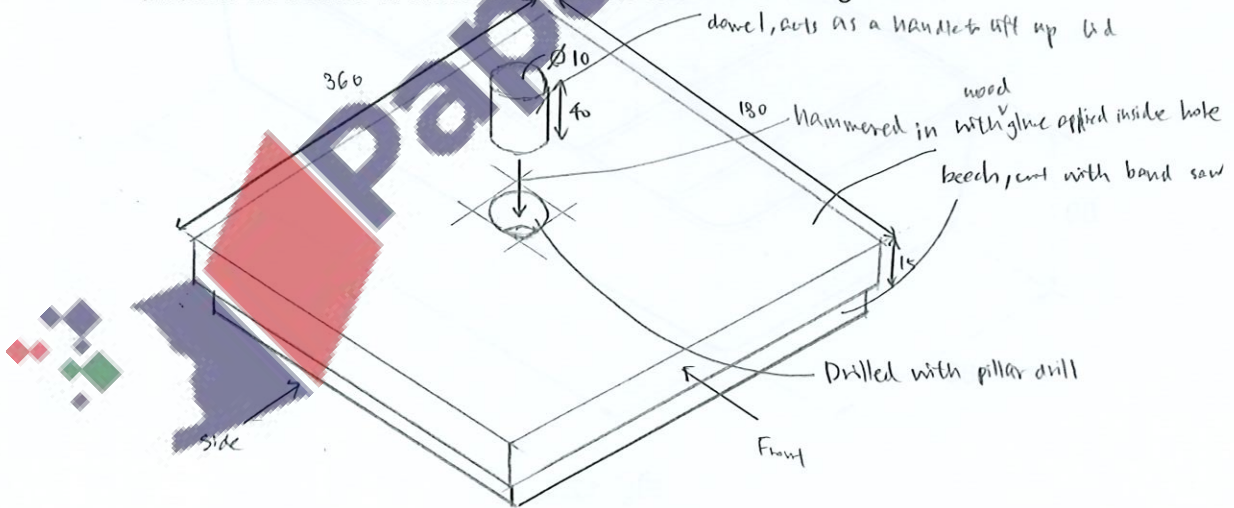

Good!

[5]

8

(ii) Use sketches and notes to show a modification that would make it easier to carry the storage box. Include all details of materials, constructions and fittings used.

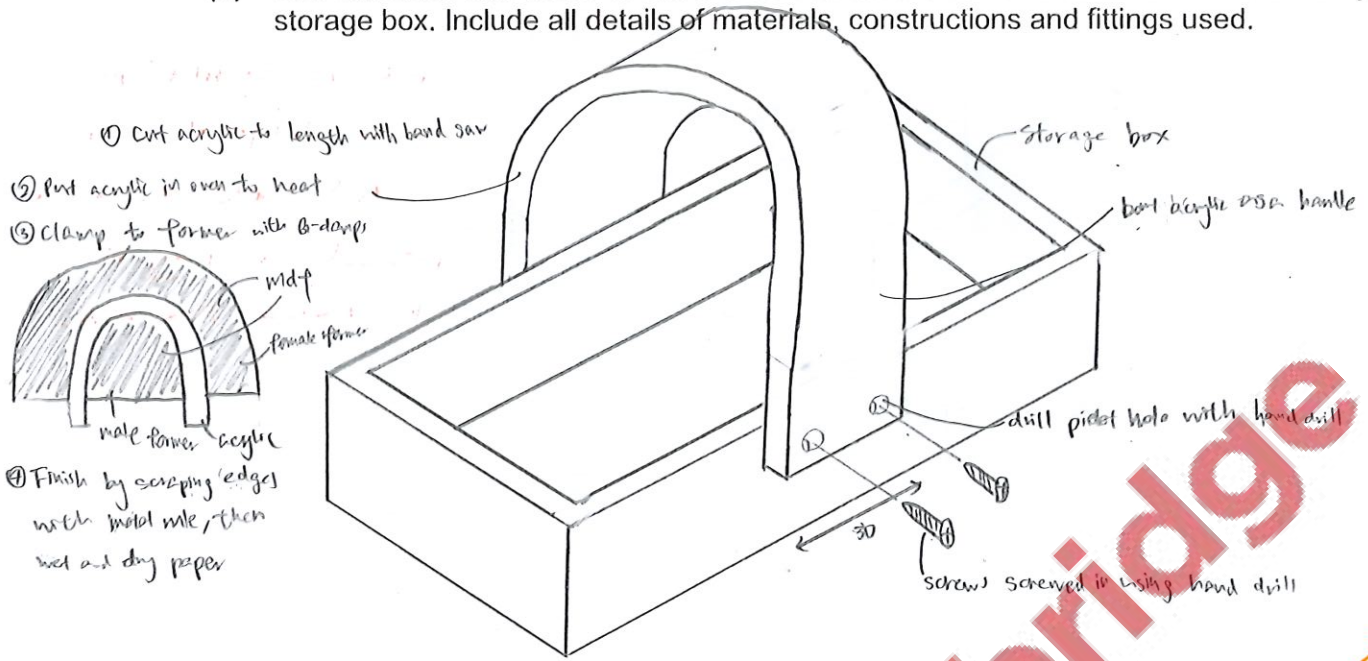

[3]

(f) Fig. 12.3 shows a similar design for a storage box made from injection moulded plastic.

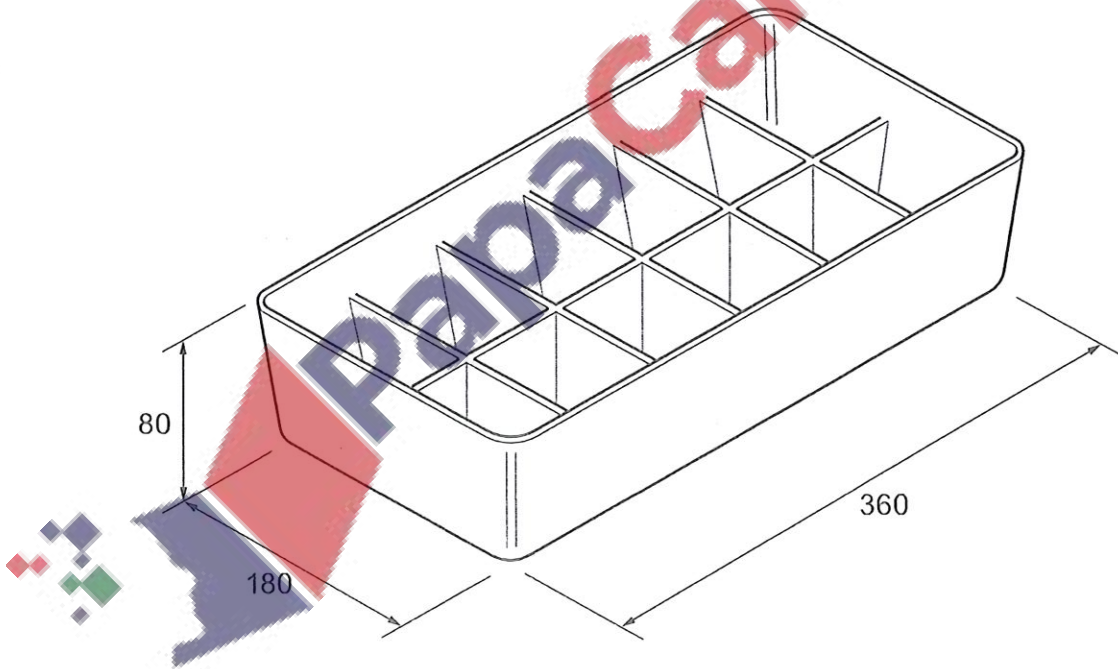

Fig. 12.3

Give two advantages of making the storage box from plastic rather than wood.

- 1 ... Plastic is more durable and does not warp.
- 2 ... Plastic is easier and quicker to form using injection moulding.

[2]

5

- 13 Fig. 13.1 shows wind chimes that will be batch produced in a school workshop. All the production methods require speed and accuracy.

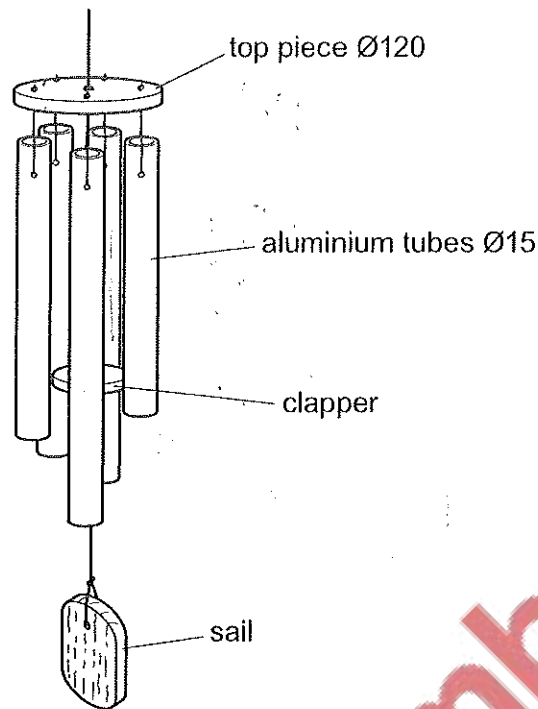

Fig. 13.1

- (a) Give **two** advantages of using a non-ferrous metal such as aluminium for the tubes rather than a ferrous metal.

1

2

[2]

- (b) (i) Use sketches and notes to show a design for an adjustable sawing jig that could be used to cut five different lengths of tube to the following sizes: 300, 280, 250, 240 and 220 mm. Name the materials used to make the sawing jig.



[4]

[Turn over

- (ii) Describe how a centre lathe could be used to produce a flat and smooth finish to the sawn ends of the aluminium tubes.

.....

.....

.....

.....

..... [3]

(c) The aluminium tubes will have a lacquered finish.

- (i) Name an abrasive paper that could be used to prepare the surface of the aluminium tubes.

..... [1]

- (ii) Name a machine that could be used to produce a high quality finish on the aluminium tubes after abrasive paper has been used.

..... [1]

- (iii) State a method of applying lacquer quickly and evenly.

..... [1]

(d) Fig. 13.2 shows a block of wood that will be used to make the top piece of the wind chimes. The shape of the top piece has been marked out and will be produced on a woodturning lathe.

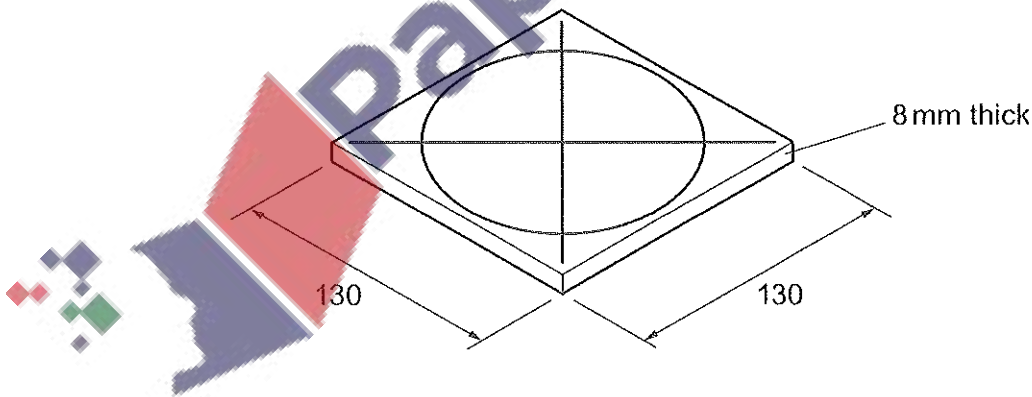

Fig. 13.2

- (i) Circle from the list below two methods of woodturning that could be used to produce the top piece of the wind chimes.

parallel between-centres taper faceplate centre

[2]

- (ii) Use sketches and notes to show a different method of producing the shape for the top piece of the wind chimes.

[3]

- (e) Describe **two** quality control checks that could be carried out at any stage during the batch production of the wind chimes.

1

.....

2

.....

[4]

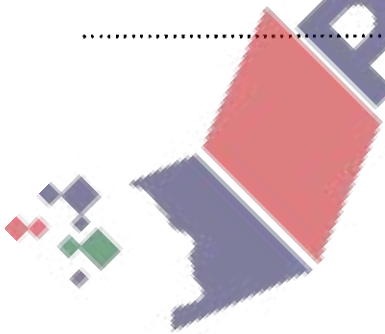

Papa Cambridge

- (f) The wind chimes will be suspended from a bracket.
Fig. 13.3 shows part of the wind chimes.

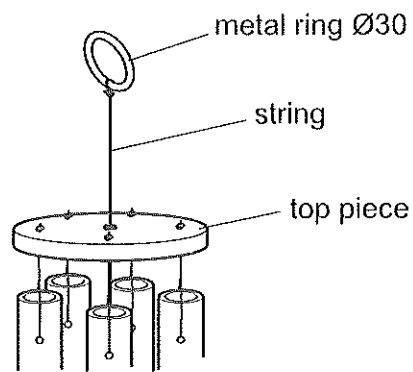

Fig. 13.3

Use sketches and notes to design a bracket from which the wind chimes could be suspended.

The bracket must:

- be able to be fixed to a wall
- hold the wind chimes securely.

Include details of all materials and constructions used.

