

# Mass & Weight

## Question Paper 1

Level	IGCSE
Subject	Physics (0625/0972)
Exam Board	Cambridge International Examinations (CIE)
Topic	General Physics
Sub-Topic	Mass & Weight
Booklet	Question Paper 1

**Time allowed:** 18 minutes

**Score:** /14

**Percentage:** /100

### Grade Boundaries:

9	8	7	6	5	4	3	2	1
>85%	75%	68%	60%	55%	50%	43%	35%	<30%

## Question 1

A cup contains hot liquid.

Some of the liquid evaporates.

What happens to the mass and what happens to the weight of the liquid in the cup?

	mass	weight
A	decreases	decreases
B	decreases	stays the same
C	stays the same	decreases
D	stays the same	stays the same

## Question 2

An astronaut in an orbiting spacecraft experiences a force due to gravity. This force is less than when she is on the Earth's surface.

Compared with being on the Earth's surface, how do her mass and her weight change when she goes into orbit?

	mass in orbit	weight in orbit
A	decreases	decreases
B	decreases	unchanged
C	unchanged	decreases
D	unchanged	unchanged

### Question 3

Diagram 1 shows a piece of foam rubber that contains many pockets of air. Diagram 2 shows the same piece of foam rubber after it has been compressed so that its volume decreases.

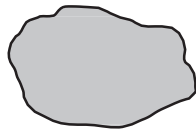

diagram 1  
(before compression)

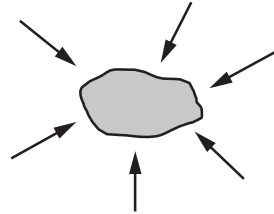

diagram 2  
(after compression)

What happens to the mass and to the weight of the foam rubber when it is compressed?

	mass	weight
A	increases	increases
B	increases	no change
C	no change	increases
D	no change	no change

## Question 4

Weight is an example of which quantity?

- A. acceleration
- B. force
- C. mass
- D. pressure

## Question 5

The mass of an object is measured on Earth. The mass is 5.0 kg.

The object is taken to the Moon. The mass of the object is measured on the Moon.

What is the mass of the object on the Moon?

- A. 0 kg
- B. more than 0 kg, but less than 5.0 kg
- C. 5.0 kg
- D. more than 5.0 kg

## Question 6

Which statement about mass or weight is correct?

- A. Mass is a force.
- B. Mass is measured in newtons.
- C. Weight is a force.
- D. Weight is measured in kilograms.

## Question 7

What is the weight of an object?

- A. the force of gravity on the object
- B. the gravitational potential energy of the object
- C. the internal energy of the object
- D. the mass of the object



## Question 8

Which instrument is used to compare the masses of objects?

- A. a balance
- B. a barometer
- C. a manometer
- D. a measuring cylinder

## Question 9

A customer goes to a market and buys some rice. The stallholder pours rice into a dish that hangs from a spring balance. He records the reading on the spring balance.

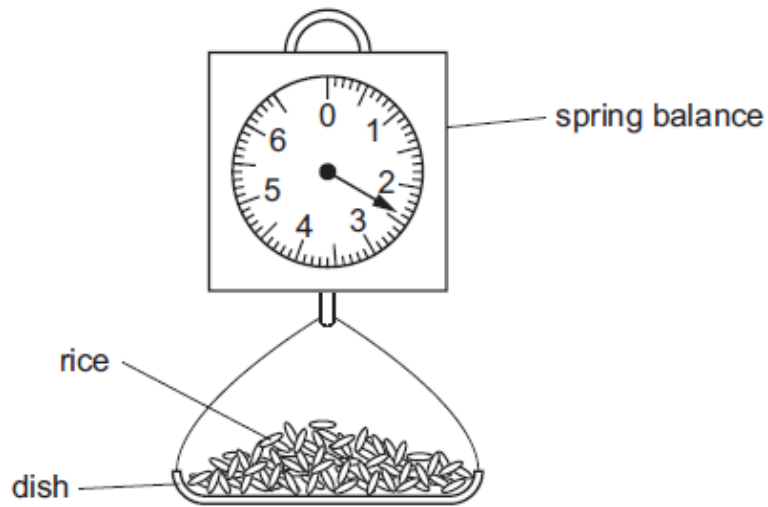

The customer then buys some pasta and the stallholder notices that the reading on the spring balance, with just pasta in the dish, is the same as it was with just rice in the dish.

The rice and the pasta must have the same

- A. density.
- B. temperature.
- C. volume.
- D. weight.

## Question 10

The mass of an astronaut is 70kg on the Moon.

What is the mass of the astronaut on the Earth?

- A 7 kg                      B 70 kg                      C 80 kg                      D 700 kg

## Question 11

The weight of an object is found using the balance shown in the diagram. The object is put in the left-hand pan and various weights are put in the right-hand pan.

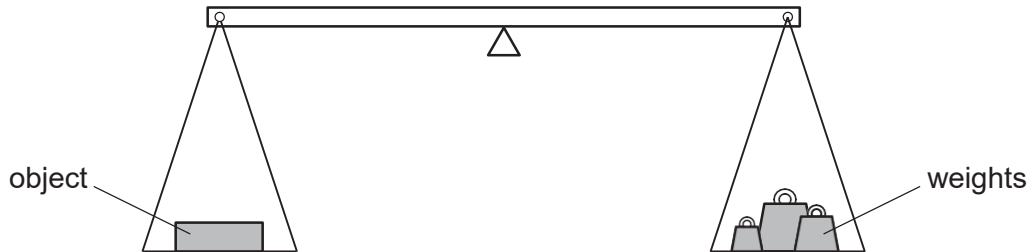

These are the results.

weights in the right-hand pan	effect
0.1 N, 0.1 N, 0.05 N, 0.02 N	balance tips down slightly on the left-hand side
0.2 N, 0.1 N, 0.01 N	balance tips down slightly on the right-hand side

What is the best estimate of the weight of the object?

- A 0.27 N      B 0.29 N      C 0.31 N      D 0.58 N

## Question 12

Which is the unit for force and which is the unit for weight?

	force	weight
A	kg	kg
B	kg	N
C	N	kg
D	N	N

## Question 13

Which quantity is measured in newtons?

- A. density
- B. energy
- C. pressure
- D. Weight.

## Question 14

A geologist places a small rock on the left-hand pan of a balance. The two pans are level as shown when masses with a total weight of 23 N are placed on the right-hand pan. Take the weight of 1.0 kg to be 10 N.

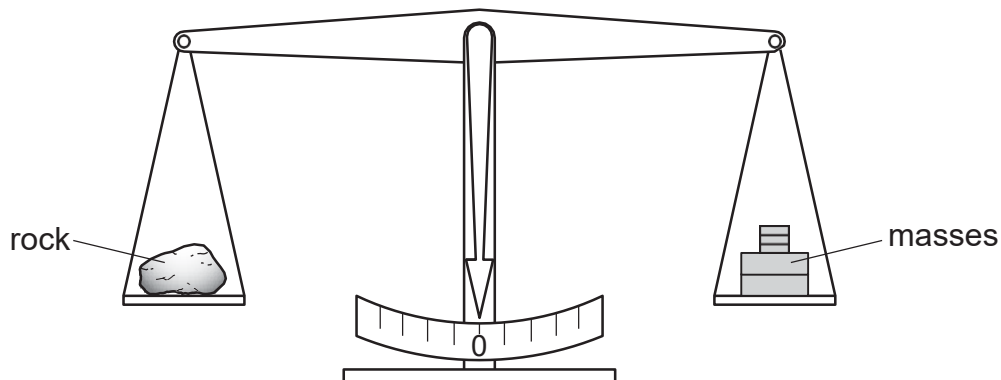

What is the mass of the small rock?

- A 0.023kg      B 2.3kg      C 23kg      D 230kg