

date

Centre Number

|  |
|--|
|  |
|--|

Candidate Name \_\_\_\_\_

**International General Certificate of Secondary Education**  
**CAMBRIDGE INTERNATIONAL EXAMINATIONS**  
**COMBINED SCIENCE**  
**PAPER 2**

**0653/2**

**OCTOBER/NOVEMBER SESSION 2002**

1 hour

Candidates answer on the question paper.  
No additional materials are required.

**TIME** 1 hour

**INSTRUCTIONS TO CANDIDATES**

Write your name, Centre number and candidate number in the spaces at the top of this page.

Answer **all** questions.

Write your answers in the spaces provided on the question paper.

**INFORMATION FOR CANDIDATES**

The number of marks is given in brackets [ ] at the end of each question or part question.

A copy of the Periodic Table is printed on page 16.

| FOR EXAMINER'S USE |  |
|--------------------|--|
| 1                  |  |
| 2                  |  |
| 3                  |  |
| 4                  |  |
| 5                  |  |
| 6                  |  |
| 7                  |  |
| 8                  |  |
| 9                  |  |
| <b>TOTAL</b>       |  |

- 1 In the circuit diagram shown in Fig. 1.1, the brightness of the lamp can be controlled by a variable resistor.

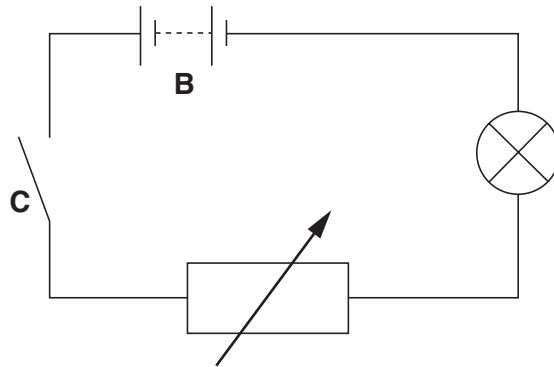

Fig. 1.1

- (a) Name components **B** and **C**.

**B** .....

**C** .....[2]

- (b) Redraw the circuit diagram to show how you would include an ammeter in the circuit to measure the current flowing through the lamp.

[2]

- (c) State the unit in which electric current is measured.

.....[1]

(d) State **two** electrical dangers that are visible in Fig. 1.2.

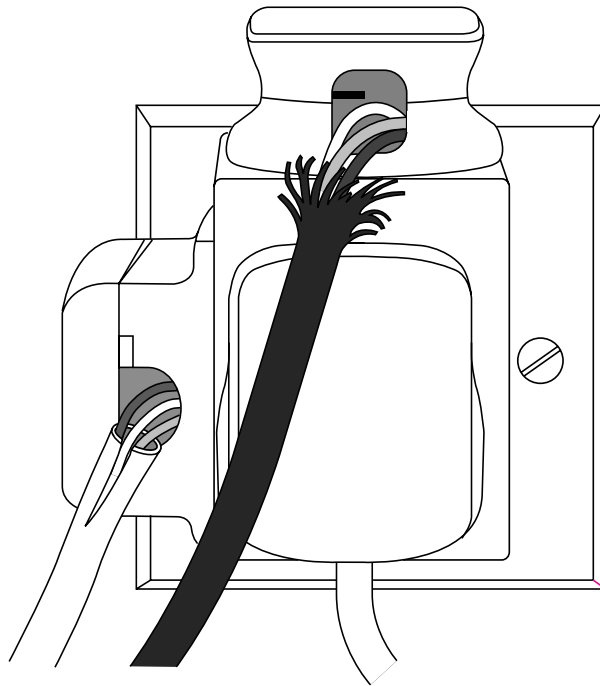

Fig. 1.2

danger 1 .....

.....

danger 2 .....

.....[2]

- 2 A student investigated the activity of the enzyme catalase, which is present in animal tissues. This enzyme catalyses the break-down of hydrogen peroxide to water and oxygen

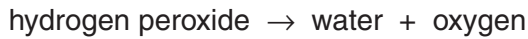

She put equal volumes of hydrogen peroxide into two small flasks. She took two pieces of fresh liver of equal mass, and cut one of them into small pieces. Then she placed each flask onto a balance and added the whole piece of liver to one flask and the small pieces of liver to the other. She read the mass of each flask every 30 seconds for five minutes. Fig. 2.1 shows her results.

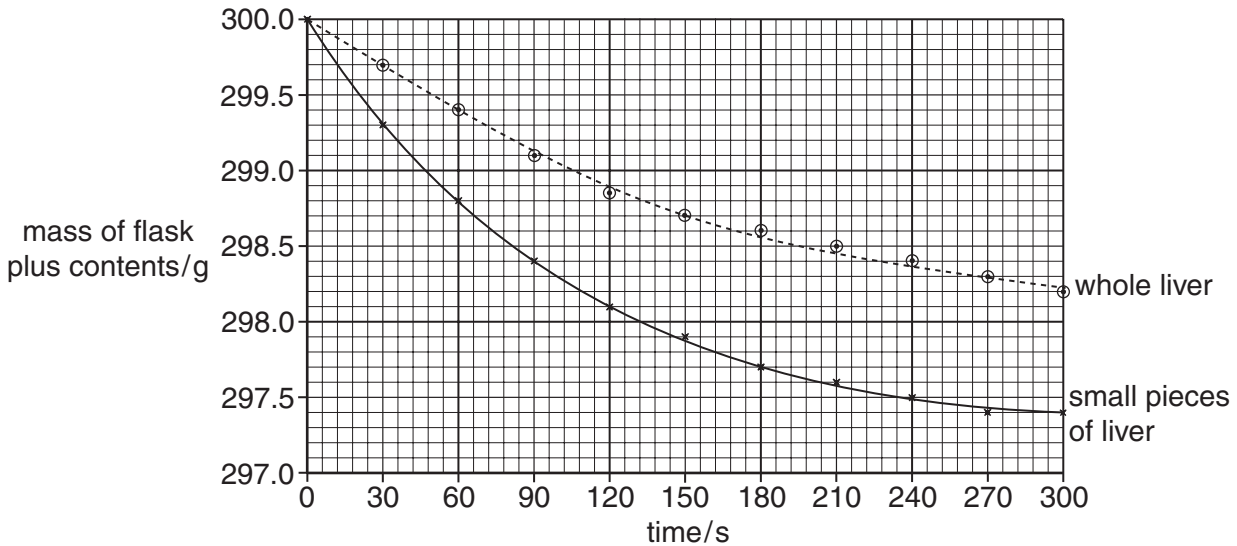

Fig. 2.1

- (a) Use the word equation above to explain why the mass of each flask and its contents decreased.

.....  
 .....  
 .....[2]

- (b) Explain why the mass of one flask and its contents decreased more rapidly than the other.

.....  
 .....  
 .....[2]

- (c) Predict the results that would be obtained if the liver was placed in boiling water for a few minutes before adding it to hydrogen peroxide. Explain your prediction.

.....  
 .....  
 .....[2]

- 3 Fig. 3.1 shows four sets of apparatus **P**, **Q**, **R** and **S** which are used to separate mixtures. The diagrams are not drawn to scale.

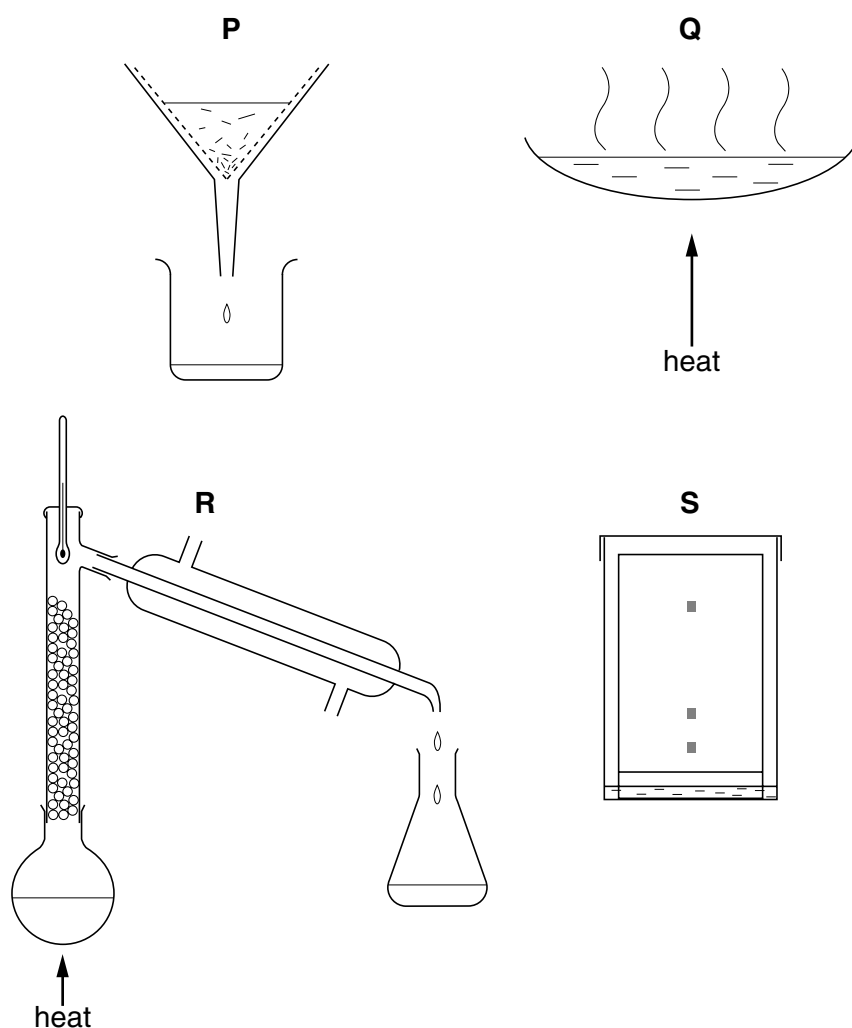

Fig. 3.1

- (a) State which apparatus, **P**, **Q**, **R** or **S** is normally used to separate
- the solid from a solid dissolved in a liquid, .....
- the solid from an insoluble solid suspended in a liquid, .....
- three differently coloured solids dissolved in a liquid. .... [3]
- (b) (i) Which of the diagrams **P**, **Q**, **R** or **S** in Fig. 3.1 shows apparatus used for fractional distillation? .....[1]
- (ii) Explain why fractional distillation is an important process in the oil industry.  
.....  
.....  
..... [2]



4 (a) (i) Describe how sound is produced when an object is hit.

.....

(ii) Explain how a sound can be heard some distance away from where it was produced.

.....

.....

.....[2]

(b) Two astronauts walking on the Moon cannot talk directly to each other. They have to speak to each other by radio. Explain why this is so.

.....

.....

.....[2]

- 5 Fig. 5.1 shows a plant.

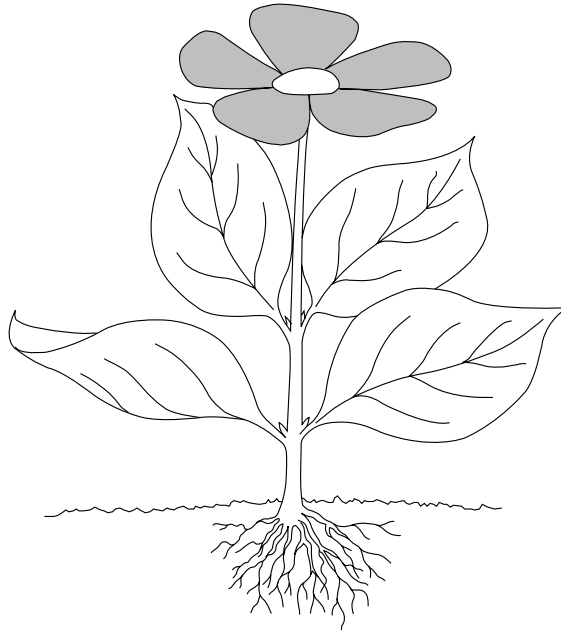

**Fig. 5.1**

- (a) On Fig. 5.1, draw a label line to each of the following parts, and label each one with the appropriate letter.

**P** a place where water enters the plant.

**Q** the part of the plant that is responsible for sexual reproduction. [2]

- (b) The palisade cells in the leaves of the plant are responsible for photosynthesis. In photosynthesis, energy from sunlight is used to make carbon dioxide and water react together to produce glucose and oxygen.

(i) Name the substance, present in the palisade cells, that traps sunlight energy.

.....[1]

(ii) Describe what happens to the glucose if the plant makes more than it immediately needs.

.....

.....

.....[2]

- (c) A leafy shoot was cut from a plant, and placed with its cut end in a solution of a red dye. After an hour, red lines could be seen in the leaves.

Explain how this happened.

.....

.....

6 Poly(ethene) is a material used to make plastic articles. Poly(ethene) is made from the hydrocarbon ethene.

(a) (i) Explain the meaning of the term *hydrocarbon*.

.....  
.....[2]

(ii) Explain why a molecule of poly(ethene) has a much higher mass than a molecule of ethene.

.....  
.....  
.....[2]

(b) A student is heating a sample of poly(ethene) when it catches fire. She covers the burning poly(ethene) with a damp cloth.

Explain why this action puts the fire out.

.....  
.....  
.....[2]



7 Fig. 7.1 shows the male reproductive system.

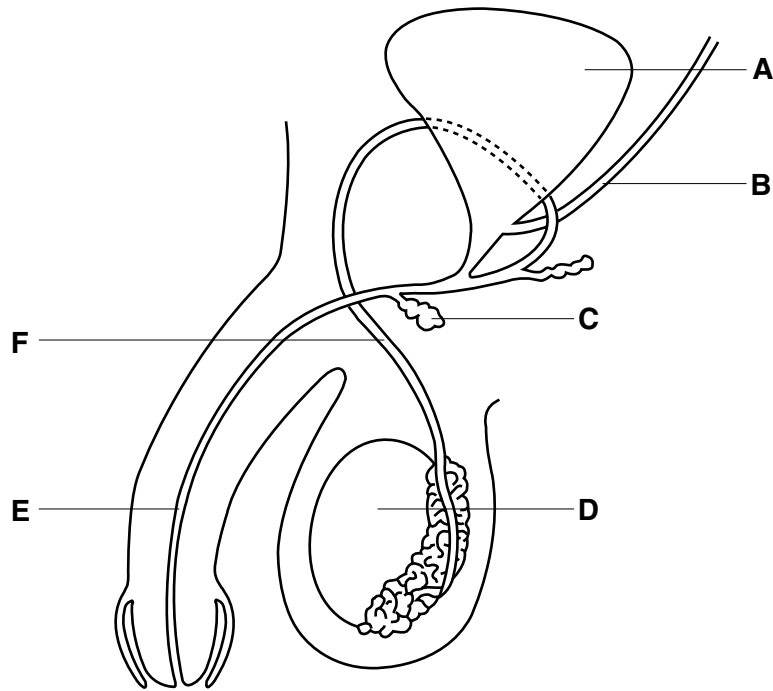

Fig. 7.1

(a) Give the letter of the structure on the diagram that matches each of the following descriptions. You may use each letter once, more than once, or not at all.

where sperms are made ..... [3]

the ureter ..... [3]

the tube that would be cut if the man was sterilised ..... [3]

(b) Complete the sentences about sexual reproduction in humans.

Sperms are deposited close to the cervix, and swim from there to the .....  
 where fertilisation takes place. The new cell that is formed when the sperm fuses with  
 an egg is called a ..... [2]

(c) Gonorrhoea is a disease that is spread by sexual intercourse.  
 Give **two** ways by which the spread of gonorrhoea can be reduced.

1 .....

2 ..... [2]

- 8 Fig. 8.1 shows one of the pyramids in Egypt. The pyramid is 140 m high.

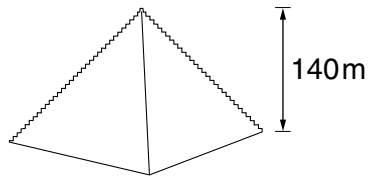

**Fig. 8.1**

A large number of blocks were used to build this pyramid.

Fig. 8.2 shows the final block weighing 100 000 N, that had to be raised to the top of the pyramid.

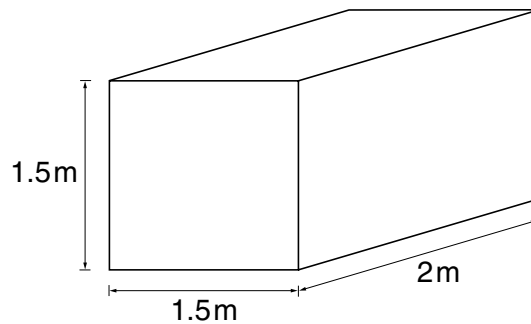

**Fig. 8.2**

- (a) Calculate the mass of this block. (The Earth's gravitational field strength is 10 N/kg)

.....kg [1]

- (b) Calculate the volume of the block

.....m<sup>3</sup> [1]

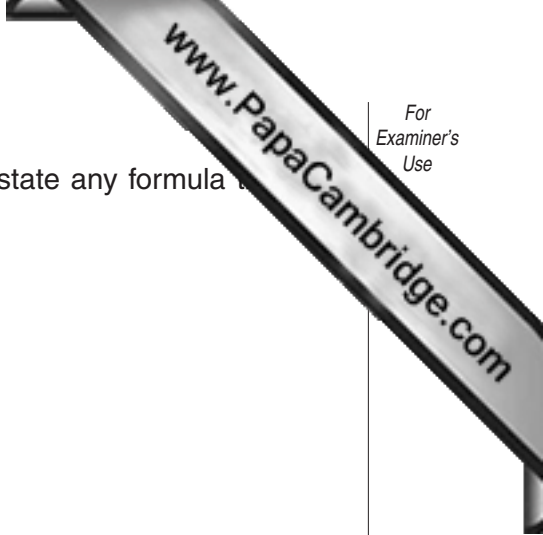

(c) Calculate the density of the block. Show your working and state any formula that you use.

.....kg/m<sup>3</sup> [3]

(d) Calculate the work done in raising this block through 140m to the top of the pyramid. Show your working and state any formula that you use.

.....J [3]

- 9 (a) A student added dilute hydrochloric acid to some substances contained in the test tubes, **A** to **D**, shown in Fig. 9.1.

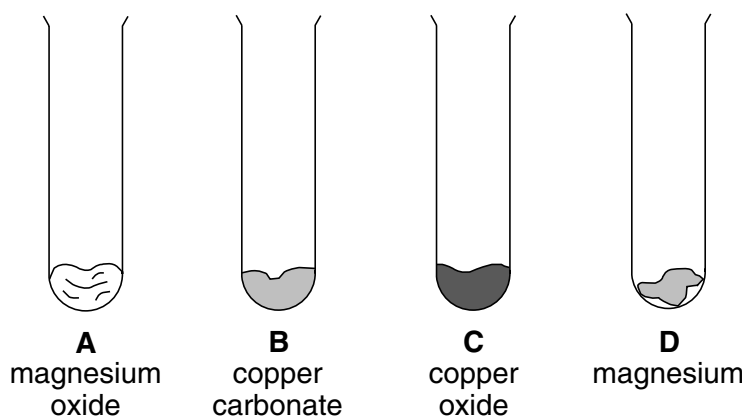

Fig. 9.1

- (i) The results the student recorded are shown in Fig. 9.2. Complete the right hand column in Fig. 9.2 by writing in the letters **A**, **B**, **C** or **D**.

| results recorded during reaction               | appearance of contents of tube when reaction complete | tube |
|--|---|------|
| solid dissolves and carbon dioxide gas evolved | blue solution   |      |
| solid dissolves                                | colourless solution                                   |      |
| solid dissolves                                | blue solution   |      |

[3]

Fig. 9.2

- (ii) Describe the test for carbon dioxide gas.

.....

.....

.....[2]

- (b) (i) What happens to the pH of an acid solution when a base is added to it?

.....[1]

- (ii) Complete the word equation below for the reaction between an acid and a base.

sulphuric acid + nickel oxide → .....[2]







**DATA SHEET**  
**The Periodic Table of the Elements**

|                             |                              | Group  |                              |                              |                               |                               |                             |                               |                            |                             |                             |                            |                              |                               |                            |                           |                             |                            |                               |                              |                              |                              |                             |                             |                              |                          |                             |                              |                          |                             |                              |                            |                              |                             |                            |                               |                               |                               |                            |                               |                                 |                                 |                             |                                 |                              |                                |
|-----------------------------|------------------------------|--|------------------------------|------------------------------|-------------------------------|-------------------------------|-----------------------------|-------------------------------|----------------------------|-----------------------------|-----------------------------|----------------------------|------------------------------|-------------------------------|----------------------------|---------------------------|-----------------------------|----------------------------|-------------------------------|------------------------------|------------------------------|------------------------------|-----------------------------|-----------------------------|------------------------------|--------------------------|-----------------------------|------------------------------|--------------------------|-----------------------------|------------------------------|----------------------------|------------------------------|-----------------------------|----------------------------|-------------------------------|-------------------------------|-------------------------------|----------------------------|-------------------------------|---------------------------------|---------------------------------|-----------------------------|---------------------------------|------------------------------|--------------------------------|
| I                           | II                           | III  | IV                           | V                            | VI                            | VII                           | O                           |                               |                            |                             |                             |                            |                              |                               |                            |                           |                             |                            |                               |                              |                              |                              |                             |                             |                              |                          |                             |                              |                          |                             |                              |                            |                              |                             |                            |                               |                               |                               |                            |                               |                                 |                                 |                             |                                 |                              |                                |
| 7<br><b>Li</b><br>Lithium   | 9<br><b>Be</b><br>Beryllium  | <table border="1" style="width: 100%; border-collapse: collapse; text-align: center;"> <tr> <td>1<br/><b>H</b><br/>Hydrogen</td> <td>11<br/><b>B</b><br/>Boron</td> <td>12<br/><b>C</b><br/>Carbon</td> <td>14<br/><b>N</b><br/>Nitrogen</td> <td>16<br/><b>O</b><br/>Oxygen</td> <td>19<br/><b>F</b><br/>Fluorine</td> <td>20<br/><b>Ne</b><br/>Neon</td> </tr> <tr> <td>2<br/><b>He</b><br/>Helium</td> <td>13<br/><b>Al</b><br/>Aluminium</td> <td>14<br/><b>Si</b><br/>Silicon</td> <td>15<br/><b>P</b><br/>Phosphorus</td> <td>16<br/><b>S</b><br/>Sulphur</td> <td>17<br/><b>Cl</b><br/>Chlorine</td> <td>18<br/><b>Ar</b><br/>Argon</td> </tr> </table> |                              |                              |                               |                               |                             |                               |                            |                             |                             | 1<br><b>H</b><br>Hydrogen  | 11<br><b>B</b><br>Boron      | 12<br><b>C</b><br>Carbon      | 14<br><b>N</b><br>Nitrogen | 16<br><b>O</b><br>Oxygen  | 19<br><b>F</b><br>Fluorine  | 20<br><b>Ne</b><br>Neon    | 2<br><b>He</b><br>Helium      | 13<br><b>Al</b><br>Aluminium | 14<br><b>Si</b><br>Silicon   | 15<br><b>P</b><br>Phosphorus | 16<br><b>S</b><br>Sulphur   | 17<br><b>Cl</b><br>Chlorine | 18<br><b>Ar</b><br>Argon     | 4<br><b>He</b><br>Helium |                             |                              |                          |                             |                              |                            |                              |                             |                            |                               |                               |                               |                            |                               |                                 |                                 |                             |                                 |                              |                                |
| 1<br><b>H</b><br>Hydrogen   | 11<br><b>B</b><br>Boron      |  |                              |                              |                               |                               |                             |                               |                            |                             |                             | 12<br><b>C</b><br>Carbon   | 14<br><b>N</b><br>Nitrogen   | 16<br><b>O</b><br>Oxygen      | 19<br><b>F</b><br>Fluorine | 20<br><b>Ne</b><br>Neon   |                             |                            |                               |                              |                              |                              |                             |                             |                              |                          |                             |                              |                          |                             |                              |                            |                              |                             |                            |                               |                               |                               |                            |                               |                                 |                                 |                             |                                 |                              |                                |
| 2<br><b>He</b><br>Helium    | 13<br><b>Al</b><br>Aluminium | 14<br><b>Si</b><br>Silicon   | 15<br><b>P</b><br>Phosphorus | 16<br><b>S</b><br>Sulphur    | 17<br><b>Cl</b><br>Chlorine   | 18<br><b>Ar</b><br>Argon      |                             |                               |                            |                             |                             |                            |                              |                               |                            |                           |                             |                            |                               |                              |                              |                              |                             |                             |                              |                          |                             |                              |                          |                             |                              |                            |                              |                             |                            |                               |                               |                               |                            |                               |                                 |                                 |                             |                                 |                              |                                |
| 23<br><b>Na</b><br>Sodium   | 24<br><b>Mg</b><br>Magnesium | 27<br><b>Al</b><br>Aluminium   | 28<br><b>Si</b><br>Silicon   | 31<br><b>P</b><br>Phosphorus | 32<br><b>S</b><br>Sulphur     | 35.5<br><b>Cl</b><br>Chlorine | 40<br><b>Ar</b><br>Argon    | 39<br><b>K</b><br>Potassium   | 40<br><b>Ca</b><br>Calcium | 45<br><b>Sc</b><br>Scandium | 48<br><b>Ti</b><br>Titanium | 51<br><b>V</b><br>Vanadium | 52<br><b>Cr</b><br>Chromium  | 55<br><b>Mn</b><br>Manganese  | 56<br><b>Fe</b><br>Iron    | 59<br><b>Co</b><br>Cobalt | 59<br><b>Ni</b><br>Nickel   | 64<br><b>Cu</b><br>Copper  | 65<br><b>Zn</b><br>Zinc       | 70<br><b>Ga</b><br>Gallium   | 73<br><b>Ge</b><br>Germanium | 75<br><b>As</b><br>Arsenic   | 79<br><b>Se</b><br>Selenium | 80<br><b>Br</b><br>Bromine  | 84<br><b>Kr</b><br>Krypton   |                          |                             |                              |                          |                             |                              |                            |                              |                             |                            |                               |                               |                               |                            |                               |                                 |                                 |                             |                                 |                              |                                |
| 85<br><b>Rb</b><br>Rubidium | 88<br><b>Sr</b><br>Strontium | 89<br><b>Y</b><br>Yttrium  | 91<br><b>Zr</b><br>Zirconium | 93<br><b>Nb</b><br>Niobium   | 96<br><b>Mo</b><br>Molybdenum | 101<br><b>Ru</b><br>Ruthenium | 103<br><b>Rh</b><br>Rhodium | 106<br><b>Pd</b><br>Palladium | 108<br><b>Ag</b><br>Silver | 112<br><b>Cd</b><br>Cadmium | 115<br><b>In</b><br>Indium  | 119<br><b>Sn</b><br>Tin    | 122<br><b>Sb</b><br>Antimony | 128<br><b>Te</b><br>Tellurium | 127<br><b>I</b><br>Iodine  | 131<br><b>Xe</b><br>Xenon | 133<br><b>Cs</b><br>Caesium | 137<br><b>Ba</b><br>Barium | 139<br><b>La</b><br>Lanthanum | 178<br><b>Hf</b><br>Hafnium  | 181<br><b>Ta</b><br>Tantalum | 184<br><b>W</b><br>Tungsten  | 190<br><b>Os</b><br>Osmium  | 192<br><b>Ir</b><br>Iridium | 195<br><b>Pt</b><br>Platinum | 197<br><b>Au</b><br>Gold | 201<br><b>Hg</b><br>Mercury | 204<br><b>Tl</b><br>Thallium | 207<br><b>Pb</b><br>Lead | 209<br><b>Bi</b><br>Bismuth | 210<br><b>Po</b><br>Polonium | 226<br><b>Ra</b><br>Radium | 227<br><b>Ac</b><br>Actinium | 232<br><b>Th</b><br>Thorium | 238<br><b>U</b><br>Uranium | 238<br><b>Np</b><br>Neptunium | 238<br><b>Pu</b><br>Plutonium | 238<br><b>Am</b><br>Americium | 238<br><b>Cm</b><br>Curium | 238<br><b>Bk</b><br>Berkelium | 238<br><b>Cf</b><br>Californium | 238<br><b>Es</b><br>Einsteinium | 238<br><b>Fm</b><br>Fermium | 238<br><b>Md</b><br>Mendelevium | 238<br><b>No</b><br>Nobelium | 238<br><b>Lr</b><br>Lawrencium |

|                            |                                  |                               |                              |                              |                                |                              |                                |                                |                             |                                 |                               |                                |
|----------------------------|----------------------------------|-------------------------------|------------------------------|------------------------------|--------------------------------|------------------------------|--------------------------------|--------------------------------|-----------------------------|---------------------------------|-------------------------------|--------------------------------|
| 140<br><b>Ce</b><br>Cerium | 141<br><b>Pr</b><br>Praseodymium | 144<br><b>Nd</b><br>Neodymium | 150<br><b>Sm</b><br>Samarium | 152<br><b>Eu</b><br>Europium | 157<br><b>Gd</b><br>Gadolinium | 159<br><b>Tb</b><br>Terbium  | 162<br><b>Dy</b><br>Dysprosium | 165<br><b>Ho</b><br>Holmium    | 167<br><b>Er</b><br>Erbium  | 169<br><b>Tm</b><br>Thulium     | 173<br><b>Yb</b><br>Ytterbium | 175<br><b>Lu</b><br>Lutetium   |
| 58                         | 59                               | 60                            | 62                           | 63                           | 64                             | 65                           | 66                             | 67                             | 68                          | 69                              | 70                            | 71                             |
| 90<br><b>Th</b><br>Thorium | 91<br><b>Pa</b><br>Protactinium  | 92<br><b>U</b><br>Uranium     | 94<br><b>Pu</b><br>Plutonium | 95<br><b>Am</b><br>Americium | 96<br><b>Cm</b><br>Curium      | 97<br><b>Bk</b><br>Berkelium | 98<br><b>Cf</b><br>Californium | 99<br><b>Es</b><br>Einsteinium | 100<br><b>Fm</b><br>Fermium | 101<br><b>Md</b><br>Mendelevium | 102<br><b>No</b><br>Nobelium  | 103<br><b>Lr</b><br>Lawrencium |

3-71 Lanthanoid series  
0-103 Actinoid series

a = relative atomic mass  
X = atomic symbol  
b = proton (atomic) number

The volume of one mole of any gas is 24 dm<sup>3</sup> at room temperature and pressure (r.t.p.).