

| |
|--|
| |
|--|

Candidate Name _____

**International General Certificate of Secondary Education
CAMBRIDGE INTERNATIONAL EXAMINATIONS**

**COMBINED SCIENCE
CO-ORDINATED SCIENCES**

PAPER 6 Alternative to Practical

**0653/6
0654/6**

OCTOBER/NOVEMBER SESSION 2002

1 hour

Candidates answer on the question paper.
No additional materials are required.

TIME 1 hour

INSTRUCTIONS TO CANDIDATES

Write your name, Centre number and candidate number in the spaces at the top of this page.

Answer **all** questions.

Write your answers in the spaces provided on the question paper.

INFORMATION FOR CANDIDATES

The number of marks is given in brackets [] at the end of each question or part question.

| FOR EXAMINER'S USE | |
|--------------------|--|
| 1 | |
| 2 | |
| 3 | |
| 4 | |
| 5 | |
| 6 | |
| TOTAL | |

- 1 When aqueous sodium thiosulphate reacts with acid, a precipitate of sulphur is formed. An experiment was done to investigate how the time taken for this reaction varied with temperature.
- 50 cm³ of aqueous sodium thiosulphate, was placed in a conical flask.
 - The conical flask was warmed to a temperature of 30 °C.
 - 5 cm³ of hydrochloric acid was added to the conical flask and a clock was started.
 - The flask was placed on top of a black cross drawn on white paper, as shown in Fig. 1.1.
 - The time taken for enough precipitate to form, so that the cross could not be seen, was noted in Fig. 1.2.

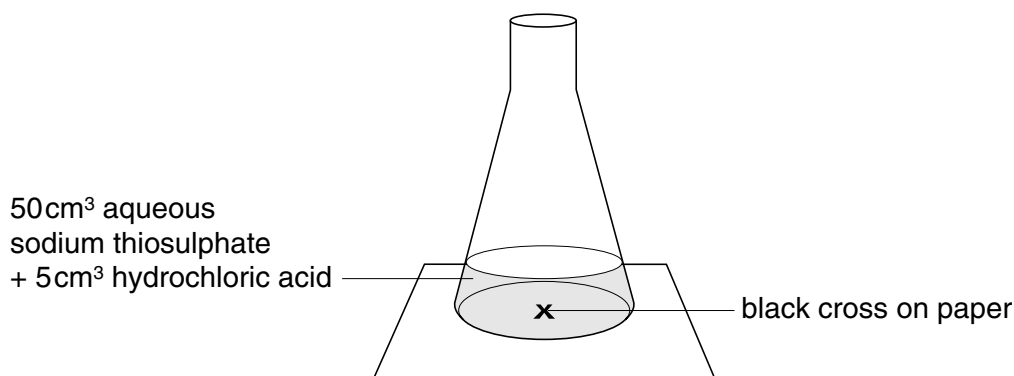

Fig. 1.1

| | | | | | |
|-------------------------------------|----|----|----|----|----|
| temperature/°C | 30 | 40 | 50 | 60 | 70 |
| time taken for cross to disappear/s | 75 | | | | |

Fig. 1.2

The procedure was repeated at four different temperatures. The times taken for the precipitates to form are shown in Fig. 1.3.

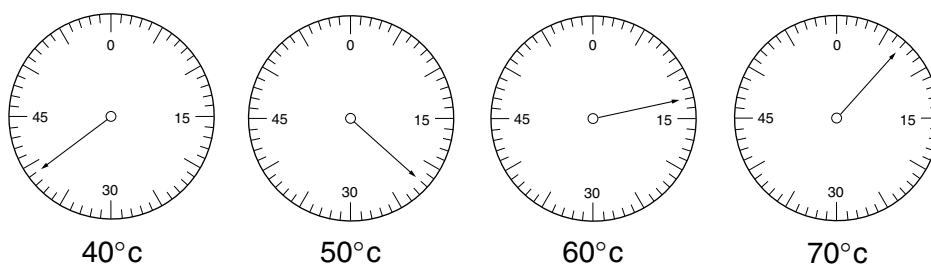
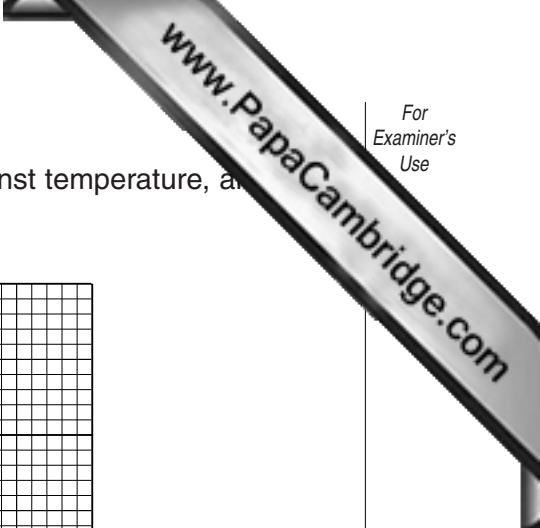

Fig. 1.3

- (a) Read the clock dials in Fig. 1.3 and record the times in Fig. 1.2.

[2]



- (b) On the grid provided, plot a graph of time (vertical axis) against temperature, and draw a smooth curve through the points.

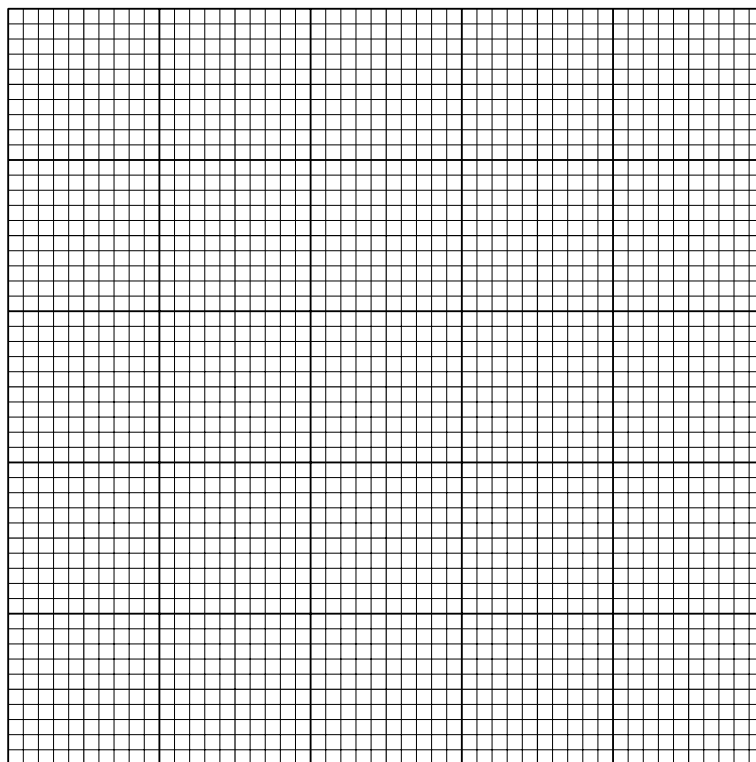

[4]

- (c) Describe the relationship between the temperature and the time taken for the reaction to occur.

.....
[1]

- (d) Use your graph to find the temperature required to give a reaction time of 50 seconds. Show how you do this on the graph.

temperature =°C [1]

- (e) The graph you have plotted does not show the relationship between the **rate** of reaction and the temperature. Briefly explain what you would do with the results to show such a relationship.

.....
[1]

- (f) Briefly describe how you would carry out an experiment at 0 °C to find the reaction time.

.....
[1]

- 2 A student did the following experiment to investigate the effect of two different solutions on potato cells.

Using a potato she carefully prepared four chips of size 8.0 x 0.5 x 0.5 cm.

She put each chip into a separate test-tube.

She then added solution **A** to two of the tubes. She added enough to cover the chips.

She added solution **B** to the other two test-tubes, as shown in Fig. 2.1.

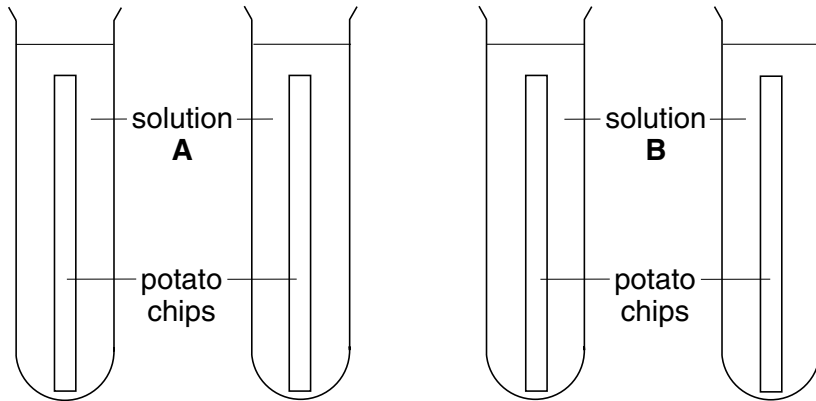

Fig. 2.1

She left the four tubes for 30 minutes.

After this time she removed the chips from the solutions, and measured their lengths.

One chip from **A** and one from **B** have already been measured.

- (a) (i) Using a ruler measure the lengths of the two other chips. Record the values in Fig. 2.3.

chip from solution **A**

chip from solution **B**

Fig. 2.2

| length of chip from solution A /cm | length of chip from solution B /cm |
|---|---|
| 7.7 | |
| | 8.2 |

Fig. 2.3

[2]

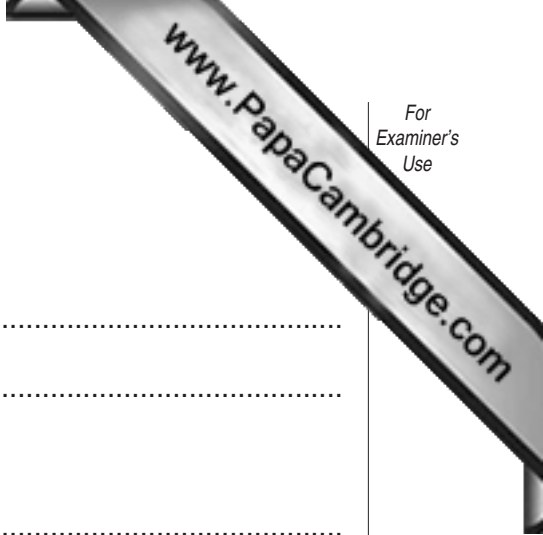

(ii) Calculate the average length of the pairs of chips
from solution **A**,

.....
.....

from solution **B**.

.....
.....[2]

(iii) All the chips were 8.0 cm long at first. Use the average value to calculate the
percentage change in length of chips from solution **A**.

.....
.....
.....[2]

Water can move into or out of the chips depending on the concentration of the
solutions **A** or **B**.

(b) (i) From the results suggest why the length of the chips in solution **A** has changed.

.....
.....[1]

(ii) From the results suggest why the length of the chips in solution **B** has changed.

.....
.....[1]

(c) A potato chip was put into a new solution, **C**. After 30 minutes there was no change in
the length of the potato chip. Suggest a reason why there was no change.

.....
.....
.....[2]

- 3 The teacher demonstrated the use of a Geiger-Muller tube, connected to a scaler, to investigate a radioactive sample. The apparatus is shown in Fig. 3.1.

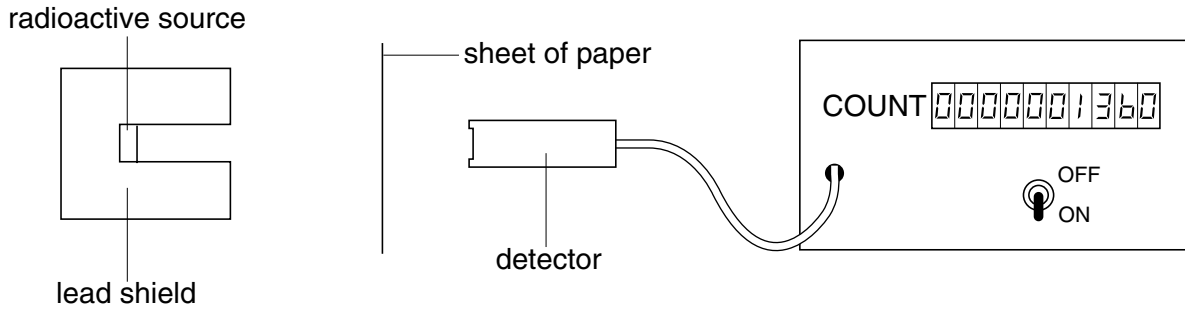

Fig. 3.1

In each experiment, the radioactivity was counted for five minutes or for ten minutes. Fig. 3.2, shows how the count rate was changed when sheets of paper, aluminium and lead were placed in front of the detector and when the radioactive source was removed.

| expt. no | how the count was done | total count | time of count/minutes | counts per minute |
|----------|--|-------------|-----------------------|-------------------|
| 1 | nothing was placed between the source and the detector | 3875 | 5 | |
| 2 | a sheet of paper was placed between the source and the detector | 1760 | 5 | |
| 3 | a 1 mm sheet of aluminium was placed between the source and the detector | 640 | 5 | |
| 4 | a 3 mm thick sheet of aluminium was placed between the source and the detector | 335 | 5 | |
| 5 | a 3 mm sheet of lead was placed between the source and the detector | 170 | 10 | |
| 6 | the source was taken away from the apparatus | 90 | 10 | |

Fig. 3.2

- (a) Complete the final column of the table by calculating the counts per minute. [2]
- (b) Explain the reason for experiment 6.

.....

.....[1]

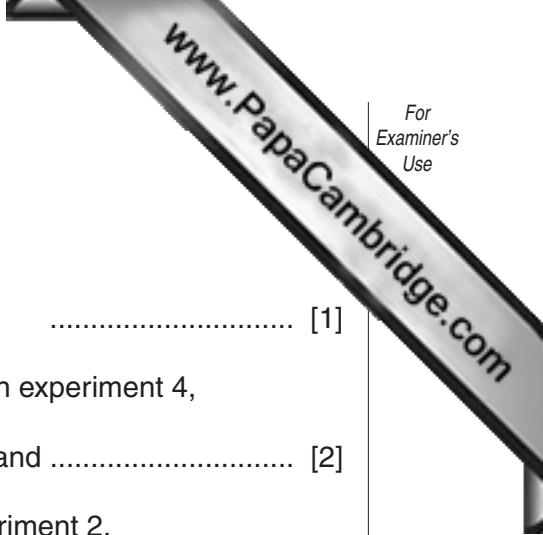

(c) Use the data in the table to suggest

(i) what type of radiation was detected in experiment 5,
..... [1]

(ii) what types of radiation were stopped by the aluminium in experiment 4,
..... and [2]

(iii) what type of radiation was stopped by the paper in experiment 2.
..... [1]

(d) State one rule for the safety of the teacher and the class when a radioactive source is being used in an experiment.
.....[1]

(e) State how the radioactive source should be stored when it is not in use.
.....
.....[2]

- 4 A student did an experiment to compare the carbon dioxide content of inspired (breathed in) air with that of expired (breathed out) air. He used the apparatus in Fig. 4.1

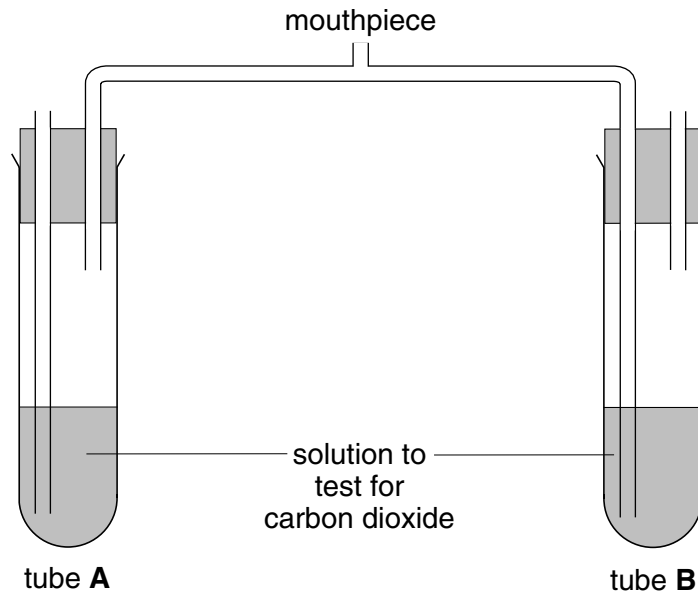

Fig. 4.1

The tubes were arranged so that inspired air bubbled through one tube, and expired air bubbled through the other tube. The student breathed in and out through the mouthpiece.

- (a) (i) Which tube, **A** or **B**, has inspired air passing through, and which has expired air passing through?

inspired air

expired air[1]

- (ii) Name a solution that can be used as a test for carbon dioxide.

.....

What is the result of this test?

.....[2]

The student breathed in and out through the apparatus and used a stop watch to time how long it took for one of the tubes to show a reaction.

- (iii) Which tube would you expect to show a reaction first?

.....

Explain your answer.

.....

.....[2]

The student did the experiment twice, once before, and once after exercise. The times for a reaction are shown by the stop watches in Fig. 4.2.

(b) (i) Write the readings of the stop watches in the spaces below Fig. 4.2.

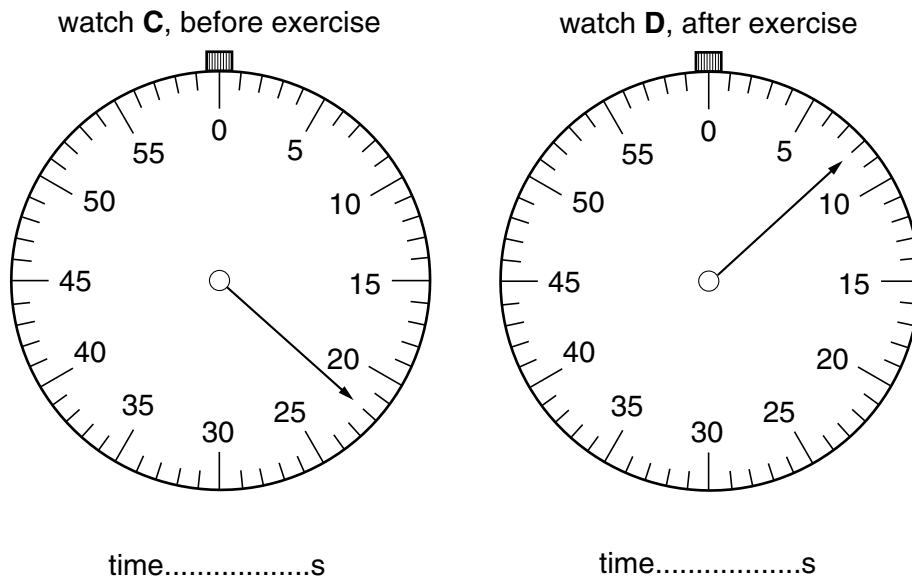

Fig. 4.2

[2]

(ii) Explain why the two reaction times are different.

.....

.....

.....[2]

(c) How would the amounts of oxygen differ between inspired air and expired air?

.....

.....[1]

- 5 A student did an experiment to find the energy change when a weighed mass of solid **Z** was dissolved in a measured volume of water in a glass beaker. The energy change during the reaction was shown by the change in temperature of the solution in the beaker and the water.

Fig. 5.1 shows the balance reading when the beaker was weighed.

Fig. 5.2 shows the balance reading when the beaker containing solid **Z** was weighed.

Fig. 5.3 shows the temperature of the 25 cm³ of water.

Fig. 5.4 shows the temperature of the water after solid **Z** had dissolved.

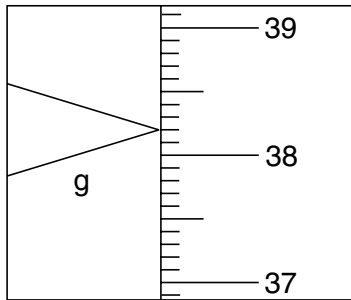

Fig. 5.1

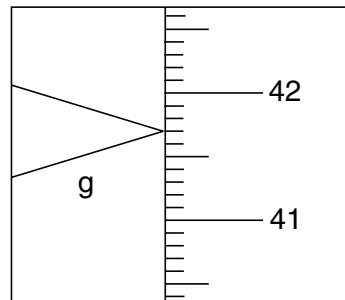

Fig. 5.2

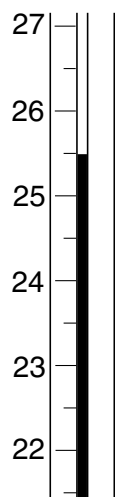

Fig. 5.3

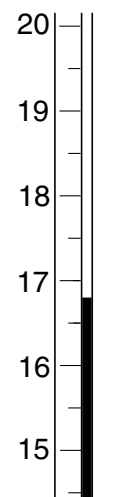

Fig. 5.4

- (a) Read the balance and the thermometer scales and then complete Fig. 5.5.

| | |
|--|----------------------------|
| mass of beaker | $M_1 = \dots\dots\dots$ g |
| mass of beaker + solid Z | $M_2 = \dots\dots\dots$ g |
| mass of solid Z | $M_3 = \dots\dots\dots$ g |
| temperature of the 25 cm ³ of water | $T_1 = \dots\dots\dots$ °C |
| temperature of the solution of Z in water | $T_2 = \dots\dots\dots$ °C |

Fig. 5.5

- (b) Calculate the temperature change, $T_2 - T_1$.

temperature change, $T_2 - T_1 = \dots\dots\dots^\circ\text{C}$ [1]

- (c) (i) Convert M_1 , the mass of the beaker in grams, into kilograms.

mass of the beaker in kilograms = $\dots\dots\dots$ kg [1]

- (ii) Multiply this mass by 670. This gives the heat energy stored by the beaker, H Joules, for each degree Celsius change.

heat energy stored by the beaker, $H = \dots\dots\dots$ Joules [1]

- (d) Using your answers to (b) and (c) (ii), calculate the total heat energy change when solid Z dissolved in water, using the formula below.

total heat energy change = $(T_2 - T_1) \times (H + 105)$ Joules

total heat energy change = $\dots\dots\dots$ Joules [1]

- (e) Is the dissolving of Z in water exothermic or endothermic? Explain your answer.

.....
.....[1]

- 6 Lemon juice contains citric acid which gives it a sour taste. Citric acid reacts with sodium hydroxide to form the salt sodium citrate. Study the information given in Fig. 6.1 and Fig. 6.2. Use the information to answer the questions which follow.

| name of substance | appearance | solubility in water |
|-------------------|----------------|---------------------|
| citric acid | white crystals | soluble |
| sodium citrate | white crystals | soluble |

Fig. 6.1

| name of indicator | colour at pH5 | colour at pH9 |
|-------------------|---------------|---------------|
| phenolphthalein | colourless | purple |

Fig. 6.2

- (a) Describe how you could make a sample of citric acid crystals from the juice of a lemon.

.....
.....
.....
.....[3]

- (b) Describe how you could make a sample of sodium citrate crystals using the citric acid crystals from the experiment in (a) and the indicator named in Fig. 6.2. You may assume that sodium hydroxide solution and the usual laboratory apparatus are available.

.....
.....
.....
.....
.....
.....
.....
.....
.....
.....
.....
.....
.....
.....
.....
.....[7]