



UNIVERSITY OF CAMBRIDGE INTERNATIONAL EXAMINATIONS
International General Certificate of Secondary Education

CANDIDATE
NAME

CENTRE
NUMBER

--	--	--	--	--

CANDIDATE
NUMBER

--	--	--	--

* 5 9 2 4 6 8 3 8 8 0 *

COMBINED SCIENCE

0653/33

Paper 3 (Extended)

October/November 2010

1 hour 15 minutes

Candidates answer on the Question Paper.

No Additional Materials are required.

READ THESE INSTRUCTIONS FIRST

Write your Centre number, candidate number and name on all the work you hand in.

Write in dark blue or black pen.

You may use a soft pencil for any diagrams, graphs, tables or rough working.

Do not use staples, paper clips, highlighters, glue or correction fluid.

DO NOT WRITE IN ANY BARCODES.

Answer **all** questions.

A copy of the Periodic Table is printed on page 20.

At the end of the examination, fasten all your work securely together.

The number of marks is given in brackets [] at the end of each question or part question.

For Examiner's Use	
1	
2	
3	
4	
5	
6	
7	
8	
9	
Total	

This document consists of **20** printed pages.



1 Fig. 1.1 shows some stages in the formation of a human fetus.

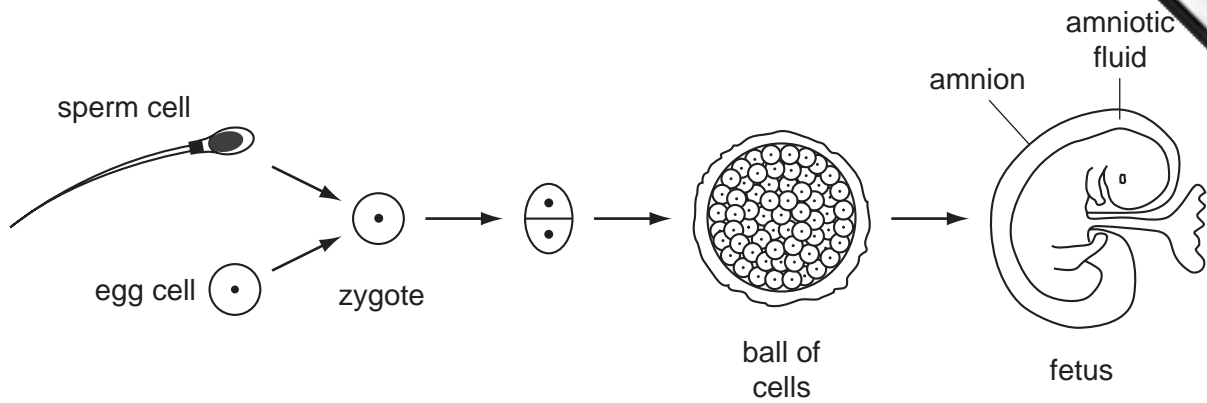

Fig. 1.1

(a) Most human cells contain 46 chromosomes, but egg cells and sperm cells contain only 23 chromosomes each.

Suggest a reason for this.

.....
 [1]

(b) Name the part of the reproductive system in which each of these events takes place.

(i) Eggs are produced. [1]

(ii) Fertilisation takes place. [1]

(c) Describe the function of the amnion.

.....

 [2]

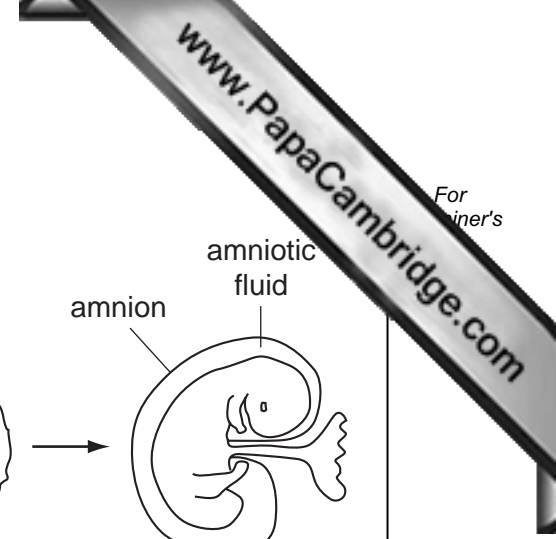

For
 iner's

(d) A disease called thalassaemia is caused by a person's genes.

The haemoglobin gene has two alleles, **T** and **t**. A person with the alleles **tt** has thalassaemia, but a person with alleles **Tt** does not.

(i) State which allele, **T** or **t**, is dominant. Explain your answer.

allele

explanation

..... [1]

(ii) Complete the genetic diagram to show how two parents who do not have thalassaemia could have a child with thalassaemia.

phenotypes of parents

man without thalassaemia

woman without thalassaemia

genotypes of parents

Tt

.....

gametes

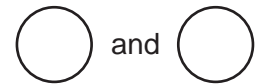
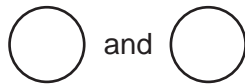

gametes from woman



gametes from man



[4]

(iii) Thalassaemia reduces the amount of normal haemoglobin in a person's blood.

Explain why someone with thalassaemia often does not have the energy to do vigorous exercise.

.....

 [2]

- 2 (a) Fig. 2.1 shows apparatus used in the electrolysis of copper chloride solution.

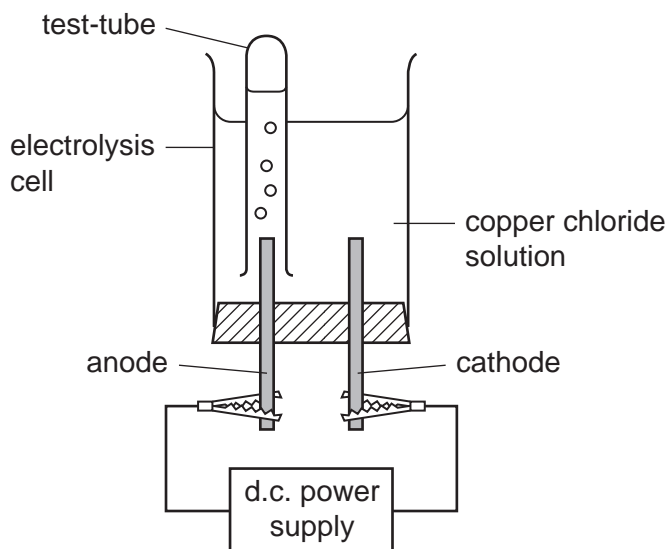

Fig. 2.1

- (i) Describe what is observed at the cathode.

..... [1]

- (ii) Chloride ions have a single negative electrical charge, Cl^- .

For every copper ion in the solution, two chloride ions are present.

Deduce the electrical charge of a copper ion.

Show how you obtained your answer.

..... [2]

- (iii) Fig. 2.2 shows diagrams of two particles, **L** and **M**. Each of these particles has 17 protons in their nucleus.

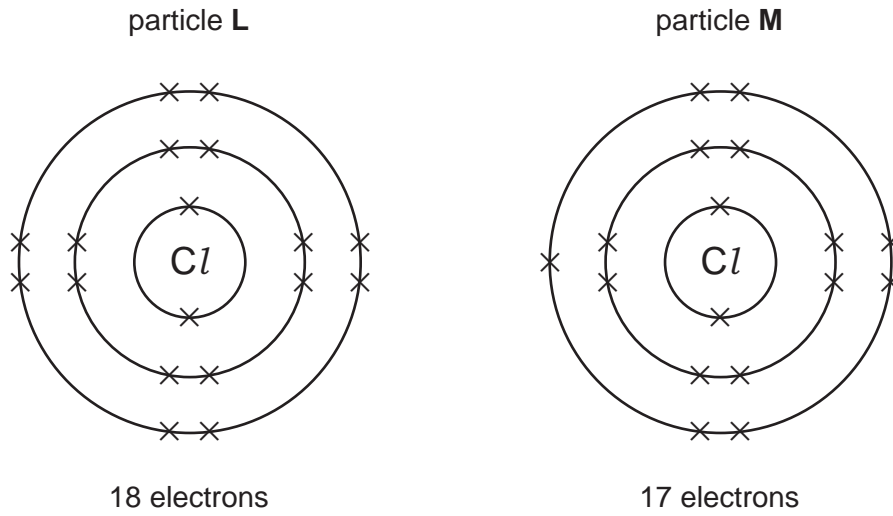

Fig. 2.2

State and explain which one of these particles, **L** or **M**, moves towards the anode during electrolysis.

particle

explanation

.....

..... [2]

- (iv) The bubbles of gas which rise from the anode contain diatomic molecules of chlorine.

Complete the bonding diagram below to show how the outer electrons are arranged in a chlorine molecule.

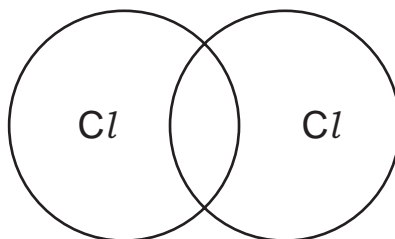

[2]

- (b) The apparatus shown in Fig. 2.3 can be used to react lead oxide, PbO , and carbon. For
inert's

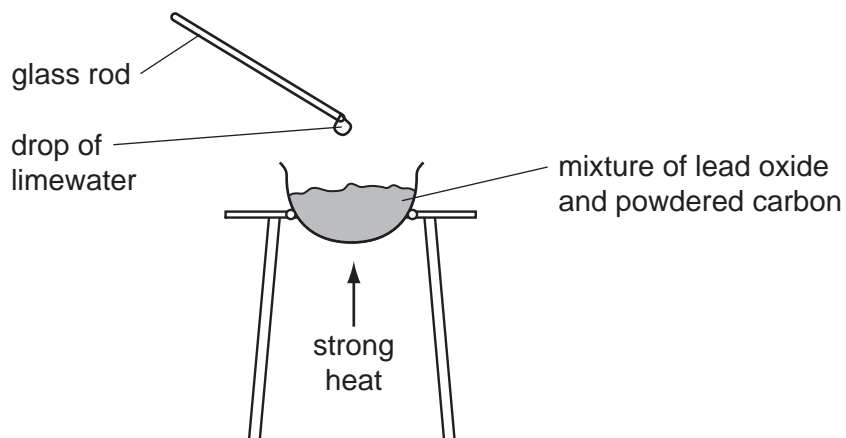

Fig. 2.3

When the mixture is heated, a redox reaction occurs in which lead oxide is reduced.

The drop of limewater suspended on the glass rod turns cloudy.

- (i) Name the gas which is produced in this redox reaction.

..... [1]

- (ii) Suggest the balanced symbolic equation for the redox reaction between lead oxide and carbon.

..... [2]

- 3 (a) (i) Complete Table 3.1 to show the properties of alpha, beta and gamma radiation.

Table 3.1

	description	charge	range in air	ionising ability
alpha		positive	5 cm	very strong
beta	electron		50 cm	
gamma	electromagnetic wave		many kilometres	weak

[4]

- (ii) Many people have smoke detectors in their houses.

Smoke detectors contain a radioactive source which emits alpha radiation.

Explain why the alpha radiation from the smoke detector is not dangerous to people living in the house.

.....

 [1]

- (b) A scientist uses a Geiger counter to measure the radiation from a radioactive source. She records the results every hour.

Fig. 3.1 shows the graph of her results.

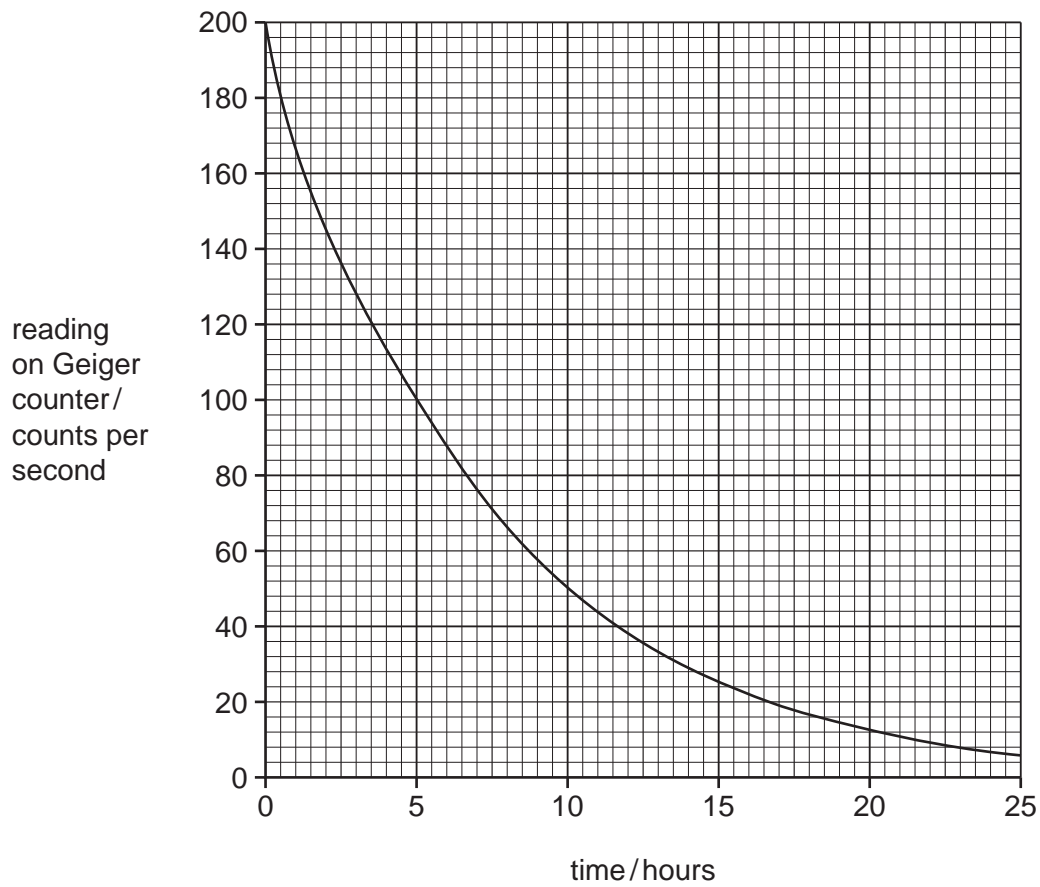

Fig. 3.1

Calculate the half-life of the radioactive source.

Show your working.

..... [2]

4 Soya beans are an important crop in many tropical and subtropical countries, because they contain a lot of protein.

(a) A farmer grows soya beans in a field on a steep slope.

Describe **two** things the farmer could do to reduce the risk of soil erosion.

1

.....

2

..... [2]

(b) Soya beans and other crops are often attacked by aphids and other insect pests.

Farmers may use pesticides or biological control to kill the pests.

(i) Describe **one** advantage and **one** disadvantage of using pesticides, rather than biological control, to control pests of crops.

advantage

.....

disadvantage

..... [2]

(ii) State what is meant by a *systemic pesticide* and explain **one** advantage of using a systemic pesticide rather than a contact pesticide.

meaning

.....

advantage

..... [2]

5 (a) Fig. 5.1 shows a circuit built by a student.

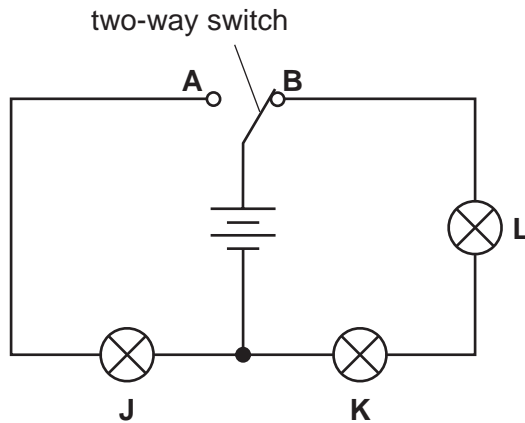

Fig. 5.1

(i) The switch is at position **B**. Which lamps will be lit? [1]

(ii) The switch is then moved to position **A**.

What happens to lamps **J**, **K** and **L**?

lamp **J**

lamp **K**

lamp **L**

[2]

(b) The student has six resistors as shown in Fig. 5.2.

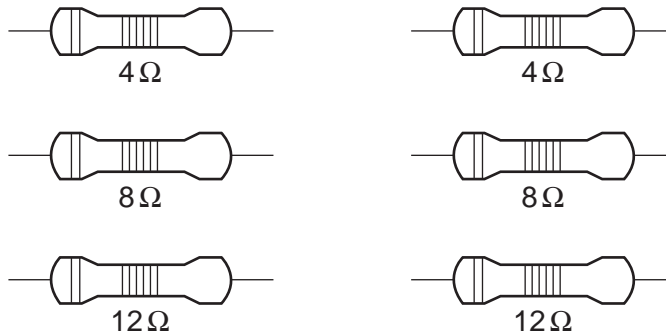

Fig. 5.2

Explain how he can combine **two** of these resistors to get a total resistance of 6 ohms.

.....

[3]

(c) Fig. 5.3 shows a simple electrical generator.

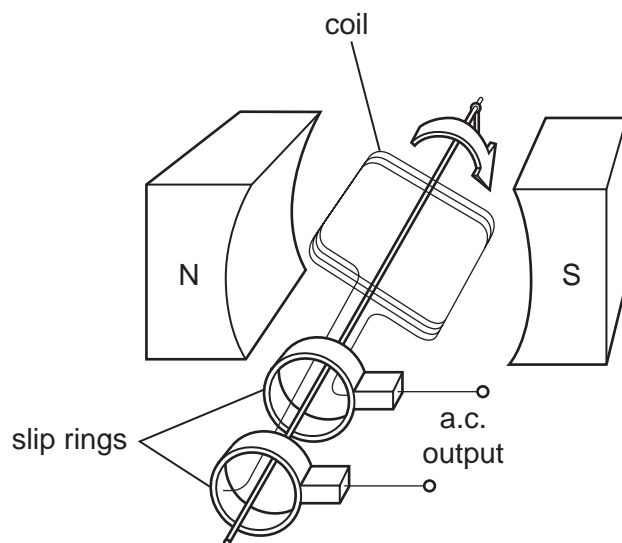

Fig. 5.3

(i) Explain why a voltage is induced in the coil when the coil is turned.

.....
..... [1]

(ii) Explain why this generator produces an alternating current.

.....
..... [1]

- 6 A solution of sodium chloride is produced when sodium hydroxide solution, an alkali, is neutralised by dilute hydrochloric acid. Fig. 6.1 shows apparatus which can be used to carry out this neutralisation.

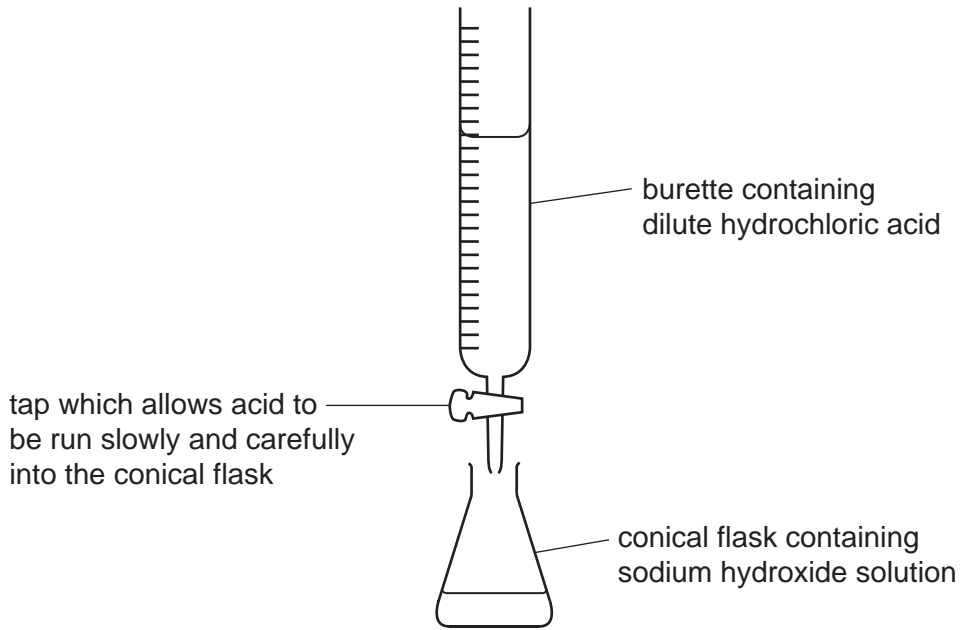

Fig. 6.1

- (a) Complete the balanced symbolic equation, involving ions and molecules, for the neutralisation reaction between an aqueous acid and an aqueous alkali.



- (b) A student adds a few drops of litmus solution, an indicator, to the sodium hydroxide solution.

Suggest what the student should then do in order to produce a **neutral** solution of sodium chloride, using only the apparatus shown in Fig. 6.1.

.....

 [2]

- (c) Suggest how the student could use information gained from the experiment in (b) to obtain a sample of dry, **colourless** sodium chloride crystals which do not contain any litmus.

.....

 [3]

7 (a) Polar bears live in the cold, arctic region. They have thick, white fur.

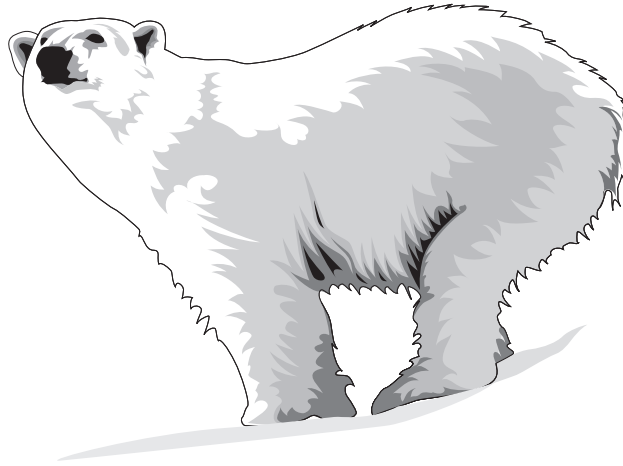

(i) Describe how fur keeps a polar bear warm.

.....
.....
..... [2]

(ii) Explain why white fur will keep a polar bear warmer than black fur.

.....
.....
..... [2]

(b) An elephant can communicate with other elephants using infra-sound. This is low frequency vibration, which is usually impossible for a human to hear.

(i) Suggest a possible frequency for this vibration and explain how you chose your answer.

frequency Hz

explanation

..... [1]

(ii) State the meaning of the term *frequency*.

.....

..... [1]

(iii) Fig. 7.1 shows an oscilloscope trace for a low frequency sound which the human ear can just hear.

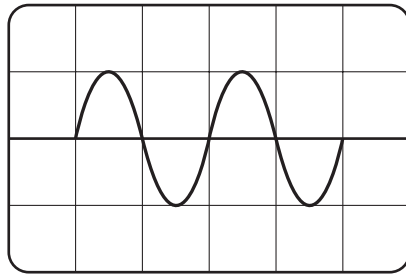

Fig. 7.1

On Fig. 7.2 draw the trace of an infra-sound wave of the same amplitude.

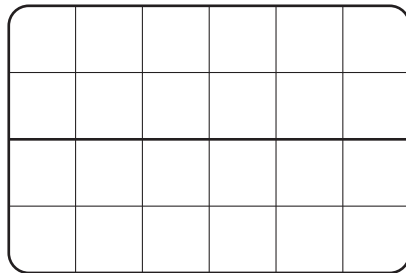

Fig. 7.2

[2]

(c) Fig. 7.3 shows a magnifying glass being used to look at a caterpillar.

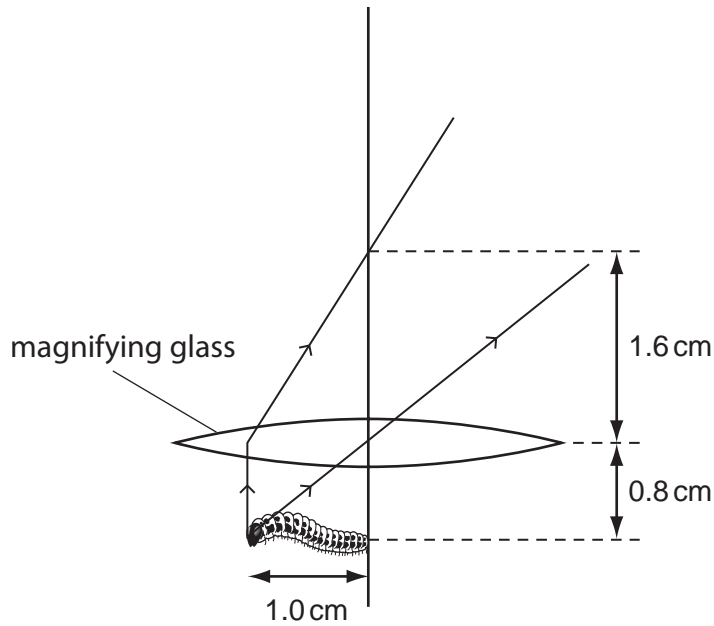

Fig. 7.3

- (i) State the focal length of the lens. [1]
- (ii) Complete the ray diagram to show how the eye sees an enlarged image of the caterpillar. [2]
- (iii) This image is called a virtual image.

Explain the meaning of the term *virtual image*.

.....
 [1]

8 Carbon and hydrogen combine to form hydrocarbons.

Ethene, C_2H_4 , is a gaseous, unsaturated hydrocarbon, which is of industrial importance.

(a) Complete the displayed formula of the ethene molecule which has been started below.



[2]

(b) Unsaturated hydrocarbons are made in industry from fractions obtained by the fractional distillation of oil (petroleum).

Name the process which is used to make unsaturated hydrocarbons, and describe briefly how it is done.

name of process

description

.....

.....

..... [3]

(c) Describe, in terms of changes to chemical bonds, what happens when ethene molecules react to form molecules of poly(ethene).

.....

.....

..... [2]

(d) Calculate the relative formula mass of ethene.

Show your working.

..... [2]

- 9 A healthy plant growing in a pot was watered and placed in a sunny window. A transparent plastic bag was placed over the plant, as shown in Fig. 9.1.

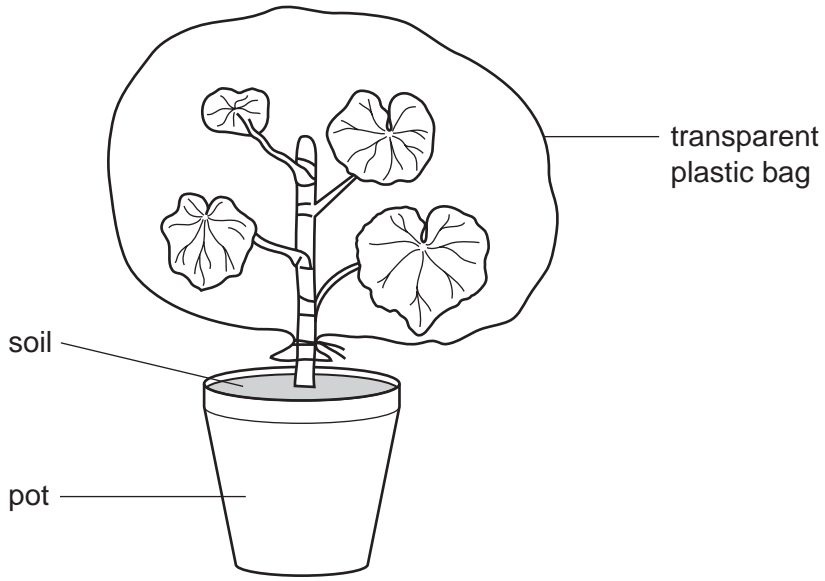

Fig. 9.1

- (a) The temperature near the window fell overnight. The next morning, small droplets of water were visible on the inside of the plastic bag.

Explain why the droplets of water appeared on the inside of the plastic bag.

.....

.....

.....

.....

.....

[4]

- (b) The plastic bag was then removed from the plant. The next day was warm and and by the end of the day the plant had lost so much water that it wilted.

Fig. 9.2 shows a cell from a leaf before and after the plant wilted.

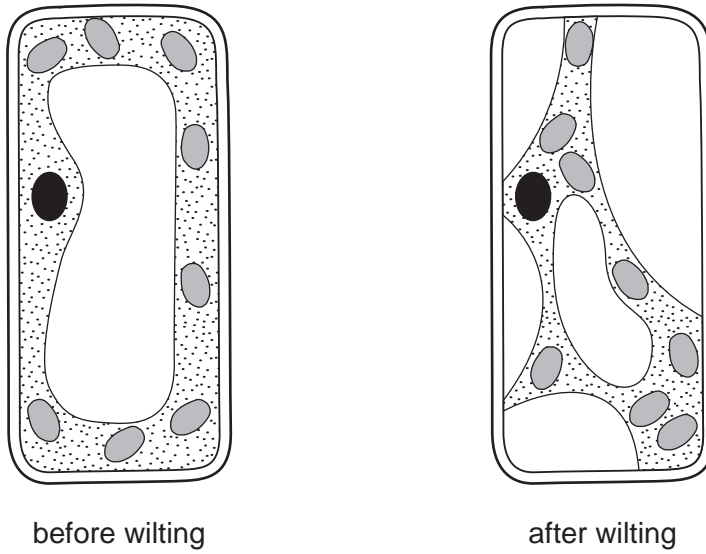

Fig. 9.2

- (i) On the diagram of the cell before wilting in Fig. 9.2, label and name **two** structures that would **not** be present in an animal cell. [2]
- (ii) Using your knowledge of osmosis, explain what happened to the plant cell to cause its appearance after the plant wilted.

.....

.....

.....

.....

..... [3]

