

**COMBINED SCIENCE**

**0653/52**

Paper 5 Practical Test

**May/June 2014**

**CONFIDENTIAL INSTRUCTIONS**

**Great care should be taken to ensure that any confidential information given does not reach the candidates either directly or indirectly.**

**The Supervisor's attention is drawn to the form on page 8 which must be completed and returned with the scripts.**

If you have any queries regarding these instructions, please contact CIE

by e-mail: [info@cie.org.uk](mailto:info@cie.org.uk)

by phone: +44 1223 553554

by fax: +44 1223 553558

stating the nature of the query and the syllabus number quoted above.

This document consists of 7 printed pages and 1 blank page.



## Instructions for preparing apparatus

These instructions detail the apparatus, reagents and specimens required by each candidate for the experiment in this paper. A summary of the questions that will be presented to the candidates is included, where appropriate, to allow the teacher to test the apparatus appropriately. **No access is permitted to the question paper in advance of the examination session.**

It is assumed that the ordinary apparatus of a science laboratory will be available, including a supply of purified water (distilled or deionised).

If arrangements are made for different sessions for different groups of candidates, care must be taken to ensure that the different groups of candidates are effectively isolated so that **no information passes between them.**

**All specimens should carry only the code letters and numbers as indicated and their identity should not be revealed to the candidates.**

Supervisors should ensure that all specimens have the correct identity attached to the specimen and that these are **not** removed during the examination.

If a candidate breaks any of the apparatus, or loses any of the material supplied, the matter should be rectified and a note made in the Supervisor's Report.

Supervisors are advised to remind candidates that **all** substances in the examination should be treated with caution. Only those tests described in the Question Paper should be attempted. Pipette fillers and safety goggles should be used where necessary.

In accordance with COSHH (Control of Substances Hazardous to Health) Regulations, operative in the UK, a hazard appraisal of the examination has been carried out.

The following codes are used where relevant.

**C** = corrosive substance

**F** = highly flammable substance

**H** = harmful or irritating substance

**O** = oxidising substance

**T** = toxic substance

**N** = harmful to the environment

The attention of Centres is drawn to any local regulations relating to safety, first-aid and disposal of chemicals.

'Hazard Data Sheets', relating to materials used in this examination, should be available from your chemical supplier.

The Supervisor should make sure the Supervisor's Report is fully completed and a copy is enclosed with each packet of scripts.

Centres are reminded that they are **not** permitted to open the question paper envelopes before the examination. Centres are also referred to the Handbook for Centres, the Security of Question Papers and Examination Materials section and the Practical Examinations in Science Subjects section.

If there are difficulties with any aspect of setting up this practical examination that the Centre is not able to resolve, it is essential, for Centres to contact the Product Manager as soon as possible by e-mail to [info@cie.org.uk](mailto:info@cie.org.uk), by phone to +44 1223 553554 or by fax to +44 1223 553558.

**For question 1**

Each candidate will require:

- (i) two blocks of agar jelly of dimensions approximately  $2\text{ cm} \times 2\text{ cm} \times 2\text{ cm}$  in a Petri dish (or similar)
- (ii) a white tile
- (iii) a scalpel or cutting blade
- (iv) a ruler graduated in mm
- (v) two  $100\text{ cm}^3$  beakers, suitable for use with hydrochloric acid
- (vi) forceps
- (vii) stopclock
- [H] (viii) about  $100\text{ cm}^3$  of approximately  $2\text{ mol dm}^{-3}$  hydrochloric acid, labelled **hydrochloric acid**
- (ix) permanent marker pen.

**Note:** To make the agar jelly:

1. Smear a small amount of oil around the base of a clean dish of at least 2 cm minimum depth, e.g. ice cube trays.
2. Dissolve 20 g of agar in  $1000\text{ cm}^3$  of deionised water. Mix thoroughly and heat almost to the boil. Stir frequently until the solution is clear.
- [N][H] 3. Remove from the heat and add  $10\text{ cm}^3$  of 1% phenolphthalein solution (1 g of phenolphthalein dissolved in  $100\text{ cm}^3$  of 95% ethanol) and  $20\text{ cm}^3$  of bench (approximately  $2\text{ mol dm}^{-3}$ ) ammonia solution.
4. The solution should be a strong purple colour. Add more ammonia solution if necessary.
5. Mix thoroughly and pour into the oiled dishes to a depth of 2 cm. Allow to cool and go solid. Cut into  $2\text{ cm} \times 2\text{ cm} \times 2\text{ cm}$  blocks immediately before the examination.

To store the prepared agar, place the dish in a sealed bag in a fridge with a small beaker of ammonia solution to maintain the alkaline conditions and purple colour.

**For question 2**

Each candidate will require:

- [H]**
- (i) approximately 3g of a solid mixture labelled **X**, containing equal masses of copper sulfate,  $\text{CuSO}_4 \cdot 5\text{H}_2\text{O}$  and iron(II) sulfate,  $\text{FeSO}_4 \cdot 7\text{H}_2\text{O}$ . The two solids should be thoroughly mixed and any large crystals crushed
  - (ii) a supply of distilled water (approximately  $40\text{ cm}^3$  is required), labelled **distilled water**
  - (iii) about  $10\text{ cm}^3$  of approximately  $0.1\text{ mol dm}^{-3}$  barium chloride solution, labelled **barium chloride**
- [N] [H]**
- (iv) about  $10\text{ cm}^3$  of approximately  $0.05\text{ mol dm}^{-3}$  silver nitrate solution, labelled **silver nitrate**
  - (v) about  $50\text{ cm}^3$  of approximately  $2\text{ mol dm}^{-3}$  ammonia solution, labelled **ammonia**
  - (vi) 3 test-tubes (125 mm x 15 mm)
  - (vii) 1 large test-tube (150 mm x 25 mm)
  - (viii) 1 hard glass test-tube (125 mm x 15 mm), identified as hard glass
  - (ix) spatula
  - (x) stirring rod
  - (xi) two  $100\text{ cm}^3$  beakers, one labelled **washings**
  - (xii) teat pipettes
  - (xiii) means of holding a test-tube
  - (xiv) filter funnel and filter paper
  - (xv) Bunsen burner, and means to light it
  - (xvi)  $50\text{ cm}^3$  (or  $100\text{ cm}^3$ ) measuring cylinder.

**For question 3**

Each candidate will require:

- (i) a d.c. power source of approximately 1.5V to 2V. If candidates are supplied with a power source of variable voltage output, the voltage should be set by the supervisor and fixed e.g. taped
- (ii) 2.5V, 0.2A lamp in a suitable holder
- (iii) voltmeter capable of measuring the supply p.d. with a minimum precision of 0.1 V
- (iv) ammeter capable of reading up to 1.0A with a minimum precision of 0.05A
- (v) switch. The switch may be an integral part of the power supply
- (vi) a wooden or plastic metre rule with a millimetre scale
- (vii) approximately 105 cm of straight, bare constantan wire of diameter 0.38 mm (28 swg) or 0.27 mm (32 swg), taped to a metre rule at two places (between the zero and 5.0 cm mark and between the 95.0 and 100.0 cm mark). The zero end of the wire is to be labelled **P**, and the other end is to be labelled **Q**
- (viii) a suitable terminal (e.g. a crocodile clip) attached to the constantan wire at end **P** of the metre rule, so that the lamp can be attached to the resistance wire
- (ix) sliding contact, labelled **C**. This may be a crocodile clip connected to a lead.

**Note:** The circuit shown in Fig. 3.1 below must be set up for the candidates. At changeover, check that the circuit is still connected correctly. If cells are used, check that they are adequately charged.

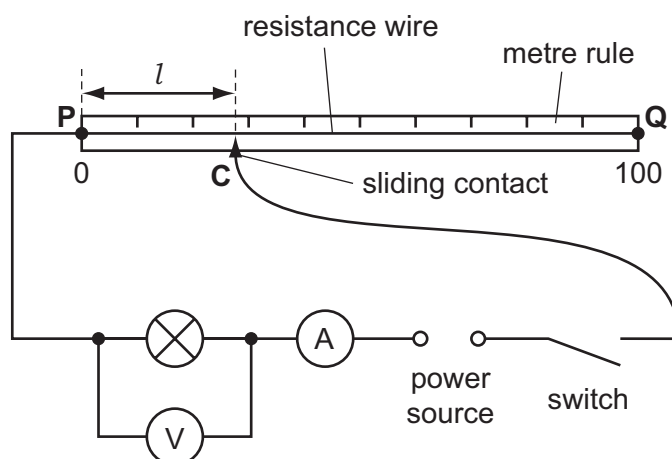

**Fig. 3.1**

Spare materials and equipment should be available and can be provided without penalty. **Candidates should be made aware of this.**

*Information required from the Supervisor:*

**The Supervisor is asked to carry out the experiments and to enter the results on a spare copy of the examination paper, clearly marked 'Supervisor's Results' and showing the Centre number. This should be done, out of sight of the candidates, using the same solutions, reagents, specimens and apparatus as the candidates.**

**A copy of the 'Supervisor's Results' should be returned with each packet of scripts. Failure to do so may cause the candidates to be penalised.**



This form must be completed and returned in the envelope with the scripts together with the seating plan and the Supervisor's Results as mentioned on page 6.

May/June 2014

*General*

The Supervisor is invited to give details of any difficulties experienced by particular candidates giving their names and candidate numbers. These should include reference to:

- (a) difficulties due to faulty apparatus;
- (b) accidents to apparatus or materials;
- (c) physical handicaps, e.g. short sight, colour blindness;
- (d) any other information that is likely to assist the Examiner, especially if this cannot be discovered in the scripts;
- (e) any help given to a candidate.

*The Supervisor is asked to supply the following information:*

Plan of work benches, giving details by candidate numbers of the places occupied by the candidates for each session and a copy of the 'Supervisor's Results'.

NAME OF CENTRE .....

SIGNED .....  
Supervisor

CENTRE NUMBER .....

DECLARATION (to be signed by the Principal)

The preparation of this practical examination has been carried out so as to maintain fully the security of the examination.

NAME .....  
(in block capitals)

SIGNED ..... (Principal)



Permission to reproduce items where third-party owned material protected by copyright is included has been sought and cleared where possible. Every reasonable effort has been made by the publisher (UCLES) to trace copyright holders, but if any items requiring clearance have unwittingly been included, the publisher will be pleased to make amends at the earliest possible opportunity.

Cambridge International Examinations is part of the Cambridge Assessment Group. Cambridge Assessment is the brand name of University of Cambridge Local Examinations Syndicate (UCLES), which is itself a department of the University of Cambridge.