

UNIVERSITY OF CAMBRIDGE INTERNATIONAL EXAMINATIONS
International General Certificate of Secondary Education

CO-ORDINATED SCIENCES

0654/05

Paper 5 Practical Test

May/June 2005

CONFIDENTIAL INSTRUCTIONS

Great care should be taken that any confidential information given does not reach the candidates either directly or indirectly.

The Supervisor's attention is drawn to the form on page 4 which must be completed and returned with the scripts.

If you have any queries regarding these Instructions, please contact CIE
by e-mail: International@ucles.org.uk,
by phone: +44 1223 553554,
by fax: +44 1223 553558,
stating the nature of the query and the syllabus number quoted above.

This document consists of 4 printed pages.



Instructions for preparing apparatus

These instructions detail the apparatus, reagents and specimens required by each candidate for the experiment in this paper. A summary of the questions that will be presented to the candidate is included, where appropriate, to allow the teacher to test the apparatus appropriately. **No access is permitted to the question paper in advance of the examination session.**

It is assumed that the ordinary apparatus of a science laboratory will be available, including a supply of purified water (distilled or deionised).

It is expected that candidates will have either a watch or sight of a clock with second hand.

If arrangements are made for different sessions for different groups of candidates, care must be taken to ensure that the different groups of candidates are effectively isolated so that **no information passes between them.**

For Question 1

Each candidate will require:

- (i) a flower from a dicotyledenous plant. The flower should have sepals. It should also have petals and stamens that can easily be removed intact;
- (ii) a white tile;
- (iii) a pair of tweezers;
- (iv) a ruler, graduated in mm;

For Question 2

Each candidate will require:

- (i) 2 wooden metre rules;
- (ii) a lump of plasticine or clay of suitable mass to give a deflection of at least 50 mm when added to the 950 mm mark on the ruler. See Fig.2.1 below;
- (iii) a means of clamping one of the metre rules to the bench, e.g. a G-clamp or any suitable mass, such as a brick. It may be helpful to provide some adhesive tape to hold the rule in fixed contact with the bench top.
- (iv) access to a balance capable of weighing to about 200 g to the nearest gram.

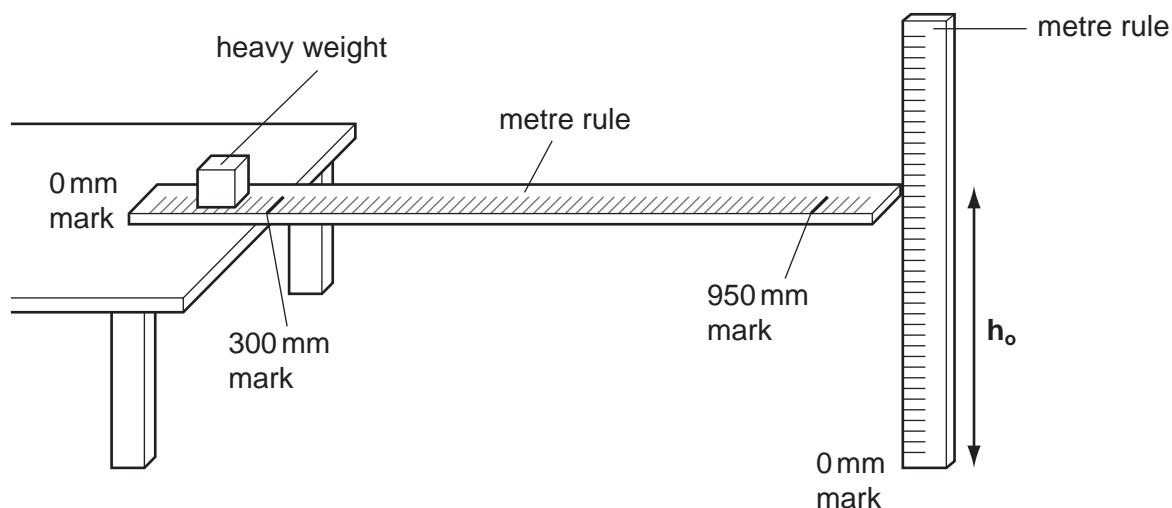

Fig. 2.1

Candidates will be required to fix a metre rule to the bench, see Fig. 2.1, and add lumps of metal to the rule producing a suitable deflection. If only plastic rules are available it will be necessary to check carefully (ii) above and state the use of such rulers in the information provided to the examiner.

For Question 3

Each candidate will require:

- (i) a 10 cm³ measuring cylinder;
- (ii) four test-tubes 125 x 15 mm;
- (iii) a test-tube rack;
- (iv) approximately 50 cm³ of hydrochloric acid of concentration 1 mol dm⁻³ (see note below);
- (v) a Bunsen burner;
- (vi) a wooden splint;
- (vii) a thermometer covering the range 0°C to 100°C;
- (viii) 1 g samples of each of the following metal powders:
 - iron, labelled metal **A**
 - zinc, labelled metal **B**
 - copper, labelled metal **D**
- (ix) 0.5 g of magnesium powder, labelled metal **C**;
- (x) a watch or sight of a clock with a second hand.

NB. The hydrochloric acid must be of sufficient concentration to cause a temperature change within 3 minutes when reacting with the zinc and iron.

Spare materials and equipment should be available and can be provided without penalty. **Candidates should be made aware of this.**

Information required from the Supervisor:

The Supervisor is asked to carry out the experiments and to enter the results on a spare copy of the examination paper, clearly marked 'Supervisor's Results' and showing the Centre number. This should be returned with the scripts. Failure to do so may cause the candidates to be penalised.

This form must be completed and returned in the envelope with the scripts together with the seating plan and the Supervisor's Results mentioned on page 3.

May/June 2005

General

The Supervisor is invited to give details of any difficulties experienced by particular candidates giving their names and candidate numbers. These should include reference to:

- (a) difficulties due to faulty apparatus;
- (b) accidents to apparatus or materials;
- (c) physical handicaps, e.g. short sight, colour blindness;
- (d) any other information that is likely to assist the Examiner, especially if this cannot be discovered in the scripts;
- (e) any help given to a candidate.

The Supervisor is asked to supply the following information:

Plan of work benches, giving details by candidate numbers of the places occupied by the candidates for each session and a copy of the 'Supervisor's Results'.

NAME OF CENTRE

SIGNED
Supervisor

CENTRE NUMBER

DECLARATION (to be signed by the Principal)

The preparation of this practical examination has been carried out so as to maintain fully the security of the examination.

NAME
(in block capitals)

SIGNED (Principal)

