



UNIVERSITY OF CAMBRIDGE INTERNATIONAL EXAMINATIONS
International General Certificate of Secondary Education

www.PapaCambridge.com

CO-ORDINATED SCIENCES

0654/01

Paper 1 Multiple Choice

May/June 2007

45 minutes

Additional Materials: Multiple Choice Answer Sheet
 Soft clean eraser
 Soft pencil (type B or HB is recommended)

* 2 5 2 6 5 6 0 1 0 9 *

READ THESE INSTRUCTIONS FIRST

Write in soft pencil.

Do not use staples, paper clips, highlighters, glue or correction fluid.

Write your name, Centre number and candidate number on the Answer Sheet in the spaces provided unless this has been done for you.

There are **forty** questions on this paper. Answer **all** questions. For each question there are four possible answers **A, B, C** and **D**.

Choose the **one** you consider correct and record your choice in **soft pencil** on the separate Answer Sheet.

Read the instructions on the Answer Sheet very carefully.

Each correct answer will score one mark. A mark will not be deducted for a wrong answer.

Any rough working should be done in this booklet.

A copy of the Periodic Table is printed on page 20.

This document consists of **17** printed pages and **3** blank pages.



1 Which system is used for naming and classifying living organisms?

- A binomial
- B biological
- C scientific
- D specific

2 The diagram shows a freshly cut potato chip, a chip suspended in liquid X and a chip suspended in liquid Y.

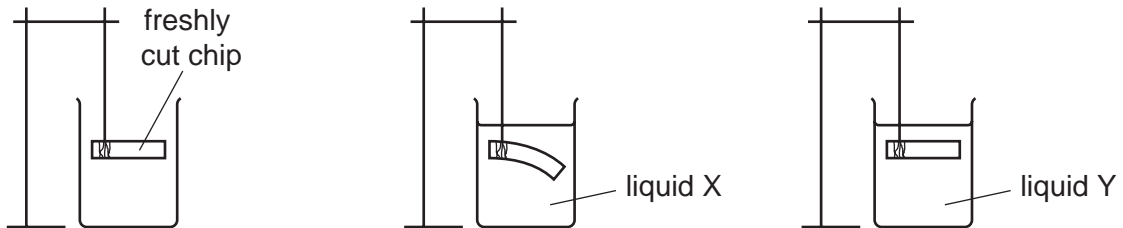

What identifies the liquids?

	liquid X	liquid Y
A	concentrated sugar solution	very dilute sugar solution
B	pure water	dilute sugar solution
C	dilute sugar solution	concentrated sugar solution
D	pure water	concentrated sugar solution

3 The diagram shows a synovial joint.

Which area contains synovial fluid?

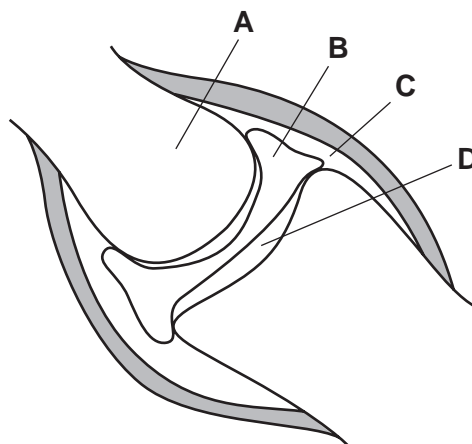

4 What is used to remove the colour from a leaf in the starch test?

- A alcohol (methylated spirits)
- B cold water
- C hot water
- D iodine solution

5 Which structures carry blood towards the heart?

	aorta	pulmonary artery	pulmonary vein	vena cava
A	✓	✓	x	x
B	✓	x	✓	x
C	x	✓	x	✓
D	x	x	✓	✓

6 When farm animals are kept for meat production they have a special diet to increase their muscle growth.

Which nutrient is increased in the diet?

- A carbohydrate
- B fat
- C protein
- D vitamins

7 The diagram shows how a large food molecule is changed into smaller molecules.

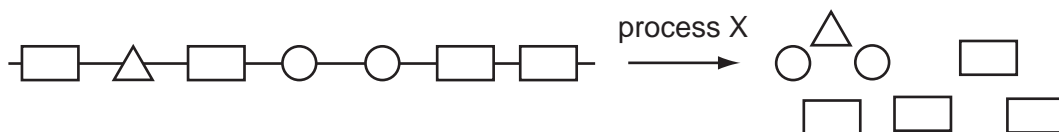

What is process X?

- A absorption
- B chewing
- C digestion
- D secretion

- 8 An elderly person has broken several bones. The doctor advises him to drink more milk. What is the reason for this advice?
- A Milk helps to prevent dehydration.
 - B Milk is a good source of calcium.
 - C Milk is a good source of iron.
 - D Milk is low in fat.
- 9 What is homeostasis?
- A the maintenance of the body's external environment
 - B the maintenance of the body's internal environment
 - C the processes that produce heat in the body
 - D the removal of wastes from the body
- 10 After a plant has produced flowers, what is the correct sequence of events leading to reproduction in that plant?
- A fertilisation, pollination, seed formation
 - B pollination, fertilisation, seed formation
 - C seed formation, fertilisation, pollination
 - D seed formation, pollination, fertilisation
- 11 What is the name of the organ in which a human baby grows until it is born?
- A ovary
 - B oviduct
 - C uterus
 - D vagina

- 12 The diagram shows the results of crossing two tall pea plants. T represents the dominant allele for tallness.

	T	t
T	TT	Tt
t	Tt	tt

What information can be obtained from this diagram?

- A The parent plants were heterozygous.
 B All the offspring are homozygous.
 C The shaded row shows the phenotypes of the parents.
 D The right hand column shows mutations.
- 13 What is released by decomposers from decaying organic matter?

- A carbohydrates
 B inorganic ions
 C oxygen
 D protein

- 14 When water is heated to 100°C, it changes to steam.

The steam has a larger volume than the water.

Which change on heating explains this increase in volume?

- A The bonds between hydrogen and oxygen break.
 B The molecules become lighter.
 C The spacing between the molecules increases.
 D The water molecules expand.
- 15 A silver coin contains the same number of atoms as a gold coin.

Is the mass, and number of electrons, the same for the two coins?

	mass	number of electrons
A	✓	✓
B	✓	x
C	x	✓
D	x	x

- 16 A small piece of element **X** is dropped into a bowl of water. The diagrams show what

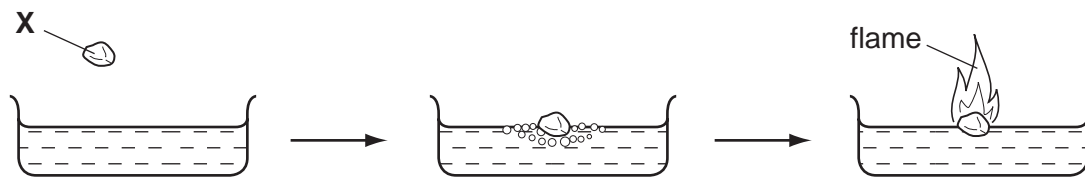

When the reaction stops, the remaining solution turns Universal Indicator blue.

To which group of the Periodic Table does element **X** belong?

- A** 1 **B** 3 **C** 5 **D** 6
- 17 The diagram shows some of the useful products manufactured in the chemical industry from substance X.

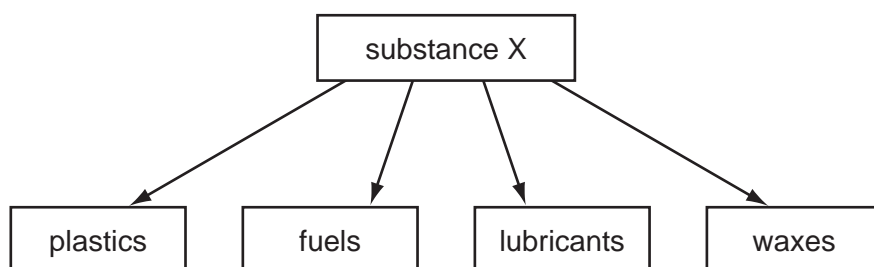

What is substance X?

- A** limestone
B methane
C petroleum
D salt

18 Which diagram shows how to separate glucose from a mixture of starch and glucose?

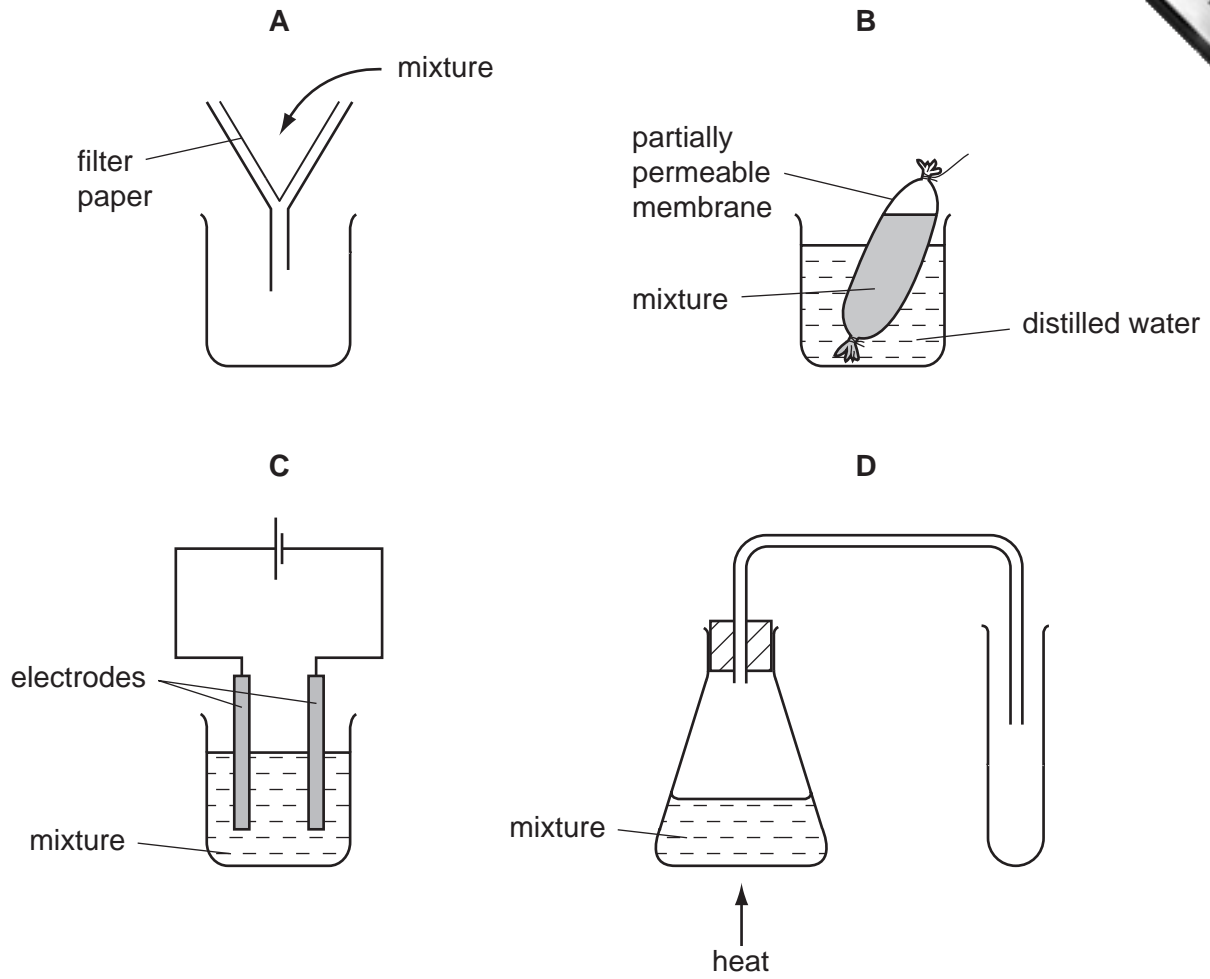

19 It is unusual for a hot drink to be served in a metal cup.

Why is this?

- A Metals are usually hard.
- B Metals are usually strong.
- C Metals have high porosity.
- D Metals have high thermal conductivity.

20 Neon and nitrogen are gaseous non-metals.

Which of these elements can be oxidised?

	neon	nitrogen
A	✓	✓
B	✓	x
C	x	✓
D	x	x

21 The gas from a leaking cylinder is tested by using damp litmus paper. The damp litmus paper is bleached.

What is the gas?

- A** ammonia
- B** chlorine
- C** hydrogen
- D** oxygen

22 The diagram shows the electrolysis of acidified water.

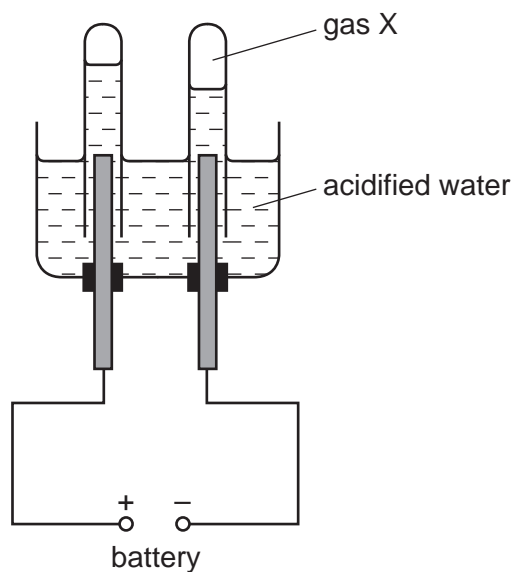

Gas X ignites with a pop when tested with a lighted splint.

What is gas X and at which electrode is it formed?

	X is	electrode
A	hydrogen	anode
B	hydrogen	cathode
C	oxygen	anode
D	oxygen	cathode

23 In the extraction of iron, its ore is first treated with sulphuric acid. This leaves a solid waste which contains unreacted acid.

The best way of treating this waste is to neutralise the acid.

How could this be done?

- A** by adding lime
- B** by adding rock salt
- C** by adding sand
- D** by adding water

24 The diagram shows apparatus used to investigate the reactivity of metals with a dilute

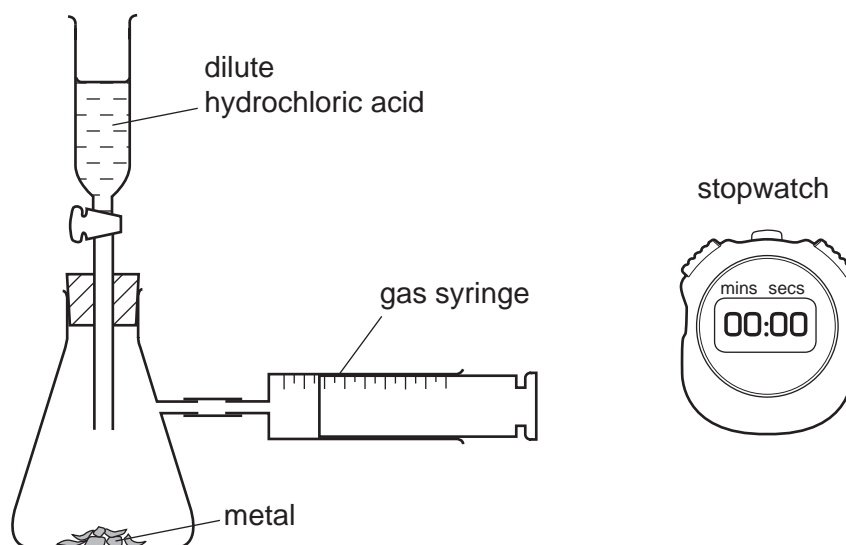

The experiment is repeated using an equal volume of the same acid each time, but changing the metal.

With which metal is the time taken to fill the syringe the shortest?

- A copper foil
- B copper powder
- C magnesium powder
- D magnesium ribbon

- 25 It is suggested that the colour of a dye fades over time because sunlight causes the dye to react with oxygen.

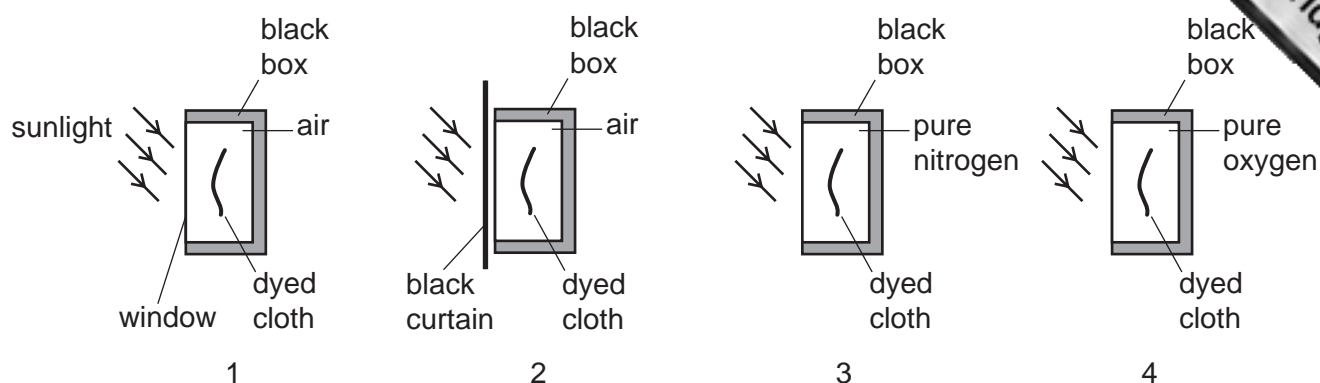

Which of the experiments shown would help test this suggestion?

	1	2	3	4
A	✓	✓	✓	✓
B	✓	✓	✓	x
C	✓	✓	x	✓
D	x	✓	✓	✓

- 26 In which form do plants receive essential elements from fertilisers?

- A** atoms
- B** carbohydrates
- C** ions
- D** proteins

- 27 Light is shone into four liquids in clear glass containers.

In which container is the light scattered?

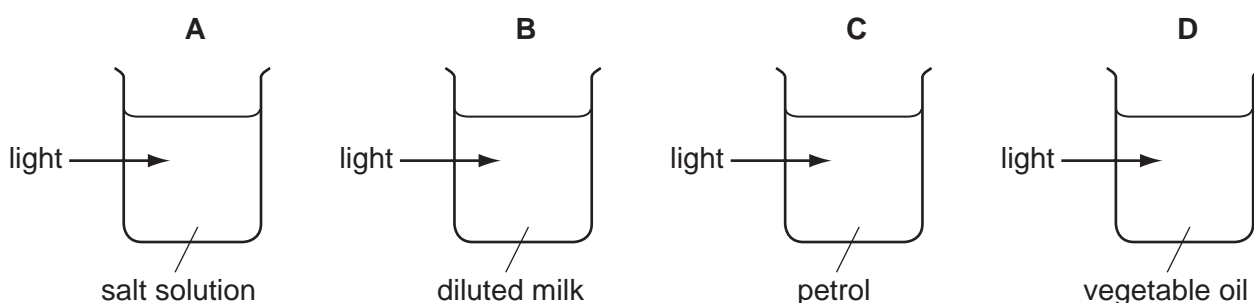

28 The diagram shows a bird in flight.

In which direction does the weight of the bird act?

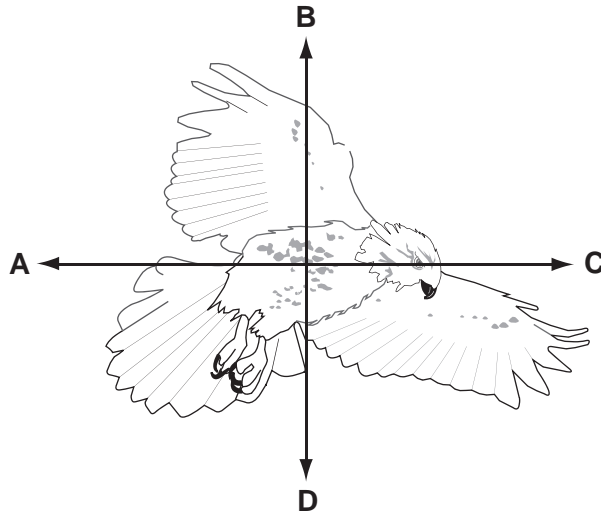

29 Each of the solids shown in the diagram has the same mass.

Which solid has the greatest density?

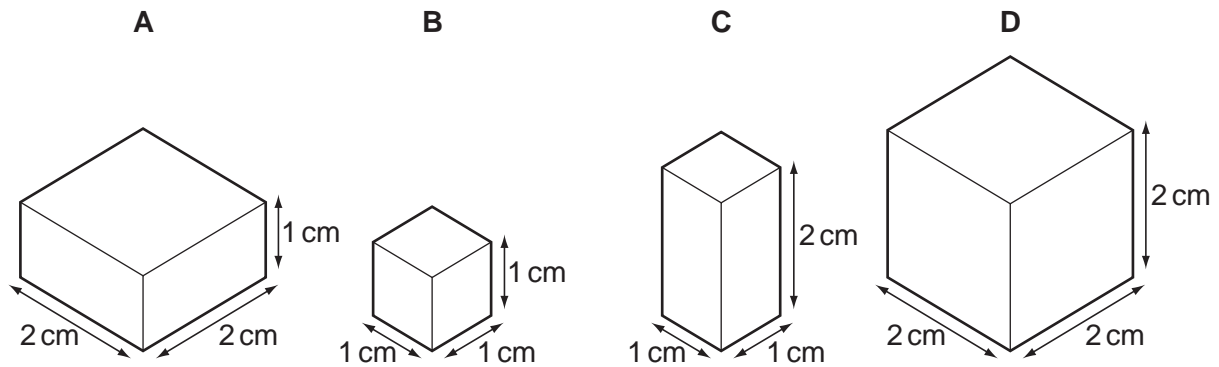

30 Which unit is used to measure work?

- A joule
- B kilogram
- C newton
- D watt

- 31 Meat can be cooked by placing it below, but not touching, a heating element.

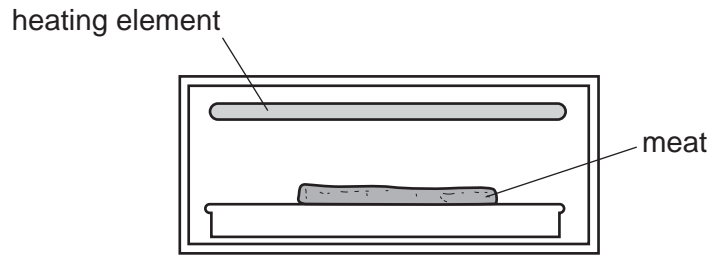

Which process transfers thermal energy from the heating element to the meat?

- A conduction
 - B convection
 - C insulation
 - D radiation
- 32 Water waves are reflected at a plane surface.
- Which property of the waves is changed by the reflection?

- A direction
- B frequency
- C speed
- D wavelength

- 33 A ray of light is reflected by two parallel plane mirrors X and Y.

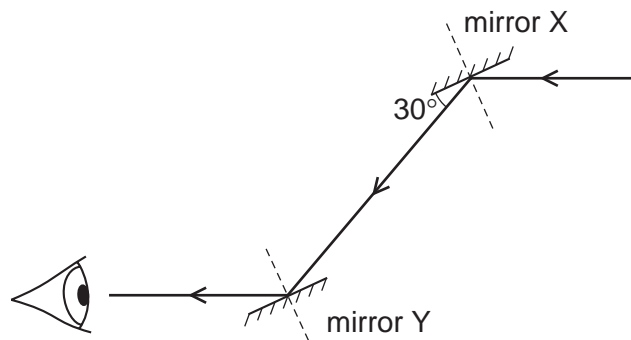

Which statement is correct?

- A The angle of incidence at mirror X is 30° .
- B The angle of incidence at mirror Y is 60° .
- C The angle of reflection at mirror X is 120° .
- D The angle of reflection at mirror Y is 0° .

34 Which circuit shows the correct use of a voltmeter in measuring the p.d. across the resistor?

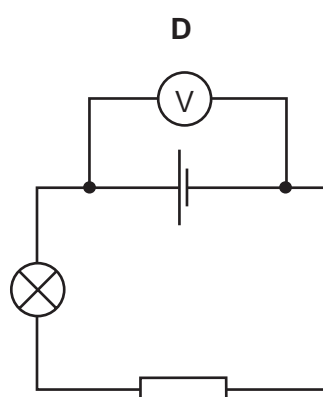
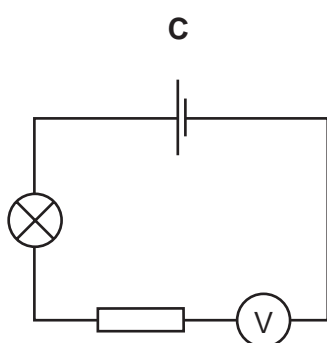
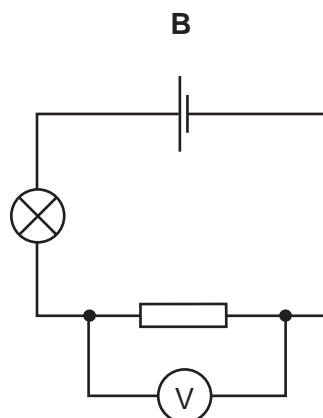
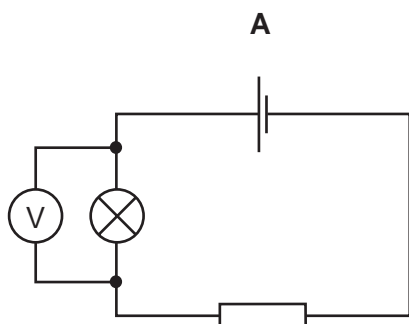

35 Four wires are made from the same material.

Which wire has the greatest resistance?

	length of wire / cm	diameter of wire / mm
A	50	0.1
B	50	0.2
C	100	0.1
D	100	0.2

36 A vehicle of mass 900 kg is travelling with a velocity of 20 m/s.

What is the momentum of the vehicle?

- A** 45 Ns **B** 450 Ns **C** 18 000 Ns **D** 180 000 Ns

37 The diagram, which is not to scale, shows the planets Mars and Earth.



Which statement is correct?

- A Earth repels Mars but Mars attracts Earth.
- B Earth attracts Mars but Mars repels Earth.
- C Earth and Mars attract each other.
- D Earth and Mars repel each other.

38 The list gives some ways of communicating.

- smoke signals, using a fire and blanket
- lighting fires on hill tops
- turning a torch on and off
- using flags on ships

What enables all these methods to work?

- A light and a code
- B light and infra-red waves
- C sound and a code
- D sound and infra-red waves

39 The diagram shows a thermionic diode.

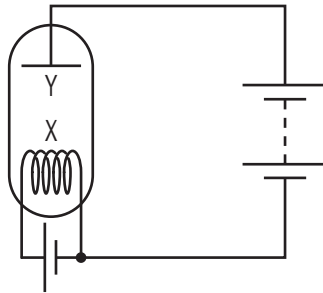

Which particles are emitted in the diode, and from where are they emitted?

	particles	from where emitted
A	electrons	X
B	electrons	Y
C	protons	X
D	protons	Y

40 The half-life of a radioactive substance is 5 hours. A sample is tested and found to contain 0.48 g of the substance.

How much of the substance was present in the sample 20 hours before the sample was tested?

- A** 0.03g **B** 0.12g **C** 1.92g **D** 7.68g

DATA SHEET
The Periodic Table of the Elements

		Group									
I	II	III	IV	V	VI	VII	VIII	IX	X	XI	XII
		1 H Hydrogen 1									
7 Li Lithium 3	9 Be Beryllium 4										
23 Na Sodium 11	24 Mg Magnesium 12										
39 K Potassium 19	40 Ca Calcium 20	51 V Vanadium 23	52 Cr Chromium 24	55 Mn Manganese 25	56 Fe Iron 26	59 Co Cobalt 27	59 Ni Nickel 28	64 Cu Copper 29	65 Zn Zinc 30	70 Ga Gallium 31	73 Ge Germanium 32
85 Rb Rubidium 37	88 Sr Strontium 38	91 Zr Zirconium 40	96 Mo Molybdenum 42	101 Ru Ruthenium 44	106 Pd Palladium 46	112 Cd Cadmium 48	115 In Indium 49	119 Sn Tin 50	122 Sb Antimony 51	128 Te Tellurium 52	131 Xe Xenon 54
133 Cs Caesium 55	137 Ba Barium 56	178 Hf Hafnium 72	184 W Tungsten 74	186 Re Rhenium 75	192 Ir Iridium 77	197 Au Gold 79	201 Hg Mercury 80	204 Tl Thallium 81	207 Pb Lead 82	209 Bi Bismuth 83	210 Po Polonium 84
226 Ra Radium 88	227 Ac Actinium 89	227 Fr Francium 87									

*58-71 Lanthanoid series

†90-103 Actinoid series

	a	X	b
Key	a = relative atomic mass	X = atomic symbol	b = proton (atomic) number

140 Ce Cerium 58	141 Pr Praseodymium 59	144 Nd Neodymium 60	150 Sm Samarium 62	152 Eu Europium 63	157 Gd Gadolinium 64	162 Dy Dysprosium 66	165 Ho Holmium 67	167 Er Erbium 68	169 Tm Thulium 69	173 Yb Ytterbium 70	175 Lu Lutetium 71
232 Th Thorium 90	238 Pa Protactinium 91	238 U Uranium 92	238 Pu Plutonium 94	95 Am Americium 95	96 Cm Curium 96	98 Cf Californium 98	99 Es Einsteinium 99	100 Fm Fermium 100	101 Md Mendelevium 101	102 No Nobelium 102	103 Lr Lawrencium 103

The volume of one mole of any gas is 24 dm³ at room temperature and pressure (r.t.p.).