



Cambridge IGCSE™

CANDIDATE
NAME

CENTRE
NUMBER

--	--	--	--	--

CANDIDATE
NUMBER

--	--	--	--



CO-ORDINATED SCIENCES

0654/42

Paper 4 Theory (Extended)

October/November 2022

2 hours

You must answer on the question paper.

No additional materials are needed.

INSTRUCTIONS

- Answer **all** questions.
- Use a black or dark blue pen. You may use an HB pencil for any diagrams or graphs.
- Write your name, centre number and candidate number in the boxes at the top of the page.
- Write your answer to each question in the space provided.
- Do **not** use an erasable pen or correction fluid.
- Do **not** write on any bar codes.
- You may use a calculator.
- You should show all your working and use appropriate units.

INFORMATION

- The total mark for this paper is 120.
- The number of marks for each question or part question is shown in brackets [].
- The Periodic Table is printed in the question paper.

This document has **28** pages. Any blank pages are indicated.

1 (a) The total number of new HIV infections in the world is monitored.

The results are shown in Fig. 1.1.

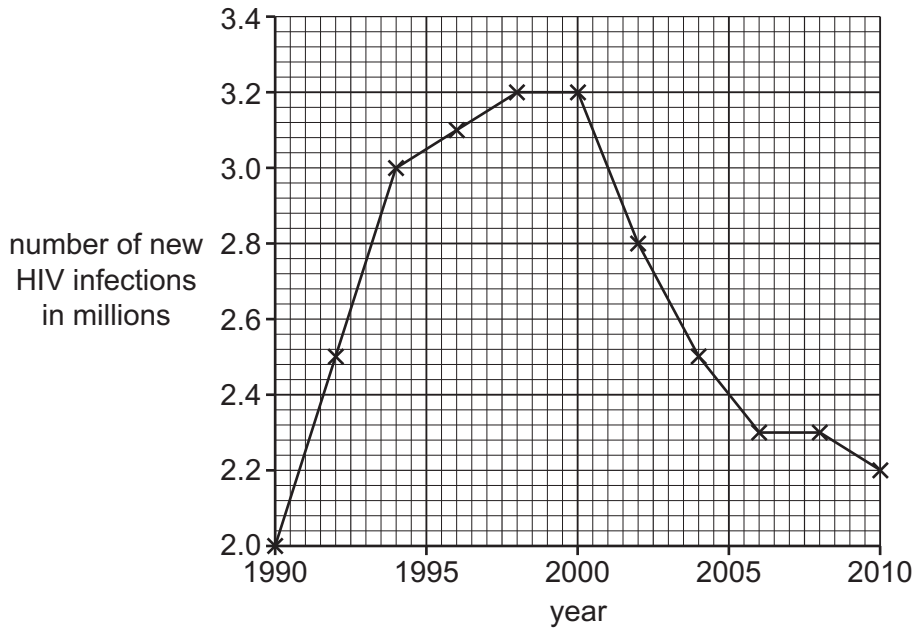

Fig. 1.1

(i) Calculate the percentage decrease in the number of new HIV infections between 2000 and 2010 as shown in Fig. 1.1.

decrease = % [2]

(ii) Suggest **three** reasons for the decrease in the number of new HIV infections.

.....

.....

.....

.....

..... [3]

(b) HIV is a virus that targets white blood cells.

(i) State **two** functions of white blood cells.

1

2

[2]

(ii) White blood cells are one component of blood.

State **two** other main components of blood.

1

2

[2]

(c) State the name of the barrier that protects the fetus from toxins in the mother's blood.

..... [1]

[Total: 10]

- 2 (a) Fig. 2.1 shows the atoms of some elements.

The letters do **not** represent the symbols of the elements.

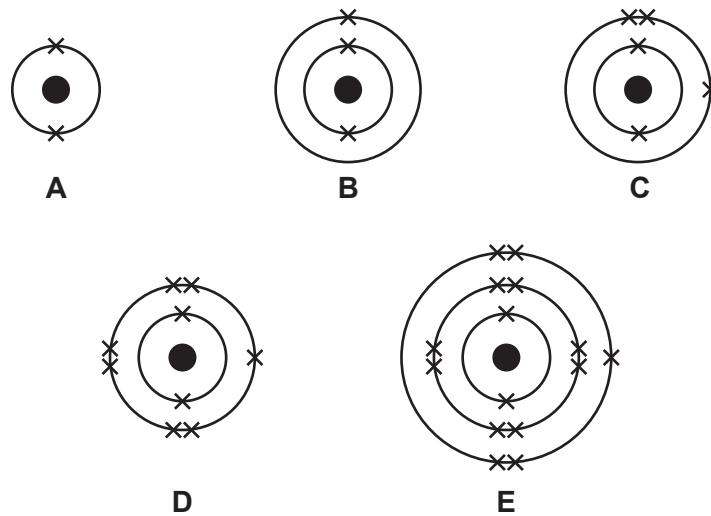

Fig. 2.1

- (i) State the evidence from Fig. 2.1 that shows that element **C** is in Group III of the Periodic Table.

..... [1]

- (ii) Identify which of the elements in Fig. 2.1 forms an ion with a charge of -3 .

Choose from **A**, **B**, **C**, **D** or **E**.

answer = [1]

- (iii) Write the electronic structure of element **E**.

..... [1]

- (iv) Identify which of the elements in Fig. 2.1 has a proton number (atomic number) of 9.

Choose from **A**, **B**, **C**, **D** or **E**.

answer = [1]

- (v) State the evidence from Fig. 2.1 that shows that element **A** is unreactive.

..... [1]

(vi) Elements **B** and **D** react together to form an ionic compound.

Draw a dot-and-cross diagram to show the ions formed when elements **B** and **D** react together.

Include the charges on the ions.

[2]

(vii) Ionic compounds have a lattice structure.

Describe the lattice structure of ionic compounds.

.....

 [2]

(b) The nucleus of an atom contains protons and neutrons.

Table 2.1 shows the relative charge and relative mass of a proton.

Complete the table to show the relative charge and relative mass of a neutron.

Table 2.1

	relative charge	relative mass
proton	+1	1
neutron		

[2]

[Total: 11]

- 3 Fig. 3.1 shows a man transporting some luggage in a small boat.



Fig. 3.1

- (a) Fig. 3.2 shows a distance–time graph for part of the journey.

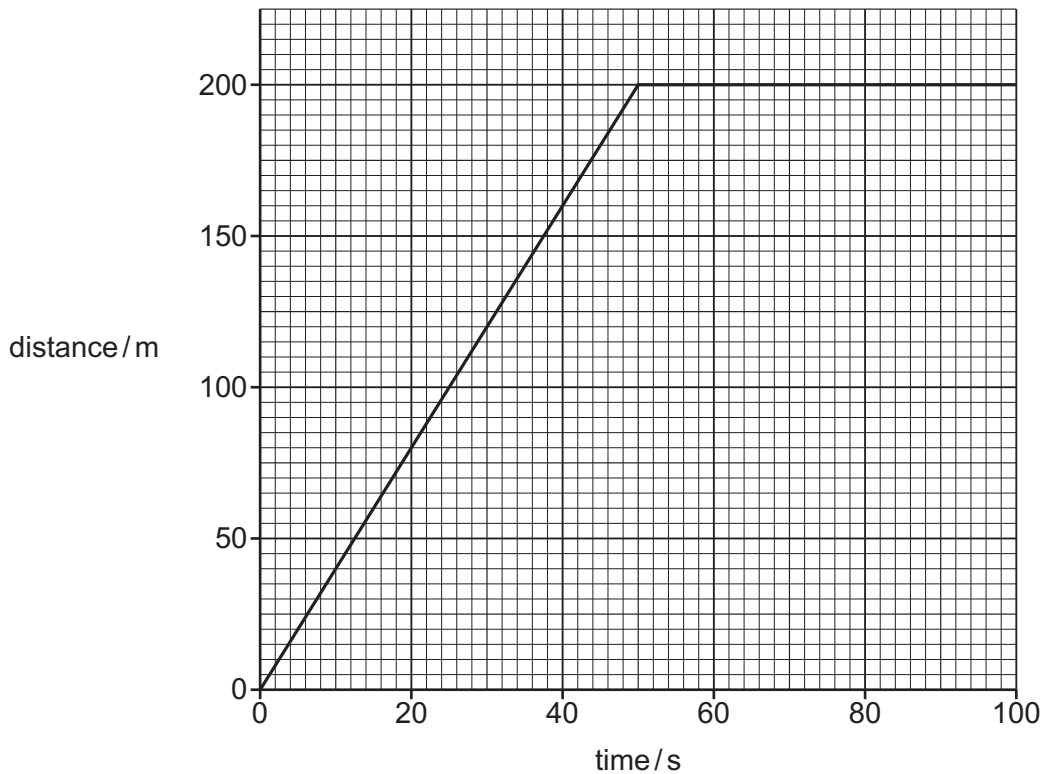

Fig. 3.2

- (i) Using data from the graph, describe the journey shown in Fig. 3.2.

.....

 [3]

- (ii) Show that the speed of the boat, 20 seconds after the start of the journey, is 4.0 m/s.

..... [1]

(iii) The combined mass of the man, his luggage and the small boat is 100 kg.

Calculate the total kinetic energy of the man, his luggage and the small boat when their speed reaches 4.0 m/s.

kinetic energy = J [2]

(b) The man lifts the boat off the water and attaches it to a trolley.

The man exerts a downwards force **F** which keeps the boat in equilibrium as shown in Fig. 3.3.

The wheels of the trolley act as a pivot.

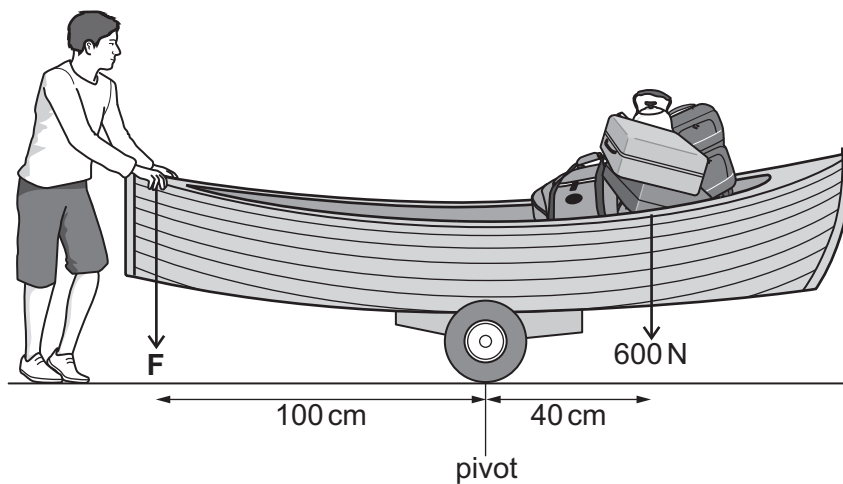

Fig. 3.3

Use the principle of moments to calculate the size of the force **F**.

force = N [3]

[Total: 9]

- 4 (a) A scientist tests the resistance of one strain of bacteria, to four different antibiotics, **A**, **B**, **C** and **D**.

Four paper discs, each soaked with a different antibiotic, are placed on an agar plate containing the bacteria.

The shaded areas show where the bacteria grow. The clear areas show where no bacteria grow.

Fig. 4.1 shows the results.

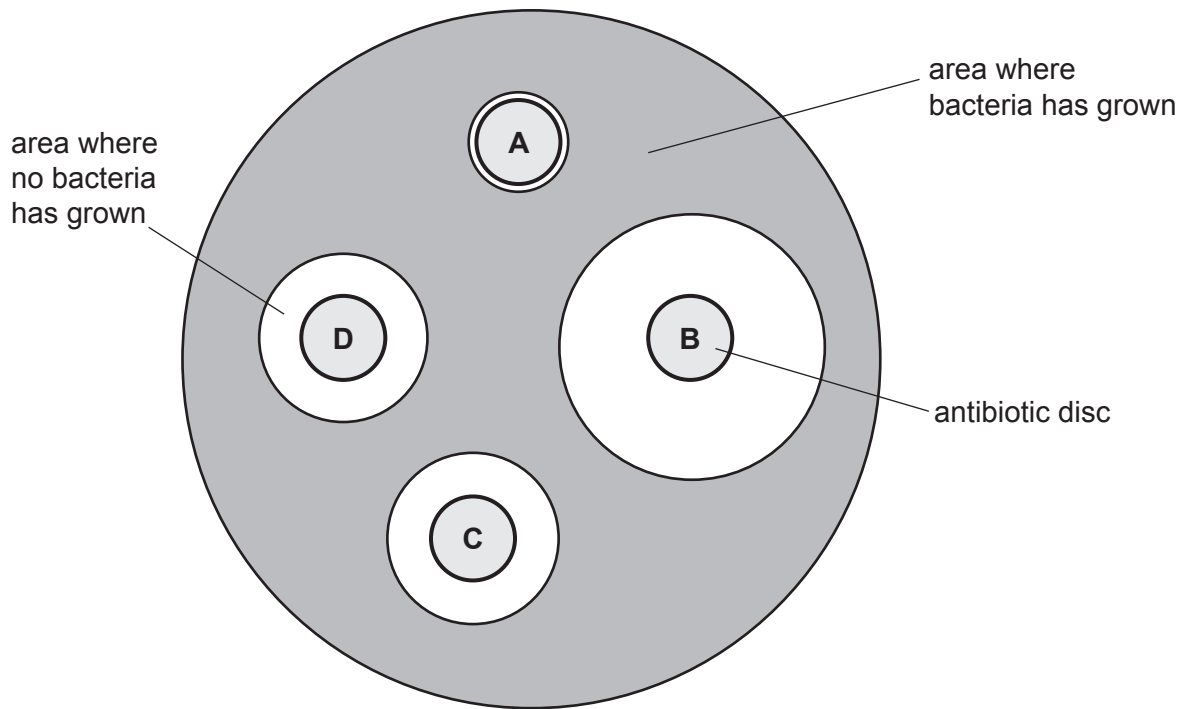

Fig. 4.1

- (i) Use Fig. 4.1 to identify the antibiotic that is the most effective against this strain of bacteria.

..... [1]

- (ii) Strains of bacteria develop antibiotic resistance due to natural selection.

Complete the sentences to describe how strains with antibiotic resistance develop.

Different strains of bacteria will show in their ability to resist antibiotics. When antibiotics are used some of the bacteria will survive and some will

.....

Those that survive will pass on their to the next generation.

The next generation will also show to antibiotics.

Eventually the whole population will have this feature.

[4]

(b) Natural selection results in evolution.

The box on the left contains the term evolution.

The boxes on the right show some sentence endings.

Draw **two** lines from the box on the left to make **two** correct sentences.

Evolution

causes a change in individual organisms.

occurs in bacteria only.

occurs in a single generation.

increases suitability to the environment.

is a change of adaptive features.

[2]

(c) Antibiotic resistance originates due to mutation.

(i) Define the term mutation.

.....
..... [1]

(ii) State the name of the type of radiation that increases the rate of mutation.

..... [1]

[Total: 9]

5 A scientist investigates a food colouring, **X**, using chromatography.

The scientist also analyses four known food colourings, **A**, **B**, **C** and **D**.

Fig. 5.1 shows the chromatogram produced. The result for food colouring **D** is **not** shown.

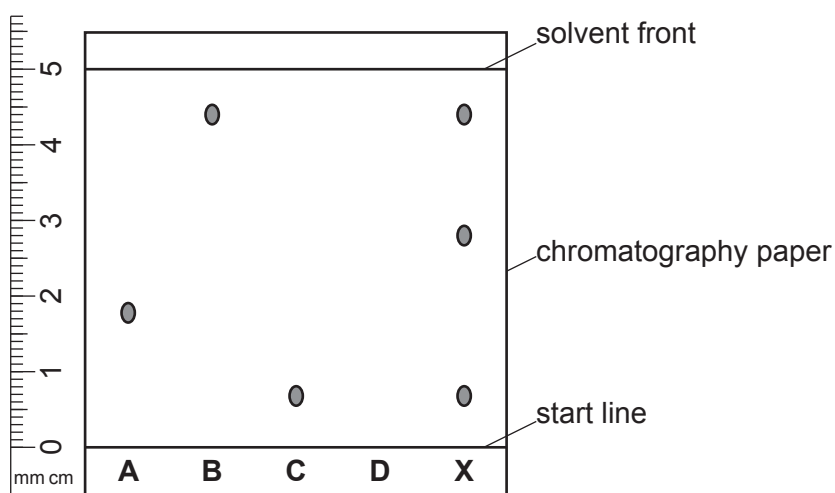

Fig. 5.1

(a) The R_f value of a food colouring is calculated using the formula:

$$R_f = \frac{\text{distance travelled by substance}}{\text{distance travelled by solvent}}$$

Calculate the R_f value of food colouring **B**.

Show your working.

R_f value = [2]

(b) Food colouring **D** has an R_f value of 0.56.

Calculate the distance travelled by food colouring **D**.

distance = cm [2]

(c) State which food colouring, **A**, **B** or **C**, is **not** in food colouring **X**.

..... [1]

(d) The scientist also investigates the purity of four substances, **V**, **W**, **Y** and **Z**.

Table 5.1 shows the melting point of each substance.

Table 5.1

substance	melting point/°C
V	98
W	92 – 95
Y	82
Z	102 – 104

State which of the substances are pure.

.....

Explain your answer.

.....

..... [2]

(e) The scientist dissolves 4.8 g of a substance in 250 cm³ of distilled water.

The relative molecular mass, M_r , of the substance is 192.

Calculate the concentration of the solution in **mol/dm³**.

concentration = mol/dm³ [3]

[Total: 10]

6 Fig. 6.1 shows a temporary zebra enclosure in a wildlife conservation park.

The enclosure is surrounded by an electric fence.

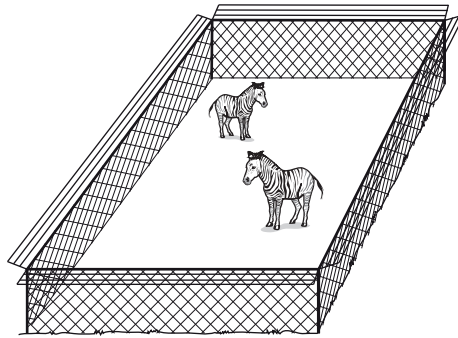

Fig. 6.1

(a) The fence is powered by an e.m.f. of 2000 V and carries a current of 80 mA.

(i) Calculate the total resistance of the fence.

total resistance = Ω [3]

(ii) The fence is made of two identical cables connected in parallel. The cables act as resistors.

Fig. 6.2 shows the circuit used in the electric fence.

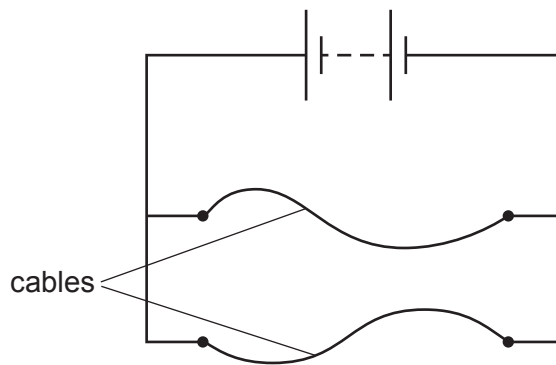

Fig. 6.2

Use your answer to **6(a)(i)** to calculate the resistance of **one** of the cables.

resistance = Ω [2]

- (iii) A different enclosure uses a fence made of cables that are the same thickness but twice the length of those shown in Fig. 6.1.

State the effect of doubling the cable length on the resistance of the fence.

..... [1]

- (b) One of the zebras is startled by a loud sound.

- (i) Describe how sound waves are transmitted in air.

.....
..... [1]

- (ii) After hearing the sound, the zebra runs across the enclosure in 7.5s. The average speed of the zebra is 16m/s.

Calculate the distance the zebra runs.

distance = m [2]

- (c) Fig. 6.3 shows one of the zebras in the enclosure.

The zebra has black and white stripes.

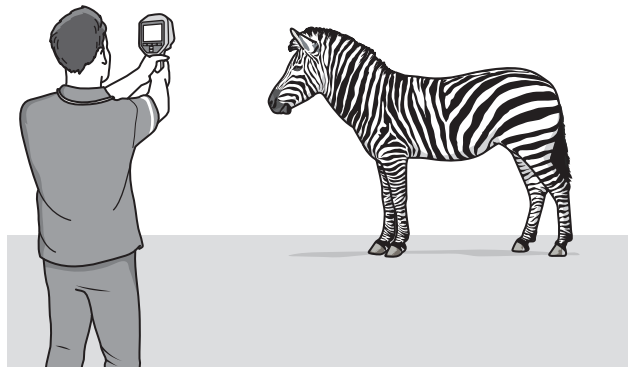

Fig. 6.3

A vet uses an infrared camera to measure the temperature of the zebra.

The infrared camera shows that the black stripes are a different temperature to the white parts of the zebra.

Describe and explain the difference in temperature recorded.

.....
.....
.....
..... [2]

7 Discarded rubbish pollutes ecosystems such as oceans and rivers.

(a) A student has written a definition of an ecosystem.

Their definition is **not** correct.

Circle the **two** words in their definition that are **not** correct.

'An ecosystem is a unit containing all of the organisms and their offspring, interacting together, in a given time.'

[2]

(b) Several countries estimate the average mass of discarded rubbish per person per day.

Fig. 7.1 shows the results.

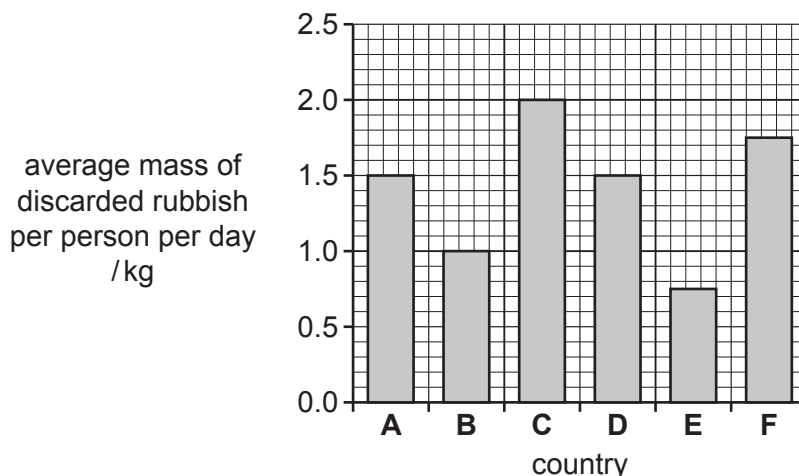

Fig. 7.1

(i) State which one of the countries in Fig. 7.1 discards the most rubbish per person per day.

..... [1]

(ii) State the average mass of discarded rubbish per person per day in country E.

..... kg [1]

(c) Pollution from excess use of fertilisers may cause eutrophication in rivers and lakes.

Part of the process of eutrophication is an increase in the number of surface producers and the death of underwater producers.

(i) Describe how an increase in the number of surface producers causes underwater producers to die.

.....
.....
..... [2]

(ii) Explain how the death of underwater producers causes the death of aquatic animals.

.....
.....
.....
..... [3]

[Total: 9]

8 A student investigates acids and bases.

(a) (i) The student tests the pH of dilute sulfuric acid, H_2SO_4 , using Universal Indicator.

Suggest the pH of the dilute sulfuric acid.

pH = [1]

(ii) The student tests aqueous sodium hydroxide, NaOH , with red litmus paper.

State what the student observes.

.....
 [1]

(iii) The student reacts dilute sulfuric acid with aqueous sodium hydroxide.

Sodium sulfate, Na_2SO_4 , and water are made.

Construct the balanced symbol equation for this reaction.

..... [2]

(b) When acids and bases react protons, H^+ , are transferred.

Define an acid in terms of proton transfer.

..... [1]

(c) The student makes up a solution of dilute sulfuric acid, H_2SO_4 , with a concentration of 0.2 mol/dm^3 .

Calculate the concentration of the solution in g/dm^3 .

[A_r : H, 1; O, 16; S, 32]

concentration = g/dm^3 [2]

(d) Sulfuric acid is made by the Contact process.

The equations for the stages in the Contact process are shown.

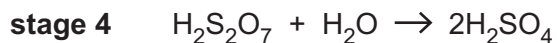
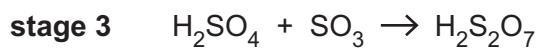
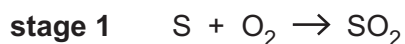

(i) Write the balanced symbol equation for the reaction in **stage 2**.

..... [2]

(ii) A pressure of 2 atmospheres is one of the conditions chosen for **stage 2**.

State **two** other conditions chosen for **stage 2**.

1

2

[2]

[Total: 11]

9 Burning coal can be used to generate electricity.

(a) State **one** advantage and **one** disadvantage of using coal to generate electricity.

advantage

.....

disadvantage

..... [2]

(b) The thermal energy released by the coal is used to turn liquid water into steam.

(i) Compare the:

- forces between molecules
- distances between molecules
- motions of molecules

in a liquid at 100 °C and a gas at 100 °C.

forces between molecules

.....

distances between molecules

.....

motions of molecules

.....

..... [3]

(ii) Complete Table 9.1 to describe what happens to the pressure in a sample of steam under different conditions. Assume the steam remains as a gas under each set of conditions.

Use the words **increases**, **decreases** or **remains constant**.

You can use each word once, more than once or not at all.

Table 9.1

temperature	volume	pressure
increases	remains constant	
decreases	remains constant	
remains constant	increases	
remains constant	decreases	

[2]

- (c) A transformer is used to change the potential difference of the output from a coal-fired power station.

The transformer is made up of a primary coil and a secondary coil, wrapped around an iron core.

- (i) The potential difference across the primary coil is 20 kV. The primary coil contains 120 turns. The potential difference across the secondary coil is 400 kV.

Calculate the number of turns on the secondary coil.

number of turns = [2]

- (ii) The electric power is transported from the power station over large distances at 400 kV. This is a very high potential difference.

Explain why a very high potential difference is used.

.....
.....
.....
.....
..... [2]

[Total: 11]

10 (a) Fig. 10.1 is a diagram of a cross-section through a leaf.

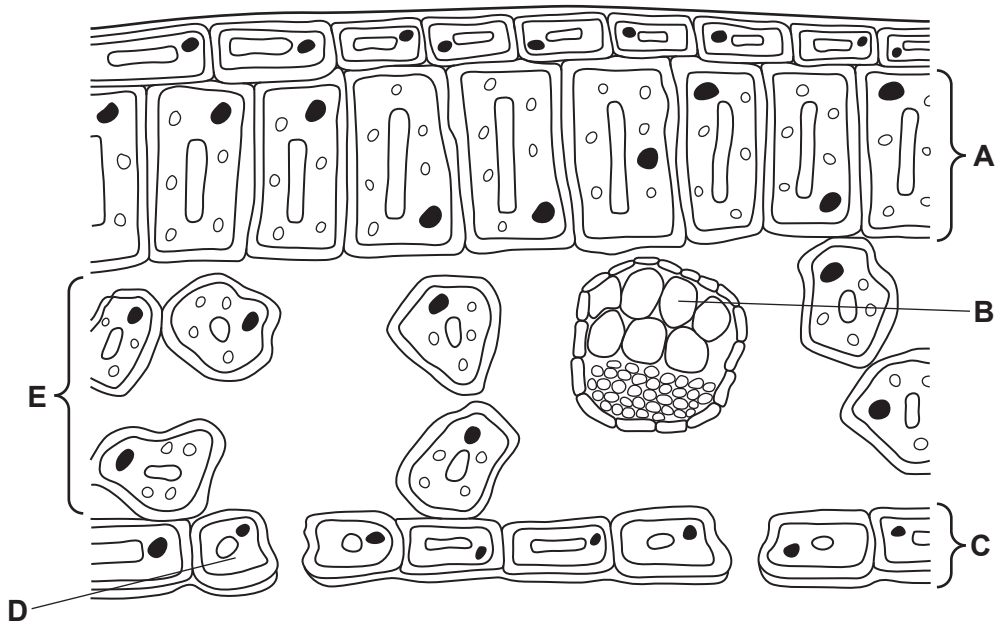

Fig. 10.1

- (i) Use Fig. 10.1 to identify the letter that represents the part:
- that provides structural support for the leaf
 - that transports mineral ions
 - where most photosynthesis occurs
 - that controls gas exchange. [4]

(ii) Draw a circle around the vascular bundle in Fig. 10.1. [1]

(b) Phloem is responsible for translocation.

- (i) Circle the **two** main substances transported by phloem.
- | | | | |
|-------------|-------------|---------|-----|
| amino acids | fatty acids | glucose | |
| glycogen | starch | sucrose | [2] |

(ii) Translocation occurs from source to sink.

State which of these regions in a plant acts as a source and which as a sink.

- region of growth
- region of production
- region of storage [2]

(c) Gas exchange occurs in both plants and animals.

(i) State the chemical formula of the gas that is required for photosynthesis.

..... [1]

(ii) State **two** features of gas exchange surfaces in humans.

1

2

[2]

[Total: 12]

- 11 Ethane and ethene are members of two different homologous series.

Fig. 11.1 shows the structure of ethene.

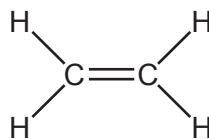

Fig. 11.1

- (a) Draw the structure of ethane.

[1]

- (b) Ethene is a member of the homologous series called the alkenes.

The alkenes are all hydrocarbons.

State **two** other features that the alkenes in the homologous series have in common.

1

2

[2]

- (c) Ethene undergoes an addition reaction with steam.

Fig. 11.2 shows the equation for the reaction.

Complete the equation, by drawing the structure of the compound formed.

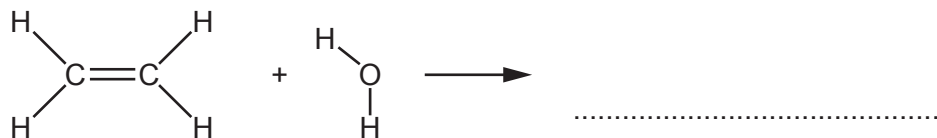

Fig. 11.2

[1]

(d) Propene is another alkene.

Fig. 11.3 shows the structure of propene.

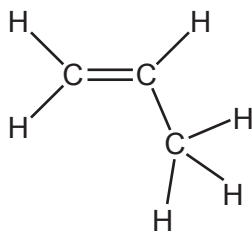

Fig. 11.3

The polymer poly(propene) can be made from propene.

Complete the structure of poly(propene) in Fig. 11.4. Include all the atoms and bonds of the repeating unit.

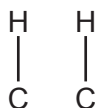

Fig. 11.4

[2]

(e) Poly(propene) is made from propene in an addition polymerisation reaction.

Polyesters are a group of polymers made in a condensation polymerisation reaction.

Describe the differences between addition polymerisation and condensation polymerisation.

.....

.....

.....

..... [2]

[Total: 8]

- 12 Fig. 12.1 shows the equipment used by a teacher to demonstrate the properties of ionising radiation.

The teacher uses a source which emits α -particles and a thick lead shield placed between the radioactive source and the radiation detector.

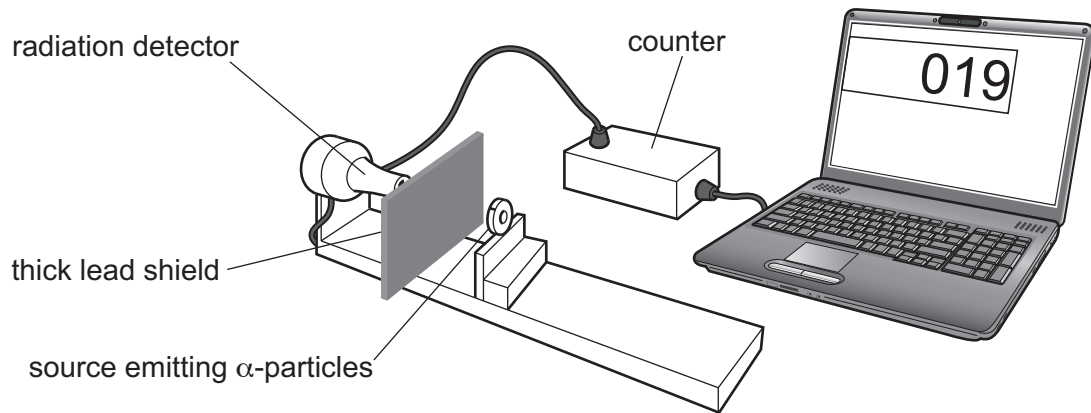

Fig. 12.1

- (a) (i) Explain why the count rate recorded by the laptop is low but not zero.

.....

.....

.....

..... [2]

- (ii) The teacher replaces the source emitting α -particles with a source that emits γ -rays. The count rate recorded by the laptop increases.

Suggest why the count rate recorded by the laptop increases.

.....

..... [1]

- (b) Before performing the investigation, the teacher uses a plane mirror to inspect the condition of the radioactive source.
- (i) Complete Fig. 12.2, with a ray diagram, to show how the mirror allows the teacher to see the radioactive source.

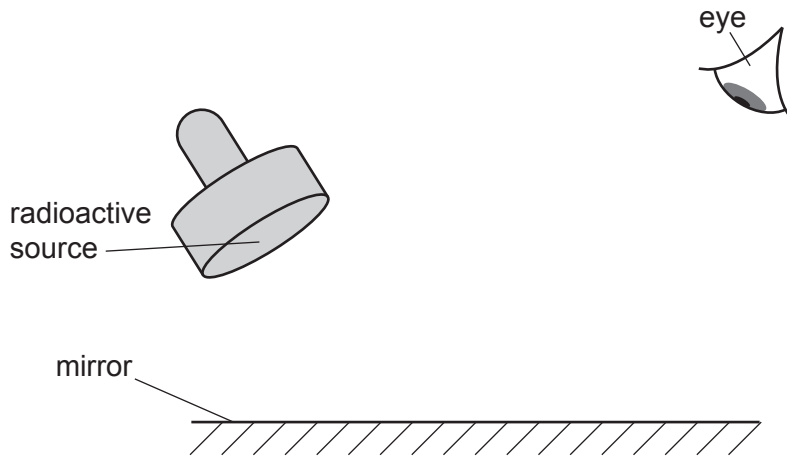

Fig. 12.2

[2]

- (ii) Visible light is an example of a transverse wave.

State what is meant by a transverse wave.

.....

.....

..... [2]

- (iii) A visible light wave travels at 3.0×10^8 m/s and has a frequency of 5.0×10^{14} Hz.

Calculate the wavelength of the visible light wave.

wavelength = m [2]

[Total: 9]

BLANK PAGE

Permission to reproduce items where third-party owned material protected by copyright is included has been sought and cleared where possible. Every reasonable effort has been made by the publisher (UCLES) to trace copyright holders, but if any items requiring clearance have unwittingly been included, the publisher will be pleased to make amends at the earliest possible opportunity.

To avoid the issue of disclosure of answer-related information to candidates, all copyright acknowledgements are reproduced online in the Cambridge Assessment International Education Copyright Acknowledgements Booklet. This is produced for each series of examinations and is freely available to download at www.cambridgeinternational.org after the live examination series.

Cambridge Assessment International Education is part of Cambridge Assessment. Cambridge Assessment is the brand name of the University of Cambridge Local Examinations Syndicate (UCLES), which is a department of the University of Cambridge.

The Periodic Table of Elements

		Group																
I	II	III	IV	V	VI	VII	VIII						VIII					
3 Li lithium 7	4 Be beryllium 9	1 H hydrogen 1	5 B boron 11	6 C carbon 12	7 N nitrogen 14	8 O oxygen 16	9 F fluorine 19	2 He helium 4						10 Ne neon 20				
11 Na sodium 23	12 Mg magnesium 24	<p>Key</p> <p>atomic number</p> <p>atomic symbol</p> <p>name</p> <p>relative atomic mass</p>											13 Al aluminium 27	14 Si silicon 28	15 P phosphorus 31	16 S sulfur 32	17 Cl chlorine 35.5	18 Ar argon 40
19 K potassium 39	20 Ca calcium 40												21 Sc scandium 45	22 Ti titanium 48	23 V vanadium 51	24 Cr chromium 52	25 Mn manganese 55	26 Fe iron 56
37 Rb rubidium 85	38 Sr strontium 88	39 Y yttrium 89	40 Zr zirconium 91	41 Nb niobium 93	42 Mo molybdenum 96	43 Tc technetium —	44 Ru ruthenium 101	45 Rh rhodium 103	46 Pd palladium 106	47 Ag silver 108	48 Cd cadmium 112	49 In indium 115	50 Sn tin 119	51 Sb antimony 122	52 Te tellurium 128	53 I iodine 127	54 Xe xenon 131	
55 Cs caesium 133	56 Ba barium 137	57–71 lanthanoids	72 Hf hafnium 178	73 Ta tantalum 181	74 W tungsten 184	75 Re rhenium 186	76 Os osmium 190	77 Ir iridium 192	78 Pt platinum 195	79 Au gold 197	80 Hg mercury 201	81 Tl thallium 204	82 Pb lead 207	83 Bi bismuth 209	84 Po polonium —	85 At astatine —	86 Rn radon —	
87 Fr francium —	88 Ra radium —	89–103 actinoids	104 Rf rutherfordium —	105 Db dubnium —	106 Sg seaborgium —	107 Bh bohrium —	108 Hs hassium —	109 Mt meitnerium —	110 Ds darmstadtium —	111 Rg roentgenium —	112 Cn copernicium —	114 Fl flerovium —	116 Lv livermorium —					

57 La lanthanum 139	58 Ce cerium 140	59 Pr praseodymium 141	60 Nd neodymium 144	61 Pm promethium —	62 Sm samarium 150	63 Eu europium 152	64 Gd gadolinium 157	65 Tb terbium 159	66 Dy dysprosium 163	67 Ho holmium 165	68 Er erbium 167	69 Tm thulium 169	70 Yb ytterbium 173	71 Lu lutetium 175
89 Ac actinium —	90 Th thorium 232	91 Pa protactinium 231	92 U uranium 238	93 Np neptunium —	94 Pu plutonium —	95 Am americium —	96 Cm curium —	97 Bk berkelium —	98 Cf californium —	99 Es einsteinium —	100 Fm fermium —	101 Md mendelevium —	102 No nobelium —	103 Lr lawrencium —

lanthanoids

actinoids

The volume of one mole of any gas is 24 dm³ at room temperature and pressure (r.t.p.).