



Cambridge IGCSE™

CO-ORDINATED SCIENCES

0654/52

Paper 5 Practical Test

May/June 2024

CONFIDENTIAL INSTRUCTIONS

This document gives details of how to prepare for and administer the practical exam.

The information in this document and the identity of any materials supplied by Cambridge International are confidential and must NOT reach candidates either directly or indirectly.

The supervisor must complete the report at the end of this document and return it with the scripts.

INSTRUCTIONS

- If you have any queries regarding these confidential instructions, contact Cambridge International stating the centre number, the syllabus and component number and the nature of the query.
email info@cambridgeinternational.org
phone +44 1223 553554

This document has **12** pages. Any blank pages are indicated.

General information about practical exams

Centres must follow the guidance on science practical exams given in the *Cambridge Handbook*.

Safety

Supervisors must follow national and local regulations relating to safety and first aid.

Only those procedures described in the question paper should be attempted.

Supervisors must inform candidates that materials and apparatus used in the exam should be treated with caution. Suitable eye protection should be used where necessary.

The following hazard codes are used in these confidential instructions, where relevant:

C	corrosive	MH	moderate hazard
HH	health hazard	T	acutely toxic
F	flammable	O	oxidising
N	hazardous to the aquatic environment		

Hazard data sheets relating to substances used in this exam should be available from your chemical supplier.

Before the exam

- The packets containing the question papers must **not** be opened before the exam.
- It is assumed that standard school laboratory facilities, as indicated in the *Guide to Planning Practical Science*, will be available.
- Spare materials and apparatus for the tasks set must be available for candidates, if required.

During the exam

- It must be made clear to candidates at the start of the exam that they may request spare materials and apparatus for the tasks set.
- Where specified, the supervisor **must** perform the experiments and record the results as instructed. This must be done **out of sight** of the candidates, using the same materials and apparatus as the candidates.
- Any assistance provided to candidates must be recorded in the supervisor's report.
- If any materials or apparatus need to be replaced, for example, in the event of breakage or loss, this must be recorded in the supervisor's report.

After the exam

- The supervisor must complete a report for each practical session held and each laboratory used.
- Each packet of scripts returned to Cambridge International must contain the following items:
 - the scripts of the candidates specified on the bar code label provided
 - the supervisor's results relevant to these candidates
 - the supervisor's reports relevant to these candidates
 - seating plans for each practical session, referring to each candidate by candidate number
 - the attendance register.

Specific information for this practical exam

During the exam, the supervisor (**not** the invigilator) must do the experiments in Questions 1, 2, 3, 5 and 6 and record the results on a spare copy of the question paper, clearly labelled 'supervisor's results'.

Question 1

Each candidate should be provided with:

hazard	materials and apparatus	quantity per candidate
	test-tubes (approximately 125 mm × 16 mm) and a means to support them	5
	means of labelling glassware	
	2 cm ³ syringe without needle	1
	1 cm ³ syringe without needle	5
[MH]	access to Benedict's solution labelled Benedict's solution (see note 1)	
	access to a hot water-bath at about 80 °C (see note 2)	
	distilled/deionised water in a container labelled 0.0% (see note 3)	5 cm ³
	3 g dm ⁻³ aqueous glucose in a container labelled solution S (see note 3)	5 cm ³
	5 g dm ⁻³ aqueous glucose in a container labelled 0.5% (see note 3)	5 cm ³
	10 g dm ⁻³ aqueous glucose in a container labelled 1.0% (see note 3)	5 cm ³
	20 g dm ⁻³ aqueous glucose in a container labelled 2.0% (see note 3)	5 cm ³
	stop-clock	1
	test-tube holder	1
	paper towels	3

Notes

1. The container for the Benedict's solution should allow access by a 2 cm³ syringe.
2. The hot water-bath will need to hold all five test-tubes at the same time. Candidates should be warned of the dangers of burns or scalds when using very hot water.
3. The containers for the water and aqueous glucose should allow access by a 1 cm³ syringe. To make up the solutions, powdered glucose can be dissolved in distilled/deionised water according to the units e.g. for solution **S**, 3g of powdered glucose is dissolved in one litre (one dm³) of distilled/deionised water.

Question 2

Each candidate should be provided with:

hazard	materials and apparatus	quantity per candidate
	test-tubes (approximately 125 mm × 16 mm) and a means to support them	2
	5% starch solution in a container labelled solution T supplied with a dropper	5 cm ³
[C]	access to biuret solution labelled biuret solution supplied with a dropper	
[MH][N]	access to iodine solution labelled iodine solution supplied with a dropper	

Question 3

Each candidate should be provided with:

hazard	materials and apparatus	quantity per candidate
[F]	0.1 g of magnesium powder mixed with 0.9 g of copper powder labelled mixture of magnesium and copper (see notes 4 and 6)	1 g
	2.0 mol dm ⁻³ hydrochloric acid labelled dilute hydrochloric acid	75 cm ³
	conical flask (see note 1)	1
	delivery tube with a bung (see note 1)	1
	clamp stand, boss and clamp (see note 1)	1
	100 cm ³ measuring cylinder in assembled apparatus (see note 1)	1
	large container for water (see note 1)	1
	50 cm ³ measuring cylinder	1
	filter papers	2
	conical flask (see note 2)	1
	filter funnel (see note 2)	1
	piece of plastic film (see note 5)	1
	access to top pan balance measuring to at least 2 decimal places (see note 3)	
	paper towels	3
	access to water for rinsing a flask	

Notes

- The apparatus should be assembled as shown in Fig. 3.1.

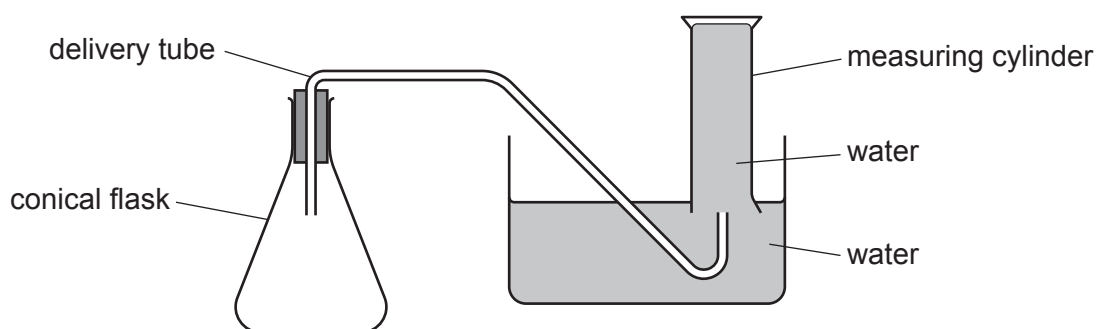

Fig. 3.1

The delivery tube should be made of flexible plastic or rubber tubing.

The apparatus will be more stable if the conical flask is clamped.

- The filter funnel should be placed into the top of the conical flask. An excess of 50 cm³ of liquid will be filtered.

6

3. Candidates will need to make 4 mass readings in total.
4. When the 1 g sample is added to 50 cm³ 2.0 mol dm⁻³ hydrochloric acid, the gas given off should be between 50 cm³ and 100 cm³. The amount of magnesium may be altered to achieve this and the overall mass of the mixture should still be 1 g.
5. A wet filter paper will be placed on the plastic film in order that the filter paper can be placed onto the balance.
6. The mixture should be made for the whole cohort and then 1 g given to each candidate. The mixture needs to be as homogeneous as possible.

Question 4

No apparatus or materials are required for Question 4.

Question 5

Each candidate should be provided with:

hazard	materials and apparatus	quantity per candidate
	metre rule with a millimetre scale (see note 1)	1
	30 cm ruler with a millimetre scale	1
	triangular block to act as a pivot for the metre rule (see note 2)	1
	piece of modelling clay (e.g., Plasticine, Newplast) of mass approximately 30 g (see note 3)	1
	access to a balance capable of measuring mass to 0.1 g (see note 4)	
	100 cm ³ measuring cylinder	1
	250 cm ³ beaker containing approximately 100 cm ³ of cold water labelled water	1
	piece of thread long enough for candidates to be able to lower the modelling clay into the measuring cylinder	1
	paper towels	3

Notes

1. Check that the metre rule balances on the pivot when the 50.0 cm mark is approximately at the pivot.
2. A prism or a wooden block is suitable.
3. The modelling clay should be pre-worked so that it is easy for the candidate to mould. Mould the modelling clay into an approximately spherical shape.
4. It is **not** necessary to provide a balance for each set of apparatus, but candidates must have convenient access to a balance.

Action at changeover

Remove the modelling clay from the measuring cylinder and dry the clay.

Remove the thread from the modelling clay.

Empty the measuring cylinder.

Re-fill the beaker with cold water.

Re-mould the modelling clay into an approximate spherical shape.

Place the pivot, metre rule, thread and modelling clay on the bench.

Question 6

Each candidate should be provided with:

hazard	materials and apparatus	quantity per candidate
	250 cm ³ glass beaker (see note 1)	1
	supply of hot water (see notes 2 and 3)	
	thermometer –10 °C to 110 °C graduated in 1 °C intervals (see note 4)	1
	stop-clock	1
	clamp, boss and stand (see note 4)	1
	paper towels	3

Notes

1. If the beaker is not graduated, a line must be drawn on the side of the beaker to indicate a volume of 200 cm³.
2. Each candidate will require 200 cm³ of hot water. The hot water should be supplied and maintained at a temperature of approximately 80 °C and supplied by the supervisor.
3. Candidates should be warned of the dangers of burns or scalds when using very hot water.
4. The thermometer is to be held vertically using the clamp, boss and stand and set up by the supervisor, as shown in Fig. 6.1. Ensure that the clamp does not obscure the temperature scale of the thermometer. The bottom of the thermometer bulb must be above the level of the top of the beaker.

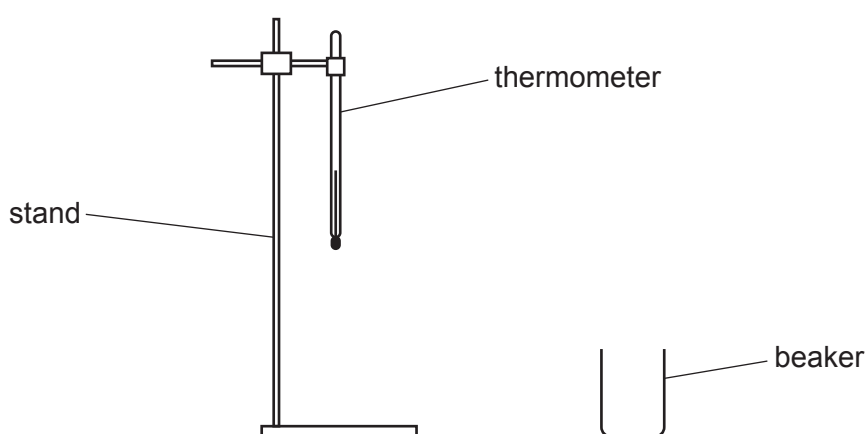

Fig. 6.1

Action at changeover

Remove the thermometer and empty the water from the beaker. Assemble the apparatus as shown in Fig. 6.1.

BLANK PAGE

Permission to reproduce items where third-party owned material protected by copyright is included has been sought and cleared where possible. Every reasonable effort has been made by the publisher (UCLES) to trace copyright holders, but if any items requiring clearance have unwittingly been included, the publisher will be pleased to make amends at the earliest possible opportunity.

To avoid the issue of disclosure of answer-related information to candidates, all copyright acknowledgements are reproduced online in the Cambridge Assessment International Education Copyright Acknowledgements Booklet. This is produced for each series of examinations and is freely available to download at www.cambridgeinternational.org after the live examination series.

Cambridge Assessment International Education is part of Cambridge Assessment. Cambridge Assessment is the brand name of the University of Cambridge Local Examinations Syndicate (UCLES), which is a department of the University of Cambridge.

Supervisor's report

Syllabus and component number

				/		
--	--	--	--	---	--	--

Centre number

--	--	--	--	--

Centre name

Time of the practical session

Laboratory name/number

Give details of any difficulties experienced by the centre or by candidates (include the relevant candidate names and candidate numbers).

You must include:

- any difficulties experienced by the centre in the preparation of materials
- any difficulties experienced by candidates, e.g. due to faulty materials or apparatus
- any specific assistance given to candidates.

Declaration

- 1 Each packet that I am returning to Cambridge International contains all of the following items:
 - the scripts of the candidates specified on the bar code label provided
 - the supervisor’s results relevant to these candidates
 - the supervisor’s reports relevant to these candidates
 - seating plans for each practical session, referring to each candidate by candidate number
 - the attendance register.
- 2 Where the practical exam has taken place in more than one practical session, I have clearly labelled the supervisor’s results, supervisor’s reports and seating plans with the time and laboratory name/number for each practical session.
- 3 I have included details of difficulties relating to each practical session experienced by the centre or by candidates.
- 4 I have reported any other adverse circumstances affecting candidates, e.g. illness, bereavement or temporary injury, directly to Cambridge International on a *special consideration form*.

Signed (supervisor)

Name (in block capitals)