



Cambridge IGCSE™

CO-ORDINATED SCIENCES

0654/53

Paper 5 Practical Test

May/June 2024

CONFIDENTIAL INSTRUCTIONS

This document gives details of how to prepare for and administer the practical exam.

The information in this document and the identity of any materials supplied by Cambridge International are confidential and must NOT reach candidates either directly or indirectly.

The supervisor must complete the report at the end of this document and return it with the scripts.

INSTRUCTIONS

- If you have any queries regarding these confidential instructions, contact Cambridge International stating the centre number, the syllabus and component number and the nature of the query.
email info@cambridgeinternational.org
phone +44 1223 553554

This document has **12** pages. Any blank pages are indicated.



General information about practical exams

Centres must follow the guidance on science practical exams given in the *Cambridge Handbook*.

Safety

Supervisors must follow national and local regulations relating to safety and first aid.

Only those procedures described in the question paper should be attempted.

Supervisors must inform candidates that materials and apparatus used in the exam should be treated with caution. Suitable eye protection should be used where necessary.

The following hazard codes are used in these confidential instructions, where relevant:

C	corrosive	MH	moderate hazard
HH	health hazard	T	acutely toxic
F	flammable	O	oxidising
N	hazardous to the aquatic environment		

Hazard data sheets relating to substances used in this exam should be available from your chemical supplier.

Before the exam

- The packets containing the question papers must **not** be opened before the exam.
- It is assumed that standard school laboratory facilities, as indicated in the *Guide to Planning Practical Science*, will be available.
- Spare materials and apparatus for the tasks set must be available for candidates, if required.

During the exam

- It must be made clear to candidates at the start of the exam that they may request spare materials and apparatus for the tasks set.
- Where specified, the supervisor **must** perform the experiments and record the results as instructed. This must be done **out of sight** of the candidates, using the same materials and apparatus as the candidates.
- Any assistance provided to candidates must be recorded in the supervisor's report.
- If any materials or apparatus need to be replaced, for example, in the event of breakage or loss, this must be recorded in the supervisor's report.

After the exam

- The supervisor must complete a report for each practical session held and each laboratory used.
- Each packet of scripts returned to Cambridge International must contain the following items:
 - the scripts of the candidates specified on the bar code label provided
 - the supervisor's results relevant to these candidates
 - the supervisor's reports relevant to these candidates
 - seating plans for each practical session, referring to each candidate by candidate number
 - the attendance register.

Specific information for this practical exam

During the exam, the supervisor (**not** the invigilator) must do the experiments in Questions 1, 3, 4, 5 and 6 and record the results on a spare copy of the question paper, clearly labelled 'supervisor's results'.

Question 1

Each candidate should be provided with:

hazard	materials and apparatus	quantity per candidate
	approximately 12 cm of dialysis (Visking) tubing of about 14 mm diameter, securely tied at one end with a knot and supplied in tap water (see note 1)	2
	5 cm ³ syringe without needle	1
	100 cm ³ beaker half-filled with 1% starch solution labelled warm starch solution (see notes 2 and 3)	1
	100 cm ³ beaker half-filled with 1% starch solution labelled cold starch solution (see notes 2 and 4)	1
[MH] [N]	20 cm ³ iodine solution in a container accessible with the syringe, labelled iodine solution (see note 5)	1
	stop-clock	1
	access to water for rinsing	
	paper towels	2

Notes

1. Prior to the start of the examination, candidates should be shown how to tie a knot in the open end of the tubing. Candidates can be assisted with this if required.
2. To prepare this solution, dissolve 1 g of soluble starch powder per 100 cm³ of water. To facilitate dissolving, warm water and a stirrer may be used. The solution should then be allowed to cool.
3. The beaker of starch must be supplied in an individual hot water-bath (e.g. a part filled larger beaker or dish that will hold the beaker of starch without the latter falling over) at about 45 °C.
4. The beaker of starch must be supplied in an individual iced water-bath (e.g. a part filled larger beaker or dish that will hold the beaker of starch without the latter falling over).
5. The iodine solution must be concentrated enough to indicate the presence of 1% starch. Candidates will be handling materials with iodine solution with a risk of staining to the skin. Gloves may be provided if the centre feels that candidates will need to wear them.

Question 2

No apparatus or materials are required for Question 2.

Question 3

Each candidate should be provided with:

hazard	materials and apparatus	quantity per candidate
	2.3 mol dm ⁻³ hydrochloric acid labelled dilute hydrochloric acid	50 cm ³
[C]	2.0 mol dm ⁻³ sodium hydroxide labelled aqueous sodium hydroxide	60 cm ³
	25 cm ³ measuring cylinder	1
	10 cm ³ measuring cylinder	1
	polystyrene cup large enough to hold 100 cm ³ of liquid	1
	beaker to hold the polystyrene cup	1
	thermometer –10 °C to +110 °C with 1 °C graduations suitable for stirring	1
	paper towels	3

Question 4

Each candidate should be provided with:

hazard	materials and apparatus	quantity per candidate
[MH][N]	1.0 mol dm ⁻³ copper(II) chloride solution labelled H	20 cm ³
	0.5 mol dm ⁻³ ammonia solution labelled aqueous ammonia	10 cm ³
[MH]	0.4 mol dm ⁻³ sodium hydroxide labelled aqueous sodium hydroxide	10 cm ³
[C]	access to 1.0 mol dm ⁻³ nitric acid labelled dilute nitric acid (see note 1)	
	access to 0.1 mol dm ⁻³ barium nitrate labelled aqueous barium nitrate supplied in a bottle with a dropper or with a separate dropping pipette (see note 1)	
	access to 0.05 mol dm ⁻³ silver nitrate labelled aqueous silver nitrate supplied in a dark bottle with a dropper (see note 1)	
	test-tubes (approximately 125 mm × 16 mm)	5
	means to support test-tubes	1
	wooden splints	2
	Bunsen burner and a means to light it	1
	laboratory mat	1
	paper towels	3
	dropping pipettes	2

Notes

- Each candidate will need to use approximately 3 cm³ of dilute nitric acid, 1 cm³ of aqueous barium nitrate and a few drops of aqueous silver nitrate. If these reagents are shared, no more than 4 candidates should share each sample.

Question 5

Each candidate should be provided with:

hazard	materials and apparatus	quantity per candidate
	bosses, clamps and stands (see note 1)	2
	metre rule with a millimetre scale (see note 2)	1
	steel spring (see note 3)	1
	set-square	1
	loads of 1.0N, 2.0N, 3.0N, 4.0N and 5.0N (see note 4)	1 set

Notes

- The apparatus is to be set up for candidates as shown in Fig. 5.1. The spring must be sufficiently high above the bench so that when the 5.0N load is suspended from the spring, the bottom of the load is above the surface of the bench.

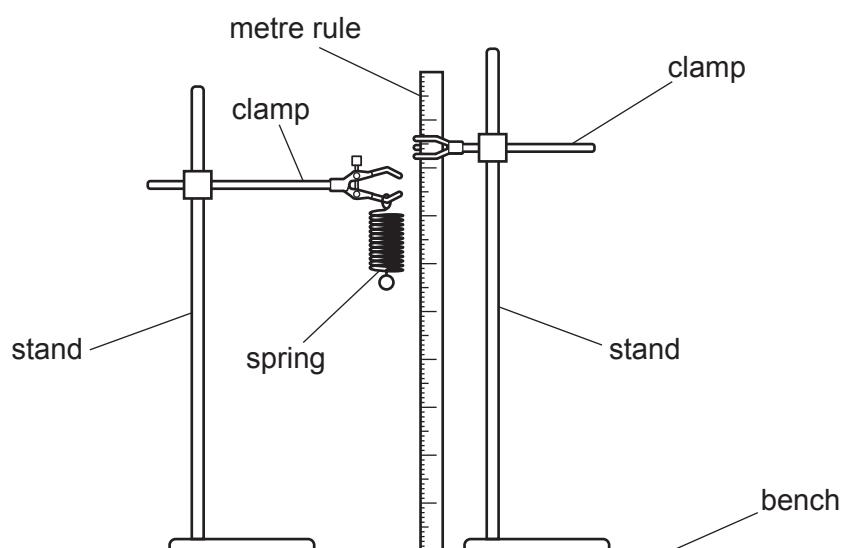

Fig. 5.1

- The metre rule is to be set up for candidates vertically in a clamp close to, and parallel to, the spring, with the 100 cm end touching the bench. A horizontal-read ruler is recommended.
- An expendable steel spring is suitable, for example a 55 mm long spring of diameter 15 mm and spring constant approximately 25 Nm^{-1} (see www.philipharris.co.uk). The spring must be capable of supporting a load of at least 5.0N without overstretching.
- Four 100g slotted masses, each labelled 1.0N, together with a 100g mass hanger labelled 1.0N, are ideal. If slotted masses are not available, a light hook must be provided so that the masses can be suspended from the spring.

Action at changeover

Restore the apparatus to the set-up shown in Fig. 5.1.

Question 6

Each candidate should be provided with:

hazard	materials and apparatus	quantity per candidate
	power source of approximately 2V to 3V (see notes 2 and 3)	1
	filament lamps 2.5V, 0.3A, or similar, in suitable holders (e.g. see www.philipharris.co.uk item B8A56728)	2
	switch – this may be an integral part of the power supply	1
	sufficient connecting leads to set up the circuit shown in Fig. 6.1	
	extra connecting lead	1
	ammeter capable of measuring currents up to 1.00A with a minimum precision of 0.05A	1
	voltmeter capable of measuring up to 3.0V with a minimum precision of 0.1V	1

Notes

- The circuit is to be set up for candidates as shown in Fig. 6.1. Points **X** and **Y** must be labelled.

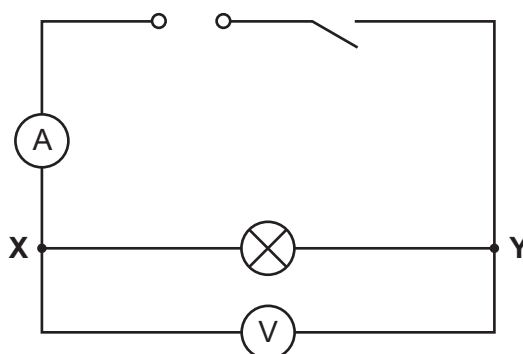

Fig. 6.1

- If candidates are supplied with a variable power source, the voltage should be set by the supervisor and fixed, e.g. taped.
- If dry cells are used as the power source, they must remain adequately charged throughout the examination.
- Spare lamps and leads should be available.
- Candidates will be instructed to rearrange the above circuit. One extra connecting lead will be needed.
- Candidates will be required to rearrange and reconnect the given circuit unaided. If help is required, it may be given, but the candidate number must be noted on the supervisor's report.

Action at changeover

Reconnect the circuit as shown in Fig. 6.1.

BLANK PAGE

BLANK PAGE

Permission to reproduce items where third-party owned material protected by copyright is included has been sought and cleared where possible. Every reasonable effort has been made by the publisher (UCLES) to trace copyright holders, but if any items requiring clearance have unwittingly been included, the publisher will be pleased to make amends at the earliest possible opportunity.

To avoid the issue of disclosure of answer-related information to candidates, all copyright acknowledgements are reproduced online in the Cambridge Assessment International Education Copyright Acknowledgements Booklet. This is produced for each series of examinations and is freely available to download at www.cambridgeinternational.org after the live examination series.

Cambridge Assessment International Education is part of Cambridge Assessment. Cambridge Assessment is the brand name of the University of Cambridge Local Examinations Syndicate (UCLES), which is a department of the University of Cambridge.

Supervisor's report

Syllabus and component number

				/		
--	--	--	--	---	--	--

Centre number

--	--	--	--	--

Centre name

Time of the practical session

Laboratory name/number

Give details of any difficulties experienced by the centre or by candidates (include the relevant candidate names and candidate numbers).

You must include:

- any difficulties experienced by the centre in the preparation of materials
- any difficulties experienced by candidates, e.g. due to faulty materials or apparatus
- any specific assistance given to candidates.

Declaration

- 1 Each packet that I am returning to Cambridge International contains all of the following items:
 - the scripts of the candidates specified on the bar code label provided
 - the supervisor’s results relevant to these candidates
 - the supervisor’s reports relevant to these candidates
 - seating plans for each practical session, referring to each candidate by candidate number
 - the attendance register.
- 2 Where the practical exam has taken place in more than one practical session, I have clearly labelled the supervisor’s results, supervisor’s reports and seating plans with the time and laboratory name/number for each practical session.
- 3 I have included details of difficulties relating to each practical session experienced by the centre or by candidates.
- 4 I have reported any other adverse circumstances affecting candidates, e.g. illness, bereavement or temporary injury, directly to Cambridge International on a *special consideration form*.

Signed (supervisor)

Name (in block capitals)