

Topical
REVISION
NOTES

ADDITIONAL
MATHEMATICS

LEVEL



- ✓ Comprehensive Revision Notes
- ✓ Effective Study Guide

PREFACE

O Level Additional Mathematics Topical Revision Notes has been written in accordance with the latest syllabus issued by the Ministry of Education, Singapore.

This book is divided into 16 units, each covering a topic as laid out in the syllabus. Important concepts and formulae are highlighted in each unit, with relevant worked examples to help students learn how to apply theoretical knowledge to examination questions.

To make this book suitable for N(A) Level students, sections not applicable for the N(A) Level examination are indicated with a bar (■).

We believe this book will be of great help to teachers teaching the subject and students preparing for their O Level and N(A) Level Additional Mathematics examinations.

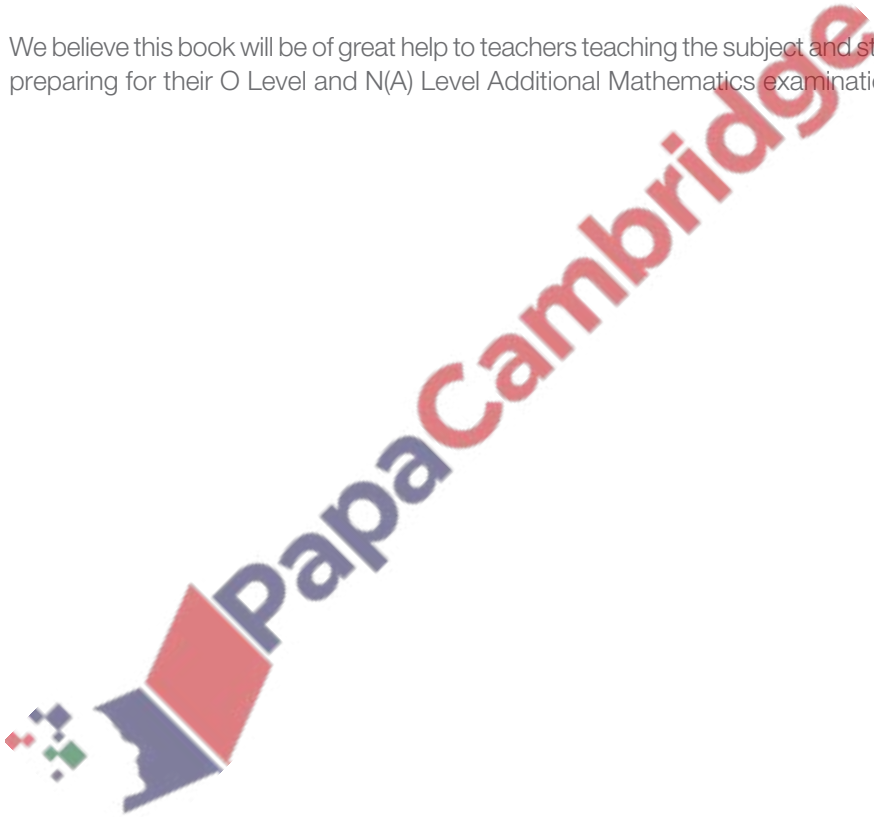

CONTENTS

Unit 1	Simultaneous Equations, Polynomials and Partial Fractions	1
Unit 2	Quadratic Equations, Inequalities and Modulus Functions	25
Unit 3	Binomial Theorem	44
Unit 4	Indices, Surds and Logarithms	52
Unit 5	Coordinate Geometry	67
Unit 6	Further Coordinate Geometry	77
Unit 7	Linear Law	85
Unit 8	Trigonometric Functions and Equations	93
Unit 9	Trigonometric Identities and Formulae	104
Unit 10	Proofs in Plane Geometry	113
Unit 11	Differentiation and its Applications	121
Unit 12	Further Applications of Differentiation	129
Unit 13	Differentiation of Trigonometric, Logarithmic & Exponential Functions and their Applications	139
Unit 14	Integration	148
Unit 15	Applications of Integration	158
Unit 16	Kinematics	170
	Mathematical Formulae	178

UNIT 1

Simultaneous Equations, Polynomials and Partial Fractions

Simultaneous Linear Equations

1. The solution(s) of a pair of linear and/or non-linear equations correspond to the coordinates of the intersection point(s) of the graphs.
2. A pair of simultaneous linear equations is of the form
$$ax + by = p$$
$$cx + dy = q,$$
where
 a, b, c and d are constants,
 x and y are variables to be determined.
3. There is usually one solution to a pair of simultaneous linear equations.
4. Methods of solving simultaneous linear equations:
 - Elimination (covered in 'O' level Mathematics)
 - Substitution (covered in 'O' level Mathematics)
 - Matrix method (not in syllabus)
 - Graphical method (covered in 'O' level Mathematics)



5. The methods most commonly used to solve simultaneous linear equations are

- **Elimination**

The coefficient of one of the variables is made the same in both equations. The equations are then either added or subtracted to form a single linear equation with only one variable.

Example 1

Solve the simultaneous equations

$$\begin{aligned}2x + 3y &= 15 \\ -3y + 4x &= 3\end{aligned}$$

Solution

$$\begin{aligned}2x + 3y &= 15 \quad \text{--- (1)} \\ -3y + 4x &= 3 \quad \text{--- (2)}\end{aligned}$$

(1) + (2):

$$\begin{aligned}(2x + 3y) + (-3y + 4x) &= 18 \\ 6x &= 18 \\ x &= 3\end{aligned}$$

When $x = 3$, $y = 3$.

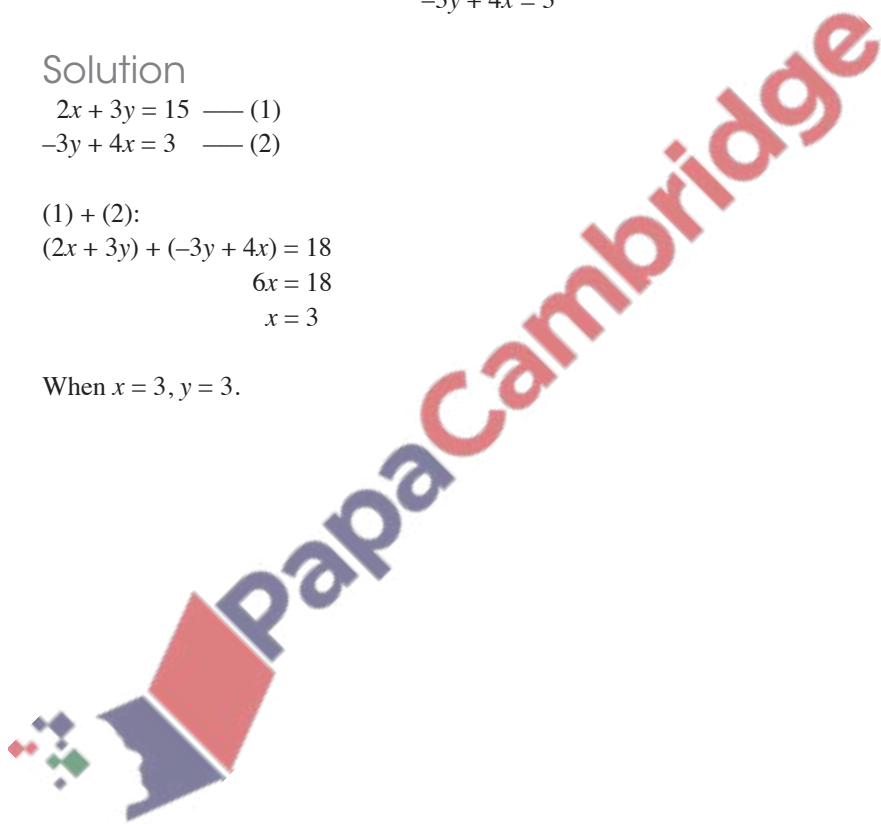

- **Substitution**

A variable is made the subject of the chosen equation. This equation is then substituted into the equation that was not chosen to solve for the variable.

Example 2

Solve the simultaneous equations

$$\begin{aligned}2x - 3y &= -2, \\ y + 4x &= 24.\end{aligned}$$

Solution

$$2x - 3y = -2 \quad \text{--- (1)}$$

$$y + 4x = 24 \quad \text{--- (2)}$$

From (1):

$$x = \frac{-2 + 3y}{2}$$

$$x = -1 + \frac{3}{2}y \quad \text{--- (3)}$$

Substitute (3) into (2):

$$y + 4\left(-1 + \frac{3}{2}y\right) = 24$$

$$y - 4 + 6y = 24$$

$$7y = 28$$

$$y = 4$$

When $y = 4$, $x = 5$.

Simultaneous Non-Linear Equations

6. A non-linear equation is **not** of the form $ax + by = p$.
7. Methods of solving simultaneous non-linear equations:
 - Substitution
 - Graphical method (covered in 'O' level Mathematics)

8. The method most commonly used to solve simultaneous non-linear equations is
- Substitution
9. The substitution method:
- Step 1:** Use the linear equation to express one of the variables in terms of the other.
- Step 2:** Substitute it into the non-linear equation.
- Step 3:** Substitute the value(s) obtained in Step 2 into the linear equation to obtain the value of the other variable.

Example 3

Solve the following pair of simultaneous equations.

$$\begin{aligned} 3y &= x + 3 \\ y^2 &= 13 + 2x \end{aligned}$$

Solution

$$3y = x + 3 \quad \text{--- (1)}$$

$$y^2 = 13 + 2x \quad \text{--- (2)}$$

From (1):

$$y = \frac{1}{3}x + 1 \quad \text{--- (3)} \quad (\text{Use the linear equation to express } y \text{ in terms of } x.)$$

Substitute (3) into (2):

$$\left(\frac{1}{3}x + 1\right)^2 = 13 + 2x$$

$$\frac{1}{9}x^2 + \frac{2}{3}x + 1 = 13 + 2x$$

$$\frac{1}{9}x^2 - \frac{4}{3}x - 12 = 0$$

$$x^2 - 12x - 108 = 0$$

$$(x - 18)(x + 6) = 0$$

$$x = 18 \text{ or } x = -6$$

When $x = 18$, $y = 7$. (Substitute the values of x into the linear equation to obtain

When $x = -6$, $y = -1$. the corresponding values of y .)

$$\therefore x = 18, y = 7 \quad \text{or} \quad x = -6, y = -1$$

Example 4

Solve the simultaneous equations

$$\begin{aligned}x^2 - 2y^2 &= -17, \\ x - y &= -4.\end{aligned}$$

Solution

$$x^2 - 2y^2 = -17 \quad \text{--- (1)}$$

$$x - y = -4 \quad \text{--- (2)}$$

From (2),

$$y = x + 4 \quad \text{--- (3)} \quad (\text{Use the linear equation to express } y \text{ in terms of } x.)$$

Substitute (3) into (1):

$$x^2 - 2(x + 4)^2 = -17 \quad (\text{Substitute the linear equation into the non-linear equation.})$$

$$x^2 - 2x^2 - 16x - 32 = -17$$

$$-x^2 - 16x - 15 = 0$$

$$x^2 + 16x + 15 = 0$$

$$(x + 1)(x + 15) = 0 \quad (\text{Factorise the quadratic expression.})$$

$$x = -1 \text{ or } x = -15$$

When $x = -1$, $y = 3$. (Substitute the values of x into the linear equation

When $x = -15$, $y = -11$. to obtain the corresponding values of y .)

$$\therefore x = -1, y = 3 \text{ or } x = -15, y = -11$$



Example 5

The line $2x + y = 5$ meets the curve $x^2 + y^2 + x + 12y - 29 = 0$ at the points A and B . Find the coordinates of A and B .

Solution

$$2x + y = 5 \quad \text{--- (1)}$$

$$x^2 + y^2 + x + 12y - 29 = 0 \quad \text{--- (2)}$$

From (1),

$$y = 5 - 2x \quad \text{--- (3)} \quad \text{(Use the linear equation to express } y \text{ in terms of } x \text{.)}$$

Substitute (3) into (2):

$$x^2 + (5 - 2x)^2 + x + 12(5 - 2x) - 29 = 0 \quad \text{(Substitute the linear equation into the non-linear equation.)}$$

$$x^2 + 25 - 20x + 4x^2 + x + 60 - 24x - 29 = 0$$

$$5x^2 - 43x + 56 = 0$$

$$(5x - 8)(x - 7) = 0 \quad \text{(Factorise the quadratic expression.)}$$

$$x = 1\frac{3}{5} \text{ or } x = 7$$

When $x = 1\frac{3}{5}$, $y = 1\frac{4}{5}$. (Substitute the values of x into the linear equation to obtain the corresponding values of y .)

When $x = 7$, $y = -9$.

\therefore The coordinates of A and B are $\left(1\frac{3}{5}, 1\frac{4}{5}\right)$ and $(7, -9)$.

Definitions

- 10.** A polynomial in x is a mathematical expression of a sum of terms, each of the form ax^n , where a is a constant and n is a non-negative integer. It is usually denoted as $f(x)$.
i.e. $f(x) = a_n x^n + a_{n-1} x^{n-1} + a_{n-2} x^{n-2} + \dots + a_2 x^2 + a_1 x + a_0$
- 11.** Examples of polynomials include $x^3 + 2x - 1$, $6x^4 - \frac{1}{2}x^2$ and $-0.2x + x^2 + 5x^3$.
Examples of non-polynomials include $2x^2 + \frac{1}{x}$, $4 - \sqrt{x}$ and $x + x^{\frac{2}{3}}$.
- 12.** a_n, a_{n-1}, \dots, a_0 are coefficients.
 a_0 is also called the constant term.
- 13.** The degree (or order) of a polynomial in x is given by the highest power of x .
For example, the degree of $6x^3 - 2x^2 + x - 8$ is 3 and the degree of $1 - x + 5x^4$ is 4.
- 14.** The value of $f(x)$ at $x = c$ is $f(c)$.
For example, if $f(x) = 2x^3 + x^2 - x - 4$, then the value of $f(x)$ at $x = 1$ is
 $f(1) = 2(1)^3 + 1^2 - 1 - 4 = -2$.

Identities

- 15.** An identity is an equation in which the expression on the LHS (left-hand side) is equal to the expression on the RHS (right-hand side).
- 16.** Methods of finding the unknown constants in an identity:
- By substitution of special values of x
 - By comparing coefficients



Example 6

It is given that for all values of x , $2x^3 + 5x^2 - x - 2 = (Ax + 3)(x + B)(x - 1) + C$.
Find the values of A , B and C .

Solution

$$\begin{aligned} \text{Let } x = 1: 2(1)^3 + 5(1)^2 - 1 - 2 &= (A + 3)(1 + B)(1 - 1) + C && \text{(Letting } x \text{ be 1 leaves us with 1 unknown, } C.) \\ C &= 4 \end{aligned}$$

$$\begin{aligned} \text{Let } x = 0: 2(0)^3 + 5(0)^2 - 0 - 2 &= (0 + 3)(0 + B)(0 - 1) + 4 && \text{(Letting } x \text{ be 0 leaves us with 1 unknown, } B.) \\ B &= 2 \end{aligned}$$

$$\begin{aligned} \text{Comparing coefficients of } x^3, \\ A &= 2 \end{aligned}$$

$$\therefore A = 2, B = 2 \text{ and } C = 4$$

Example 7

Given that $2x^3 + 3x^2 - 14x - 5 = (2x - 3)(x + 3)Q(x) + ax + b$, where $Q(x)$ is a polynomial, find the value of a and of b .

Solution

$$\begin{aligned} \text{Let } x = -3: 2(-3)^3 + 3(-3)^2 - 14(-3) - 5 &= -3a + b \\ 10 &= -3a + b \\ 3a - b &= -10 \quad \text{--- (1)} \end{aligned}$$

$$\begin{aligned} \text{Let } x = \frac{3}{2}: 2\left(\frac{3}{2}\right)^3 + 3\left(\frac{3}{2}\right)^2 - 14\left(\frac{3}{2}\right) - 5 &= \frac{3}{2}a + b \\ -\frac{25}{2} &= \frac{3}{2}a + b \\ 3a + 2b &= -25 \quad \text{--- (2)} \end{aligned}$$

$$\begin{aligned} (2) - (1): 3b &= -15 \\ b &= -5 \\ a &= -5 \\ \therefore a = -5, b = -5 \end{aligned}$$

Long Division

17. When $3x^3 + 4x^2 - 6x + 3$ is divided by $x - 1$,
- the dividend is $3x^3 + 4x^2 - 6x + 3$
 - the quotient is $3x^2 + 7x + 1$
 - the divisor is $x - 1$
 - the remainder is 4.

$$\begin{array}{r}
 \phantom{\text{Divisor}} \rightarrow x-1 \overline{) 3x^3 + 4x^2 - 6x + 3} \quad \leftarrow \text{Dividend} \\
 \underline{-(3x^3 - 3x^2)} \\
 7x^2 - 6x + 3 \\
 \underline{-(7x^2 - 7x)} \\
 x + 3 \\
 \underline{-(x - 1)} \\
 4 \quad \leftarrow \text{Remainder}
 \end{array}$$

$3x^2 + 7x + 1$ ← Quotient

18. Dividend = Quotient \times Divisor + Remainder
19. The order of the remainder is always at least one degree less than that of the divisor.
20. The process of long division is stopped when the degree of the remainder is less than the degree of the divisor.

Synthetic Method

21. The synthetic method can be used to divide a polynomial by a linear divisor.

To divide $3x^3 + 4x^2 - 6x + 3$ by $x - 1$,

$$\begin{array}{r|rrrr}
 1 & 3 & 4 & -6 & 3 \\
 & & 3 & 7 & 1 \\
 \hline
 & 3 & 7 & 1 & 4
 \end{array}$$

← Coefficients of the Dividend

Coefficients of the Quotient ↑
Remainder

Remainder Theorem

22. The Remainder Theorem states that when a polynomial $f(x)$ is divided by $ax - b$, the remainder is $f\left(\frac{b}{a}\right)$.
23. If $f(x)$ is divided by a quadratic divisor, then the remainder is a linear function or a constant.

Example 8

Find the remainder when $x^3 - 2x^2 + 3x - 1$ is divided by $x - 1$.

Solution

Let $f(x) = x^3 - 2x^2 + 3x - 1$.

By Remainder Theorem,

$$\begin{aligned}\text{The remainder is } f(1) &= (1)^3 - 2(1)^2 + 3(1) - 1 \\ &= 1 - 2 + 3 - 1 \\ &= 1\end{aligned}$$

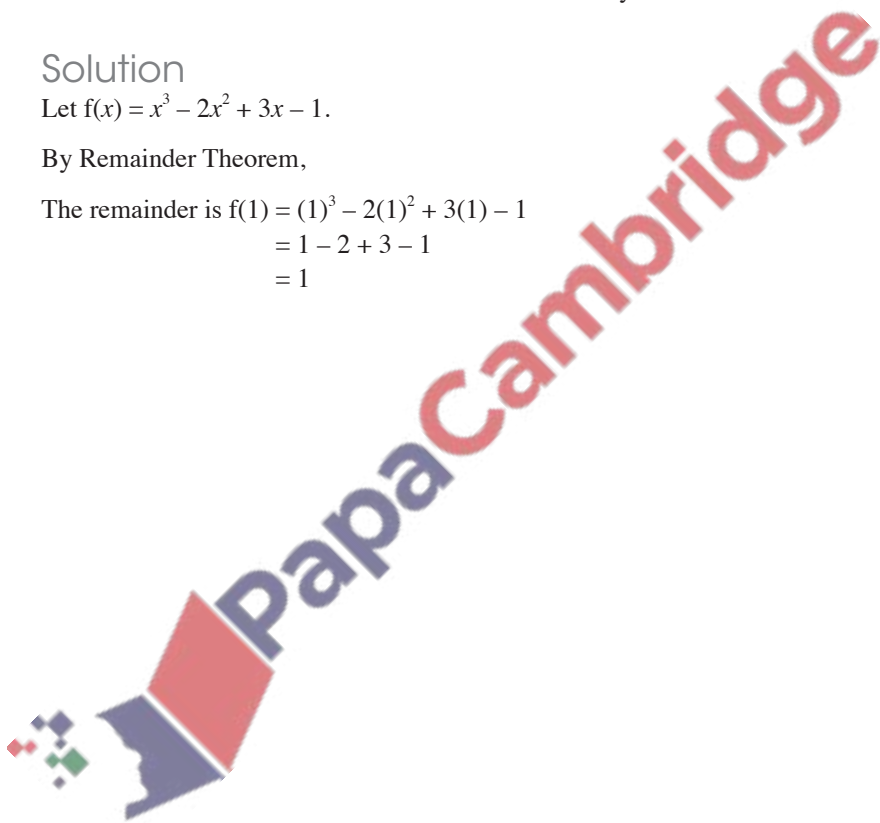

Example 9

Given that $f(x) = ax^3 - 8x^2 - 9x + b$ is exactly divisible by $3x - 2$ and leaves a remainder of 6 when divided by x , find the value of a and of b .

Solution

Since $f\left(\frac{2}{3}\right) = 0$,

$$a\left(\frac{2}{3}\right)^3 - 8\left(\frac{2}{3}\right)^2 - 9\left(\frac{2}{3}\right) + b = 0$$

$$\frac{8}{27}a - \frac{32}{9} - 6 + b = 0$$

$$8a - 96 - 162 + 27b = 0$$

$$8a + 27b = 258 \quad \text{--- (1)}$$

Since $f(0) = 6$,

$$a(0)^3 - 8(0)^2 - 9(0) + b = 6$$

$$b = 6 \quad \text{--- (2)}$$

Substitute $b = 6$ into (1):

$$8a + 27(6) = 258$$

$$a = 12$$

$$\therefore a = 12, b = 6$$

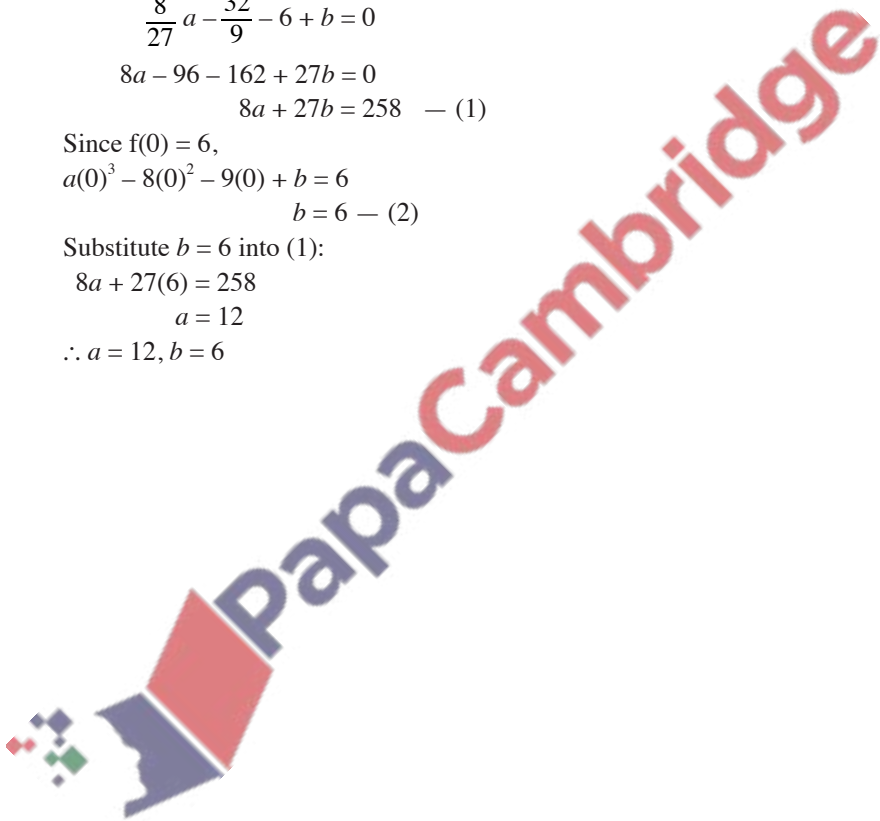

Example 10

Given that $f(x) = 6x^3 + 7x^2 - x + 3$, find the remainder when $f(x)$ is divided by $x + 1$.

Solution

Method 1: Long division

$$\begin{array}{r} 6x^2 + x - 2 \\ x + 1 \overline{) 6x^3 + 7x^2 - x + 3} \\ \underline{-(6x^3 + 6x^2)} \\ x^2 - x + 3 \\ \underline{-(x^2 + x)} \\ -2x + 3 \\ \underline{-(-2x - 2)} \\ 5 \end{array}$$

\therefore The remainder is 5.

Method 2: Synthetic method

$$\begin{array}{r|rrrr} -1 & 6 & 7 & -1 & 3 \\ & & -6 & -1 & 2 \\ \hline & 6 & 1 & -2 & 5 \end{array}$$

\therefore The remainder is 5.

Method 3: Remainder Theorem

$$f(x) = 6x^3 + 7x^2 - x + 3$$

$$\begin{aligned} f(-1) &= 6(-1)^3 + 7(-1)^2 - (-1) + 3 \\ &= 5 \end{aligned}$$

\therefore The remainder is 5.

Factor Theorem

24. The Factor Theorem states that when a polynomial $f(x)$ is divided by $ax - b$ and

that $f\left(\frac{b}{a}\right) = 0$, then $ax - b$ is a factor of $f(x)$.

25. Conversely, if $ax - b$ is a factor of $f(x)$, then $f\left(\frac{b}{a}\right) = 0$ and $f(x)$ is divisible by $ax - b$.

Example 11

Given that $x + 2$ is a factor of $x^3 + ax^2 - x + 4$, calculate the value of a .

Solution

Let $f(x) = x^3 + ax^2 - x + 4$.

Since $x + 2$ is a factor of $f(x)$, by Factor Theorem,

$$\begin{aligned}f(-2) &= 0 \\(-2)^3 + a(-2)^2 - (-2) + 4 &= 0 \\-8 + 4a + 2 + 4 &= 0 \\-2 + 4a &= 0 \\a &= \frac{1}{2}\end{aligned}$$

Example 12

Prove that $x + 2$ is a factor of $4x^3 - 13x + 6$. Hence solve the equation $4x^3 - 13x + 6 = 0$.

Solution

Let $f(x) = 4x^3 - 13x + 6$. (To prove that $x + 2$ is a factor of $f(x)$,

$$\begin{aligned}f(-2) &= 4(-2)^3 - 13(-2) + 6 \\&= 0\end{aligned}$$

we need to show that $f(-2) = 0$.)

$\therefore x + 2$ is a factor of $4x^3 - 13x + 6$.

Now $f(x) = 4x^3 - 13x + 6 = (x + 2)(4x^2 + kx + 3)$, where k is a constant.

Comparing coefficients of x^2 ,

$$0 = 8 + k$$

$$k = -8$$

$$\text{i.e. } f(x) = (x + 2)(4x^2 - 8x + 3)$$

$$= (x + 2)(2x - 1)(2x - 3)$$

To solve $4x^3 - 13x + 6 = 0$,

$$(x + 2)(2x - 1)(2x - 3) = 0$$

$$\therefore x = -2 \text{ or } x = \frac{1}{2} \text{ or } x = \frac{3}{2}$$

Example 13

Given that $4x^3 + ax^2 + bx + 2$ is exactly divisible by $x^2 - 3x + 2$, find the value of a and of b . Hence sketch the graph of $y = 4x^3 + ax^2 + bx + 2$ for the values of a and b found.

Solution

$$\text{Let } f(x) = 4x^3 + ax^2 + bx + 2.$$

$$\text{Since } x^2 - 3x + 2 = (x - 1)(x - 2),$$

$f(x)$ is exactly divisible by $(x - 1)(x - 2)$, (Factorise the quadratic divisor.)

$$\text{i.e. } f(1) = 0 \text{ and } f(2) = 0.$$

$$\text{When } f(1) = 0,$$

$$4(1)^3 + a(1)^2 + b(1) + 2 = 0$$

$$4 + a + b + 2 = 0$$

$$a + b = -6 \quad \text{--- (1)}$$

$$\text{When } f(2) = 0,$$

$$4(2)^3 + a(2)^2 + b(2) + 2 = 0$$

$$32 + 4a + 2b + 2 = 0$$

$$4a + 2b = -34$$

$$2a + b = -17 \quad \text{--- (2)}$$

$$(2) - (1):$$

$$a = -11$$

$$b = 5$$

$$\therefore a = -11, b = 5$$

$$f(x) = 4x^3 - 11x^2 + 5x + 2 = (x^2 - 3x + 2)(px + q)$$

Comparing coefficients of x^3 ,

$$p = 4$$

Comparing constants,

$$2 = 2q$$

$$q = 1$$

$$f(x) = (x^2 - 3x + 2)(4x + 1)$$

$$= (x - 1)(x - 2)(4x + 1)$$

$$\text{When } f(x) = 0,$$

$$x = 1 \text{ or } x = 2 \text{ or } x = -\frac{1}{4}. \quad \text{(It is a good practice to find the intercepts with the coordinate axes before sketching the graph.)}$$

When $x = 0$,
 $f(0) = 2$.

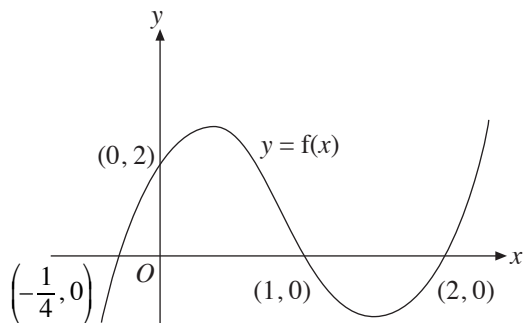

Factorisation of Cubic Expressions

26. A cubic expression is of the form $ax^3 + bx^2 + cx + d$.
27. Cubic expressions are factorised into:
- 3 linear factors, i.e. $(px + q)(rx + s)(tx + u)$, or
 - 1 linear and 1 quadratic factor, i.e. $(px + q)(rx^2 + sx + t)$, where $rx^2 + sx + t$ cannot be factorised into 2 linear factors
28. Methods of factorising cubic expressions:
- Trial and error
 - Long division
 - Synthetic method
 - Comparing coefficients
29. Sum and difference of cubes:
- Sum of cubes: $a^3 + b^3 = (a + b)(a^2 - ab + b^2)$
 - Difference of cubes: $a^3 - b^3 = (a - b)(a^2 + ab + b^2)$

Solving Cubic Equations

30. To solve the equation $f(x) = 0$,

Step 1: Factorise $f(x)$ using the Factor Theorem.

Step 2: Use the synthetic method or compare coefficients to factorise $f(x)$ completely.

Step 3: Equate each factor to zero and use general solution where necessary.

Example 14

Solve the equation $2x^3 + x^2 - 5x + 2 = 0$.

Solution

$$\text{Let } f(x) = 2x^3 + x^2 - 5x + 2.$$

$$f(1) = 2 + 1 - 5 + 2$$

$$= 0$$

$\therefore (x - 1)$ is a factor of $f(x)$.

By long division,

$$\begin{array}{r} 2x^2 + 3x - 2 \\ x - 1 \overline{) 2x^3 + x^2 - 5x + 2} \\ \underline{-(2x^3 - 2x^2)} \\ 3x^2 - 5x + 2 \\ \underline{-(3x^2 - 3x)} \\ -2x + 2 \\ \underline{-(-2x + 2)} \\ 0 \end{array}$$

$$\begin{aligned} f(x) &= (x - 1)(2x^2 + 3x - 2) \\ &= (x - 1)(2x - 1)(x + 2) \end{aligned}$$

When $f(x) = 0$,

$$x = 1 \text{ or } x = \frac{1}{2} \text{ or } x = -2.$$



PapaCambridge

Example 15

In the cubic polynomial $f(x)$, the coefficient of x^3 is 4 and the roots of $f(x) = 0$ are 3, $\frac{1}{2}$ and -4 .

- (i) Express $f(x)$ as a cubic polynomial in x with integer coefficients.
- (ii) Find the remainder when $f(x)$ is divided by $2x - 5$.
- (iii) Solve the equation $f(\sqrt{x}) = 0$.

Solution

- (i) Since the roots of $f(x) = 0$ are 3, $\frac{1}{2}$ and -4 , the factors of $f(x)$ are $x - 3$, $2x - 1$ and $x + 4$.

$$\begin{aligned}\text{Given also that the coefficient of } x^3 \text{ is 4, } f(x) &= 2(x - 3)(2x - 1)(x + 4) \\ &= 4x^3 + 2x^2 - 50x + 24\end{aligned}$$

(ii)
$$\begin{aligned}f\left(\frac{5}{2}\right) &= 4\left(\frac{5}{2}\right)^3 + 2\left(\frac{5}{2}\right)^2 - 50\left(\frac{5}{2}\right) + 24 \\ &= -26\end{aligned}$$

\therefore The remainder is -26 .

- (iii) Since $f(x) = 2(x - 3)(2x - 1)(x + 4)$,
 $f(\sqrt{x}) = 2(\sqrt{x} - 3)(2\sqrt{x} - 1)(\sqrt{x} + 4)$ (Note that x is replaced with \sqrt{x} .)

When $f(\sqrt{x}) = 0$,

$$2(\sqrt{x} - 3)(2\sqrt{x} - 1)(\sqrt{x} + 4) = 0$$

$$\sqrt{x} - 3 = 0 \quad \text{or} \quad 2\sqrt{x} - 1 = 0 \quad \text{or} \quad \sqrt{x} + 4 = 0$$

$$\sqrt{x} = 3 \qquad \qquad \sqrt{x} = \frac{1}{2} \qquad \qquad \sqrt{x} = -4 \quad (\text{no real solution})$$

$$x = 9$$

$$x = \frac{1}{4}$$

$$\therefore x = 9 \text{ or } x = \frac{1}{4}$$

Algebraic Fractions

31. An algebraic fraction is the ratio of two polynomials of the form $\frac{P(x)}{D(x)}$, where $P(x)$ and $D(x)$ are polynomials in x .

Proper and Improper Fractions

32. If the degree of $P(x)$ is less than the degree of $D(x)$, $\frac{P(x)}{D(x)}$ is a proper fraction.

33. If the degree of $P(x)$ is more than or equal to the degree of $D(x)$, $\frac{P(x)}{D(x)}$ is an improper fraction.

34. From an improper algebraic fraction $\frac{P(x)}{D(x)}$, we can make use of long division to obtain $\frac{P(x)}{D(x)} = Q(x) + \frac{R(x)}{D(x)}$, where $Q(x)$ is a polynomial and $\frac{R(x)}{D(x)}$ is a proper algebraic fraction.

35. To express a compound algebraic fraction into partial fractions:

Step 1: Determine if the compound fraction is proper or improper. If it is improper, perform long division (or use the synthetic method if the denominator is linear).

Step 2: Ensure that the denominator is completely factorised.

Step 3: Express the proper fraction in partial fractions according to the cases below.

Step 4: Solve for unknown constants by substituting values of x and/or comparing coefficients of like terms and/or using the “Cover-Up Rule”.

Rules of Partial Fractions

36.

Case	Denominator of fraction	Algebraic fraction	Expression used
1	Linear factors	$\frac{mx + n}{(ax + b)(cx + d)}$	$\frac{A}{ax + b} + \frac{B}{cx + d}$
2	Repeated linear factors	$\frac{mx + n}{(ax + b)(cx + d)^2}$	$\frac{A}{ax + b} + \frac{B}{cx + d} + \frac{C}{(cx + d)^2}$
3	Quadratic factor which cannot be factorised	$\frac{mx + n}{(ax + b)(x^2 + c^2)}$	$\frac{A}{ax + b} + \frac{Bx + C}{x^2 + c^2}$

Example 16

Express $\frac{7-2x}{x^2+x-6}$ in partial fractions.

Solution

First factorise the denominator to get the algebraic fraction in the form

$$\text{of } \frac{mx+n}{(ax+b)(cx+d)}.$$

$$x^2+x-6=(x+3)(x-2)$$

$$\frac{7-2x}{x^2+x-6}=\frac{7-2x}{(x+3)(x-2)}$$

$$\text{Then, let } \frac{7-2x}{(x+3)(x-2)}=\frac{A}{x+3}+\frac{B}{x-2}.$$

Multiply throughout by $(x+3)(x-2)$,

$$7-2x=A(x-2)+B(x+3)$$

Let $x=2$: $7-2(2)=5B$ (Substituting $x=2$ leaves us with 1 unknown, B .)

$$B=\frac{3}{5}$$

Let $x=-3$: $7-2(-3)=A(-5)$ (Substituting $x=-3$ leaves us with 1 unknown, A .)

$$A=-\frac{13}{5}$$

$$\therefore \frac{7-2x}{x^2+x-6}=-\frac{13}{5(x+3)}+\frac{3}{5(x-2)}$$



Example 17

Express $\frac{x^4 + 9}{x^3 + 3x}$ in partial fractions.

Solution

First we need to perform long division on $\frac{x^4 + 9}{x^3 + 3x}$.

$$\begin{array}{r} x \\ x^3 + 3x \overline{) x^4 + 0x^2 + 9} \\ \underline{-(x^4 + 3x^2)} \\ -3x^2 + 9 \end{array}$$

$$\begin{aligned} \frac{x^4 + 9}{x^3 + 3x} &= x + \frac{-3x^2 + 9}{x^3 + 3x} \\ &= x + \frac{-3x^2 + 9}{x(x^2 + 3)} \end{aligned}$$

$$\text{Let } \frac{-3x^2 + 9}{x(x^2 + 3)} = \frac{A}{x} + \frac{Bx + C}{x^2 + 3}.$$

Multiply throughout by $x(x^2 + 3)$,

$$-3x^2 + 9 = A(x^2 + 3) + (Bx + C)x$$

$$\text{Let } x = 0 : 9 = 3A$$

$$A = 3$$

Comparing coefficients of x^2 ,

$$-3 = A + B$$

$$= 3 + B$$

$$B = -6$$

Comparing coefficients of x ,

$$C = 0$$

$$\therefore \frac{x^4 + 9}{x^3 + 3x} = x + \frac{3}{x} - \frac{6x}{x^2 + 3}$$

Example 18

Express $\frac{2x^3 - 2x^2 - 24x - 7}{x^2 - x - 12}$ in partial fractions.

Solution

By long division,

$$\begin{array}{r} 2x \\ x^2 - x - 12 \overline{) 2x^3 - 2x^2 - 24x - 7} \\ \underline{-(2x^3 - 2x^2 - 24x)} \\ -7 \end{array}$$

$$\begin{aligned} \frac{2x^3 - 2x^2 - 24x - 7}{x^2 - x - 12} &= 2x + \frac{-7}{x^2 - x - 12} \\ &= 2x + \frac{-7}{(x-4)(x+3)} \end{aligned}$$

Let $\frac{-7}{(x-4)(x+3)} = \frac{A}{x-4} + \frac{B}{x+3}$. (Ignore the $2x$ when expressing $\frac{-7}{(x-4)(x+3)}$ into its partial fractions.)

Multiply throughout by $(x-4)(x+3)$,

$$-7 = A(x+3) + B(x-4)$$

Let $x = 4$: $-7 = 7A$

$$A = -1$$

Let $x = -3$: $-7 = -7B$

$$B = 1$$

$$\therefore \frac{2x^3 - 2x^2 - 24x - 7}{x^2 - x - 12} = 2x - \frac{1}{x-4} + \frac{1}{x+3}$$

Example 19

Express $\frac{8x^2 - 5x + 2}{(3x + 2)(x^2 + 4)}$ in partial fractions.

Solution

Let $\frac{8x^2 - 5x + 2}{(3x + 2)(x^2 + 4)} = \frac{A}{3x + 2} + \frac{Bx + C}{x^2 + 4}$. (Note that $x^2 + 4$ cannot be factorised into 2 linear factors.)

Multiply throughout by $(3x + 2)(x^2 + 4)$,
 $8x^2 - 5x + 2 = A(x^2 + 4) + (Bx + C)(3x + 2)$

$$\text{Let } x = -\frac{2}{3}: \frac{80}{9} = \frac{40}{9}A$$

$$A = 2$$

$$\begin{aligned}\text{Let } x = 0: 2 &= 4A + 2C \\ &= 4(2) + 2C \\ 2C &= -6 \\ C &= -3\end{aligned}$$

Comparing coefficients of x^2 ,

$$\begin{aligned}8 &= A + 3B \\ &= 2 + 3B \\ 3B &= 6 \\ B &= 2\end{aligned}$$

$$\therefore \frac{8x^2 - 5x + 2}{(3x + 2)(x^2 + 4)} = \frac{2}{3x + 2} + \frac{2x - 3}{x^2 + 4}$$



Example 20

Express $\frac{9 - 4x}{(2x + 3)(x - 1)^2}$ in partial fractions.

Solution

$$\text{Let } \frac{9 - 4x}{(2x + 3)(x - 1)^2} = \frac{A}{2x + 3} + \frac{B}{x - 1} + \frac{C}{(x - 1)^2}.$$

Multiply throughout by $(2x + 3)(x - 1)^2$,

$$9 - 4x = A(x - 1)^2 + B(x - 1)(2x + 3) + C(2x + 3)$$

$$\text{Let } x = 1: 5 = 5C$$

$$C = 1$$

$$\text{Let } x = -\frac{3}{2}: 15 = \frac{25}{4}A$$

$$A = \frac{12}{5}$$

Comparing coefficients of x^2 ,

$$0 = A + 2B$$

$$0 = \frac{12}{5} + 2B$$

$$2B = -\frac{12}{5}$$

$$B = -\frac{6}{5}$$

$$\therefore \frac{9 - 4x}{(2x + 3)(x - 1)^2} = \frac{12}{5(2x + 3)} - \frac{6}{5(x - 1)} + \frac{1}{(x - 1)^2}$$

37. Cover-Up Rule

The “Cover-Up Rule” is a method to find the unknown numerators of partial fractions.

Given that $\frac{P(x)}{(ax + b)(cx + d)} = \frac{A}{ax + b} + \frac{B}{cx + d}$, where $P(x)$ is a linear polynomial,

$$A = \frac{P\left(-\frac{b}{a}\right)}{c\left(-\frac{b}{a}\right) + d} \quad \text{and} \quad B = \frac{P\left(-\frac{d}{c}\right)}{a\left(-\frac{d}{c}\right) + b}.$$

Example 21

Express $\frac{3x-1}{(x+3)(x-2)}$ in partial fractions.

Solution

$$\text{Let } \frac{3x-1}{(x+3)(x-2)} = \frac{A}{x+3} + \frac{B}{x-2}.$$

Method 1: Substitution

$$\frac{3x-1}{(x+3)(x-2)} = \frac{A}{x+3} + \frac{B}{x-2}$$

Multiply throughout by $(x+3)(x-2)$,

$$3x-1 = A(x-2) + B(x+3)$$

Let $x = 2$: $5 = 5B$ (Letting x be 2 leaves us with 1 unknown, B .)

$$B = 1$$

Let $x = -3$: $-10 = -5A$ (Letting x be -3 leaves us with 1 unknown, A .)

$$A = 2$$

$$\therefore \frac{3x-1}{(x+3)(x-2)} = \frac{2}{x+3} + \frac{1}{x-2}$$

Method 2: Cover-Up Rule

Using the Cover-Up Rule,

$$A = \frac{3(-3)-1}{-3-2} \text{ and } B = \frac{3(2)-1}{2+3}$$
$$= 2 \qquad = 1$$

$$\therefore \frac{3x-1}{(x+3)(x-2)} = \frac{2}{x+3} + \frac{1}{x-2}$$

UNIT 2

Quadratic Equations, Inequalities and Modulus Functions

Relationships between the Roots and Coefficients of a Quadratic Equation

1. If α and β are the roots of the quadratic equation $ax^2 + bx + c = 0$,

$$\text{Sum of roots, } \alpha + \beta = -\frac{b}{a}$$

$$\text{Product of roots, } \alpha\beta = \frac{c}{a}$$

i.e. $x^2 - (\alpha + \beta)x + \alpha\beta = 0$

2. In general,

$$x^2 - (\text{sum of roots})x + (\text{product of roots}) = 0$$

3. Some useful identities

(i) $\alpha^2 + \beta^2 = (\alpha + \beta)^2 - 2\alpha\beta$

(ii) $(\alpha - \beta)^2 = (\alpha + \beta)^2 - 4\alpha\beta$

(iii) $\alpha^4 - \beta^4 = (\alpha^2 + \beta^2)(\alpha + \beta)(\alpha - \beta)$

(iv) $\alpha^4 + \beta^4 = (\alpha^2 + \beta^2)^2 - 2\alpha^2\beta^2$

(v) $\alpha^3 - \beta^3 = (\alpha - \beta)[(\alpha + \beta)^2 - \alpha\beta]$

(vi) $\alpha^3 + \beta^3 = (\alpha + \beta)[(\alpha + \beta)^2 - 3\alpha\beta]$

Example 1

The roots of the quadratic equation $2x^2 - 5x = 4$ are α and β .

Find

(i) $\alpha^2 + \beta^2$,

(ii) $\frac{\alpha}{2\beta} + \frac{\beta}{2\alpha}$.

Solution

From $2x^2 - 5x = 4$, we have $2x^2 - 5x - 4 = 0$.

$$\alpha + \beta = -\frac{-5}{2} = \frac{5}{2}$$

$$\alpha\beta = \frac{-4}{2} = -2$$

(i) $\alpha^2 + \beta^2 = (\alpha + \beta)^2 - 2\alpha\beta$

$$= \left(\frac{5}{2}\right)^2 - 2(-2)$$

$$= \frac{41}{4}$$

(ii) $\frac{\alpha}{2\beta} + \frac{\beta}{2\alpha} = \frac{\alpha^2 + \beta^2}{2\alpha\beta}$

$$= \frac{41}{4} \div 2(-2)$$

$$= \frac{41}{16}$$

Example 2

Using your answers in Example 1, form a quadratic equation with integer coefficients whose roots are $\frac{\alpha}{2\beta}$ and $\frac{\beta}{2\alpha}$.

Solution

Sum of new roots, $\frac{\alpha}{2\beta} + \frac{\beta}{2\alpha} = -\frac{41}{16}$

Product of new roots, $\frac{\alpha}{2\beta} \times \frac{\beta}{2\alpha} = \frac{1}{4}$

\therefore New equation is $x^2 - \left(-\frac{41}{16}\right)x + \frac{1}{4} = 0$

i.e. $16x^2 + 41x + 4 = 0$.

Example 3

If α and β are the roots of the equation $2x^2 + 5x - 12 = 0$, where $\alpha > \beta$, find the value of each of the following.

(i) $\frac{1}{\alpha} + \frac{1}{\beta}$

(ii) $\alpha^2 + \beta^2$

Solution

$$\begin{aligned}\alpha + \beta &= -\frac{b}{a} \\ &= -\frac{5}{2} \\ &= -2\frac{1}{2}\end{aligned}$$

$$\begin{aligned}\alpha\beta &= \frac{c}{a} \\ &= -\frac{12}{2} \\ &= -6\end{aligned}$$

(i) $\frac{1}{\alpha} + \frac{1}{\beta} = \frac{\alpha + \beta}{\alpha\beta}$

$$\begin{aligned}&= \frac{-2\frac{1}{2}}{-6} \\ &= \frac{5}{12}\end{aligned}$$

(ii) $\alpha^2 + \beta^2 = (\alpha + \beta)^2 - 2\alpha\beta$

$$\begin{aligned}&= \left(-2\frac{1}{2}\right)^2 - 2(-6) \\ &= 18\frac{1}{4}\end{aligned}$$



Maximum and Minimum Values of Quadratic Functions

4. The quadratic function $ax^2 + bx + c$ can be expressed as $a(x + h)^2 + k$.

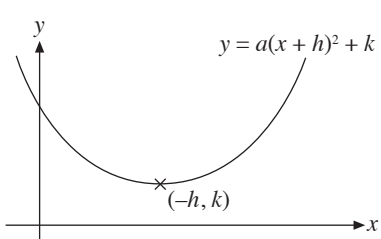
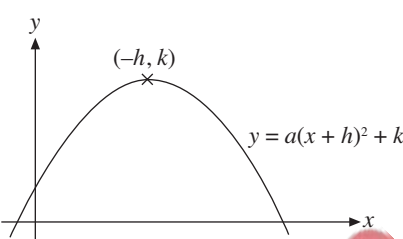
$a > 0$	$a < 0$
 <p>A Cartesian coordinate system showing a parabola opening upwards. The vertex is marked with an 'x' and labeled $(-h, k)$. The equation $y = a(x + h)^2 + k$ is written next to the curve.</p>	 <p>A Cartesian coordinate system showing a parabola opening downwards. The vertex is marked with an 'x' and labeled $(-h, k)$. The equation $y = a(x + h)^2 + k$ is written next to the curve.</p>
<p>Minimum value = k, when $x = -h$ Minimum point: $(-h, k)$</p>	<p>Maximum value = k, when $x = -h$ Maximum point: $(-h, k)$</p>

Sketching of Quadratic Graphs

5. Method of sketching a quadratic graph:

Step 1: Determine the shape of the graph from a .

Step 2: Express the function as $a(x + h)^2 + k$ to get the coordinates of the maximum or minimum point.

Step 3: Substitute $x = 0$ to find the y -intercept.

Step 4: Substitute $y = 0$ to find the x -intercept(s), if the roots are real.



Example 4

Sketch the function $y = x^2 - 1$.

Solution

Step 1: Since $y = x^2 - 1$ is a quadratic function and a is positive, the graph is U-shaped.

Step 2: Comparing with the form $a(x + h)^2 + k$, we get $a = 1$, which is greater than 0 so it has a minimum point.

From the function $y = x^2 - 1$, $h = 0$, $k = -1$. (We can express $x^2 - 1$ as $(x + 0)^2 + (-1)$ and compare with the form $a(x + h)^2 + k$.)

Step 3: When $x = 0$, $f(x) = -1$.

Step 4: When $y = 0$, $x = 1$ and -1 .

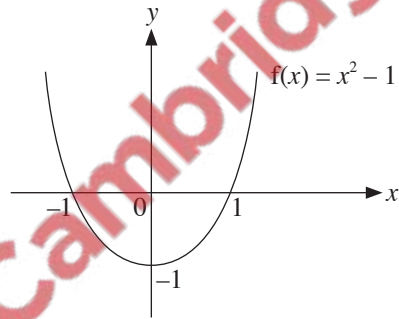

Quadratic Inequalities

6. If $(x-a)(x-b) > 0$,
then $x < a$ or $x > b$.

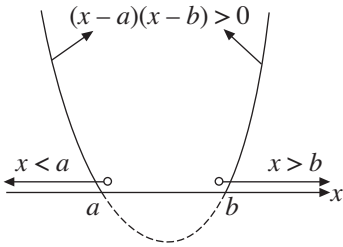

- If $(x-a)(x-b) \geq 0$,
then $x \leq a$ or $x \geq b$.

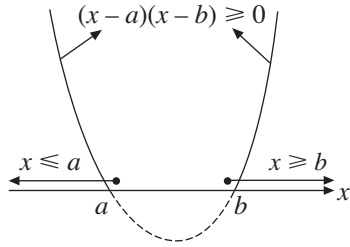

7. If $(x-a)(x-b) < 0$,
then $a < x < b$.

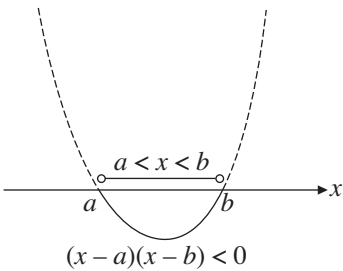

- If $(x-a)(x-b) \leq 0$,
then $a \leq x \leq b$.

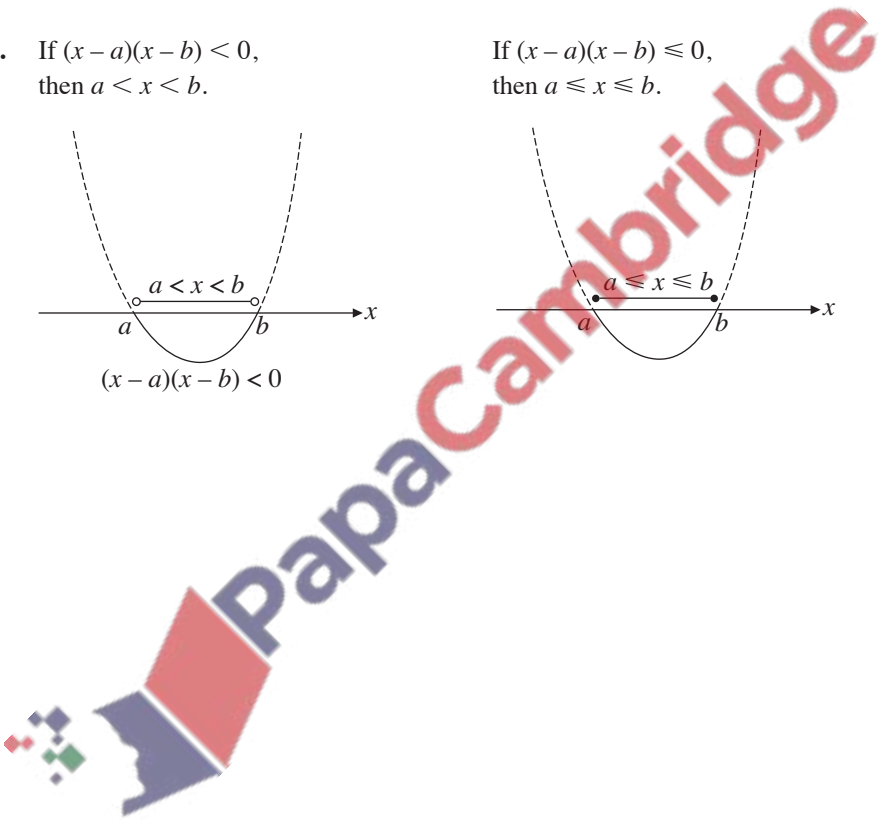
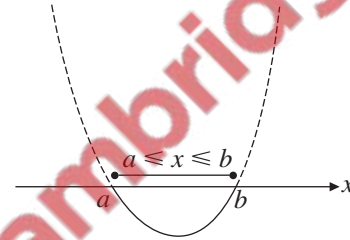

Example 5

Find the range of values of x for which $3x^2 - 4x + 6 \leq 7x$.

Solution

$3x^2 - 4x + 6 \leq 7x$ (When solving quadratic inequalities, ensure that the RHS of
 $3x^2 - 11x + 6 \leq 0$ the inequality is zero before factorising the expression on the
 $(3x - 2)(x - 3) \leq 0$ LHS.)

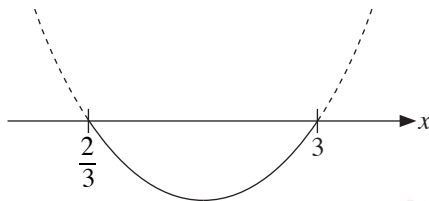

\therefore Range of values of x is $\frac{2}{3} \leq x \leq 3$

Roots of a Quadratic Equation

8. The roots of a quadratic equation $ax^2 + bx + c = 0$ are given by $x = \frac{-b \pm \sqrt{b^2 - 4ac}}{2a}$.
9. $b^2 - 4ac$ is called the discriminant.

10. A quadratic equation has no real roots when $b^2 - 4ac < 0$.

Given a quadratic expression $ax^2 - bx + c$,

it is found that:

given that $b^2 - 4ac < 0$ and $a > 0$, $ax^2 - bx + c > 0$ for all real values of x , and

given that $b^2 - 4ac < 0$ and $a < 0$, $ax^2 - bx + c < 0$ for all real values of x .

Example 6

Is the quadratic expression $5x^2 + 4x + 1$ greater than zero for all real values of x ?

Solution

$$\begin{aligned}\text{Discriminant} &= 4^2 - 4(5)(1) \\ &= -4\end{aligned}$$

Since $b^2 - 4ac < 0$ and $a > 0$, $5x^2 + 4x + 1 > 0$ for all real values of x .

Example 7

Find the range of values of k for which the equation $2x^2 + 5x - k = 0$ has no real roots.

Solution

$$\begin{aligned}2x^2 + 5x - k &= 0 \\ a = 2, b = 5, c &= -k\end{aligned}$$

For the equation to have no real roots,

$$\begin{aligned}b^2 - 4ac &< 0 \\ 5^2 - 4(2)(-k) &< 0 \\ 8k &< -25 \\ k &< -\frac{25}{8}\end{aligned}$$



Conditions for the Intersection of a Line and a Quadratic Curve

11.

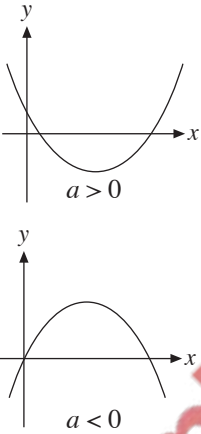
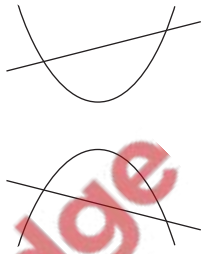
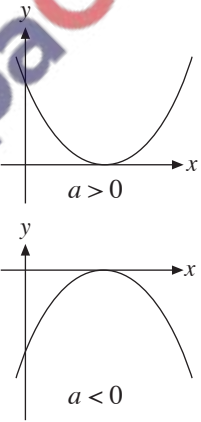
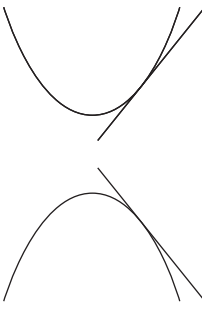
$b^2 - 4ac$	Nature of roots	Intersection of $y = ax^2 + bx + c$ with the x -axis	Intersection of quadratic curve with a straight line
> 0	2 real and distinct roots	<p>$y = ax^2 + bx + c$ cuts the x-axis at 2 distinct points</p>  <p>$a > 0$</p> <p>$a < 0$</p>	<p>Line intersects the curve at two distinct points</p> 
$= 0$	2 real and equal roots	<p>$y = ax^2 + bx + c$ touches the x-axis</p>  <p>$a > 0$</p> <p>$a < 0$</p>	<p>Line is a tangent to the curve</p> 

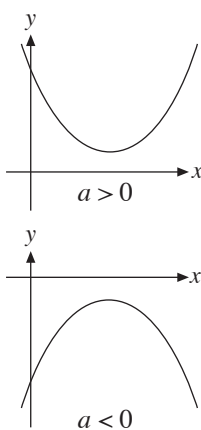
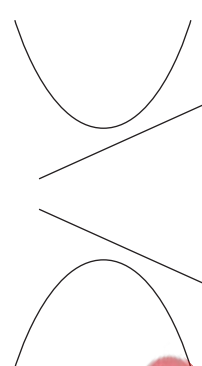
<p>< 0</p>	<p>No real roots</p>	<p>$y = ax^2 + bx + c$ lies entirely above or entirely below the x-axis i.e. curve is always positive ($a > 0$) or always negative ($a < 0$)</p> 	<p>Line does not intersect the curve</p> 
----------------------------	----------------------	--	--

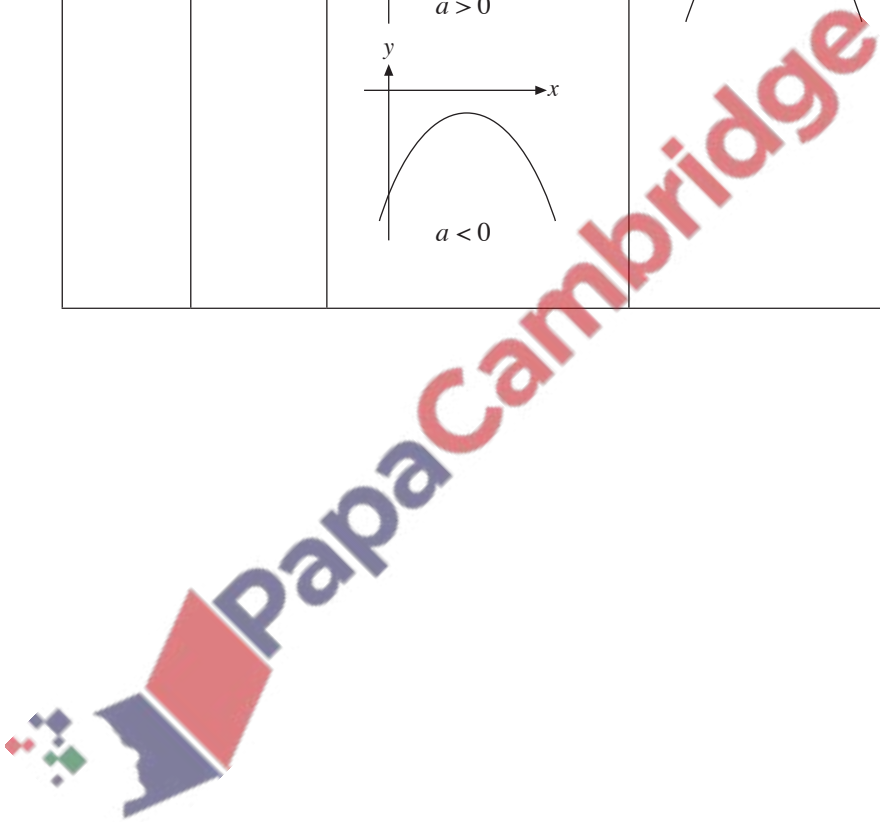

Example 8

Find the range of values of k given that the straight line $y = x - k$ cuts the curve $y = kx^2 + 9x$ at two distinct points.

Solution

$$y = x - k \quad \text{--- (1)}$$

$$y = kx^2 + 9x \quad \text{--- (2)}$$

Substitute (1) into (2): (Substitute (1) into (2) to obtain a quadratic equation in x .)

$$x - k = kx^2 + 9x$$

$$kx^2 + 8x + k = 0$$

Since the straight line cuts the curve at two distinct points,

Discriminant > 0

$$8^2 - 4(k)(k) > 0$$

$$64 - 4k^2 > 0$$

(Remember to invert the inequality sign when dividing by a negative number.)

$$k^2 - 16 < 0$$

$$(k + 4)(k - 4) < 0$$

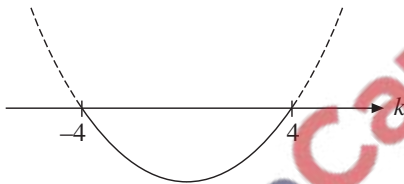

\therefore Range of values of k is $-4 < k < 4$



Example 9

Find the range of values of m for which the line $y = 5 - mx$ does not intersect the curve $x^2 + y^2 = 16$.

Solution

$$y = 5 - mx \quad \text{--- (1)}$$

$$x^2 + y^2 = 16 \quad \text{--- (2)}$$

Substitute (1) into (2):

$$x^2 + (5 - mx)^2 = 16$$

$$x^2 + m^2x^2 - 10mx + 25 = 16$$

$$(1 + m^2)x^2 - 10mx + 9 = 0$$

Since the line does not intersect the curve,

$$\text{Discriminant} < 0$$

$$(-10m)^2 - 4(1 + m^2)(9) < 0$$

$$100m^2 - 36 - 36m^2 < 0$$

$$64m^2 - 36 < 0$$

$$16m^2 - 9 < 0$$

$$(4m + 3)(4m - 3) < 0$$

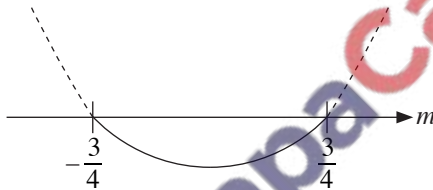

\therefore Range of values of m is $-\frac{3}{4} < m < \frac{3}{4}$

Absolute Valued Functions

12. The absolute value of a function $f(x)$, i.e. $|f(x)|$, refers to the numerical value of $f(x)$.
13. $|f(x)| = \begin{cases} f(x) & \text{if } f(x) \geq 0 \\ -f(x) & \text{if } f(x) < 0 \end{cases}$
14. $|f(x)| \geq 0$ for all values of x .

Example 10

Solve $|4x - 3| = 2x$.

Solution

$$\begin{aligned} |4x - 3| &= 2x \\ 4x - 3 &= 2x \quad \text{or} \quad 4x - 3 = -2x \\ 2x &= 3 & 6x &= 3 \\ x &= \frac{3}{2} & x &= \frac{1}{2} \end{aligned}$$

$$\therefore x = \frac{3}{2} \text{ or } x = \frac{1}{2}$$

Example 11

Solve $|2x - 3| = 15$.

Solution

$$\begin{aligned} |2x - 3| &= 15 \\ 2x - 3 &= 15 \quad \text{or} \quad 2x - 3 = -15 \\ 2x &= 18 & 2x &= -12 \\ x &= 9 & x &= -6 \end{aligned}$$

$$\therefore x = 9 \text{ or } x = -6$$

Example 12

Solve $|2x - 5| = |4 - x|$.

Solution

$$|2x - 5| = |4 - x|$$

$$2x - 5 = 4 - x \quad \text{or} \quad 2x - 5 = -(4 - x)$$

$$3x = 9 \qquad \qquad \qquad = -4 + x$$

$$x = 3 \qquad \qquad \qquad x = 1$$

$$\therefore x = 3 \text{ or } x = 1$$

Example 13

Solve $|x^2 - 3| = 2x$.

Solution

$$|x^2 - 3| = 2x$$

$$x^2 - 3 = 2x \qquad \text{or} \qquad x^2 - 3 = -2x$$

$$x^2 - 2x - 3 = 0 \qquad \qquad \qquad x^2 + 2x - 3 = 0$$

$$(x - 3)(x + 1) = 0 \qquad \qquad \qquad (x + 3)(x - 1) = 0$$

$$x = 3 \text{ or } x = -1 \qquad \qquad \qquad x = -3 \text{ or } x = 1$$

Checking the solutions, $x = 3$ or $x = 1$. (Substitute your answers into the original equation to check for any extraneous solutions.)

Example 14

Solve $|2x^2 - 5x| = x$.

Solution

$$|2x^2 - 5x| = x$$

$$2x^2 - 5x = x \quad \text{or} \quad 2x^2 - 5x = -x$$

$$2x^2 - 6x = 0 \quad 2x^2 - 4x = 0$$

$$2x(x - 3) = 0 \quad 2x(x - 2) = 0$$

$$x = 0 \text{ or } x = 3 \quad x = 0 \text{ or } x = 2$$

$$\therefore x = 0, x = 2 \text{ or } x = 3$$

Graphs of $y = |f(x)|$

15. Method of sketching the graph of $y = |f(x)|$:

Step 1: Sketch the graph of $y = f(x)$.

Step 2: The part of the graph below the x -axis is reflected in the x -axis.



Example 15

Sketch the graph of $y = 2x$.

Hence, sketch the graph of $y = |2x|$.

Solution

Sketch the graph $y = 2x$.

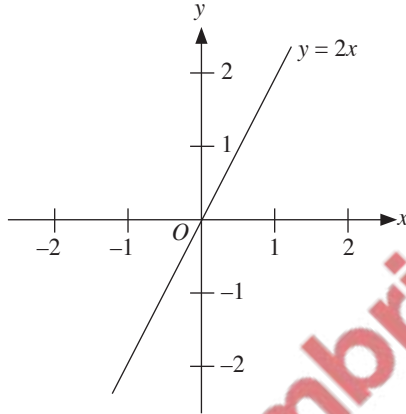

To draw $y = |2x|$, reflect the part of the graph that lies below the x -axis.

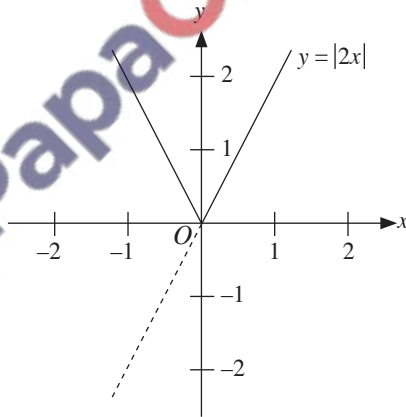

Example 16

Sketch the graph of $y = |2x + 1|$ for the domain $-1 \leq x \leq 1$ and state the corresponding range.

Solution

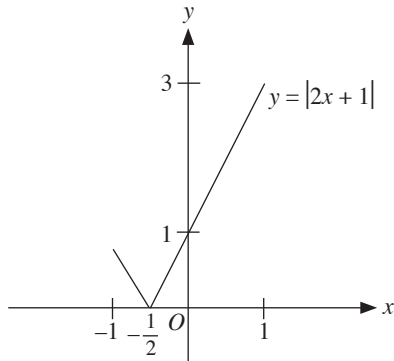

(It is necessary to find the coordinates of the critical points.)

\therefore Range is $0 \leq y \leq 3$

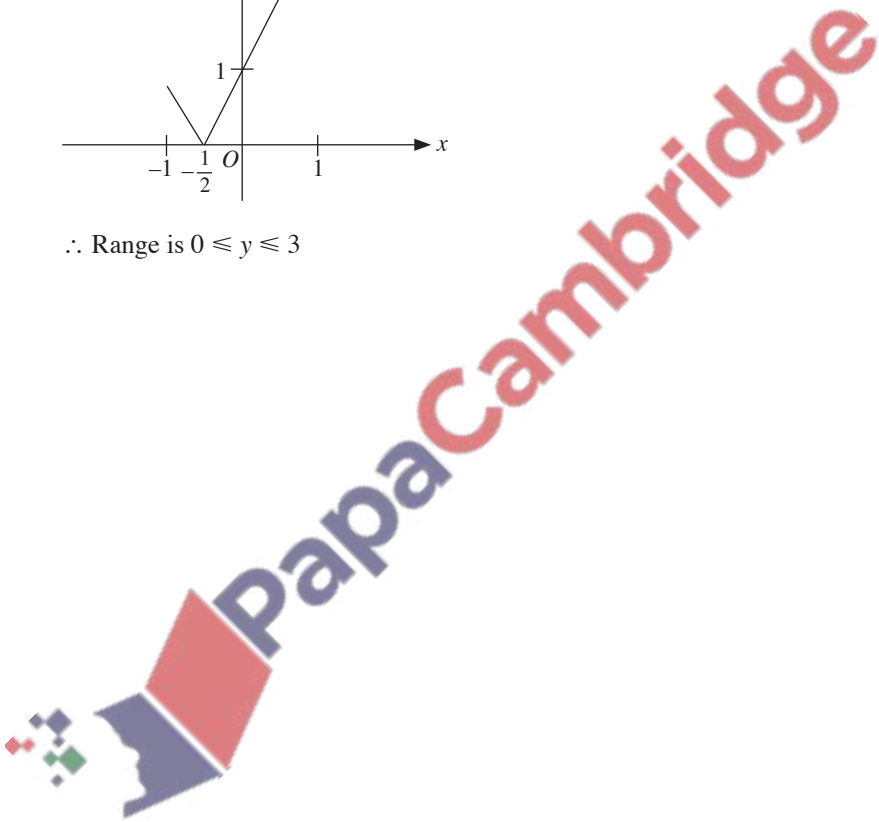

Example 17

Sketch the graph of $y = |x^2 - 2x - 3|$ for $-2 \leq x \leq 3$. State the corresponding range.

Solution

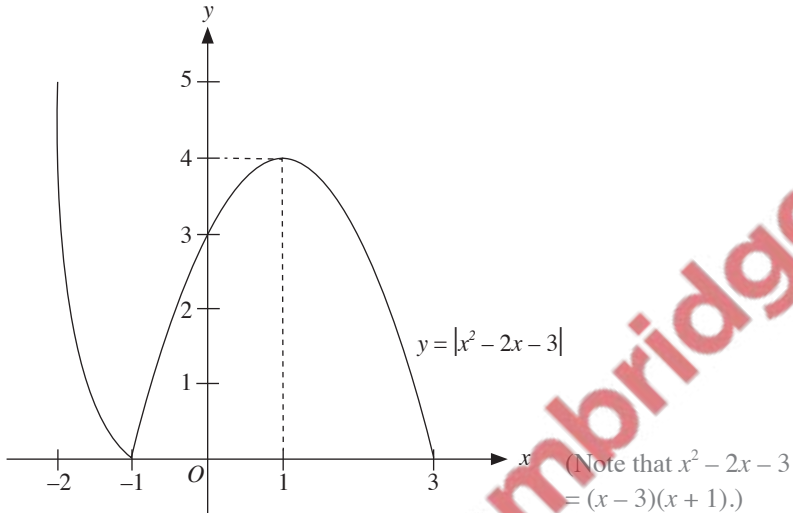

\therefore Range is $0 \leq y \leq 5$

16. If a function is defined as $y = a|bx + c| + d$,

(a) If $a > 0$, it is a V-shaped graph.

If $a < 0$, it is an inverted V-shaped graph.

(b) If $d > 0$, $y = a|bx + c|$ is translated up by d units.

If $d < 0$, $y = a|bx + c|$ is translated down by $|d|$ units.

Example 18

Sketch the graph of $y = 2|x| - 1$.

Solution

Step 1: Sketch the graph $y = 2|x|$.

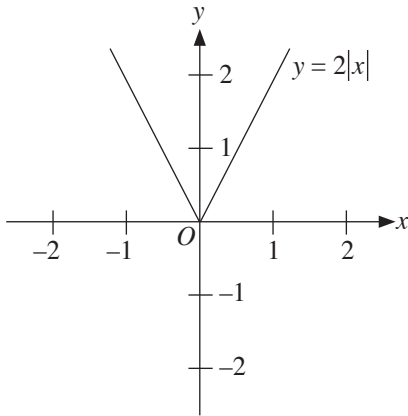

Step 2: Translate the graph down by 1 unit.

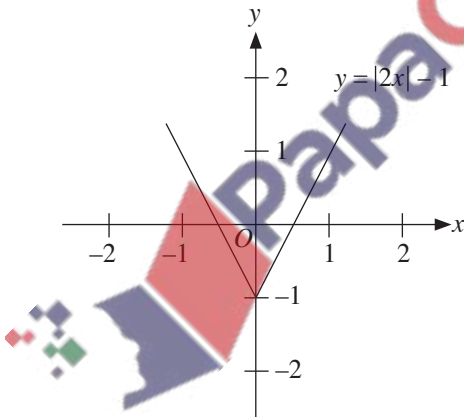

Binomial Theorem

1. For a positive integer n ,

$$(a + b)^n = a^n + \binom{n}{1}a^{n-1}b + \binom{n}{2}a^{n-2}b^2 + \dots + \binom{n}{r}a^{n-r}b^r + \dots + b^n$$

$$\text{where } \binom{n}{r} = \frac{n!}{r!(n-r)!} = \frac{n(n-1)\dots n(n-r+1)}{r!}$$

2. Number of terms in the expansion of $(a + b)^n$ is $n + 1$

3. Special case:

When $a = 1$,

$$(1 + b)^n = 1 + \binom{n}{1}b + \binom{n}{2}b^2 + \dots + \binom{n}{r}b^r + \dots + b^n$$



Example 1

Find the value of k and of n given that $(1 + kx)^n = 1 + 48x + 1008x^2 + \dots$.

Solution

$$\begin{aligned}(1 + kx)^n &= 1 + \binom{n}{1}(kx) + \binom{n}{2}(kx)^2 + \dots \quad (\text{Use the expansion of } (1 + b)^n.) \\ &= 1 + nkx + \frac{n(n-1)}{2} k^2x^2 + \dots\end{aligned}$$

By comparing coefficients,

$$\begin{aligned}x: \quad nk &= 48 && (\text{Compare coefficients to obtain a pair of simultaneous} \\ & k = \frac{48}{n} && \text{equations.}) \quad (1)\end{aligned}$$

$$x^2: \quad \frac{n(n-1)k^2}{2} = 1008$$

$$n(n-1)k^2 = 2016 \quad (2)$$

Substitute (1) into (2):

$$n(n-1) \frac{2304}{n^2} = 2016$$

$$2304n - 2304 = 2016n$$

$$n = 8$$

$$k = 6$$

$$\therefore k = 6, n = 8$$



PapaCambridge

Example 2

Write down the first 4 terms in the expansion of $(1 + 2x)^7$ in ascending powers of x .
Hence, find the coefficient of x^3 in the expansion of $(1 + 2x + 3x^2)(1 + 2x)^7$.

Solution

$$\begin{aligned}(1 + 2x)^7 &= 1 + \binom{7}{1}(2x) + \binom{7}{2}(2x)^2 + \binom{7}{3}(2x)^3 + \dots \quad (\text{Use the expansion of } (1 + b)^n.) \\ &= 1 + 14x + 84x^2 + 280x^3 + \dots\end{aligned}$$

$$\begin{aligned}(1 + 2x + 3x^2)(1 + 2x)^7 &= (1 + 2x + 3x^2)(1 + 14x + 84x^2 + 280x^3 + \dots) \\ &= \dots + 280x^3 + 168x^3 + 42x^3 + \dots \quad (\text{There is no need to obtain terms other than } x^3.) \\ &= \dots + 490x^3 + \dots\end{aligned}$$

\therefore Coefficient of x^3 is 490

The notation $n!$

4. $n! = n \times (n - 1) \times (n - 2) \times \dots \times 3 \times 2 \times 1$

5. Some useful rules:

- $\binom{n}{0} = 1$

- $\binom{n}{1} = n$

- $\binom{n}{2} = \frac{n(n-1)}{2!}$

- $\binom{n}{3} = \frac{n(n-1)(n-2)}{3!}$

- $\binom{n}{n} = 1$

Example 3

Find the value of n given that, in the expansion of $(3 + 2x)^n$, the coefficients of x^2 and x^3 are in the ratio 3 : 4.

Solution

$$\begin{aligned}(3 + 2x)^n &= \dots + \binom{n}{2} 3^{n-2} (2x)^2 + \binom{n}{3} 3^{n-3} (2x)^3 + \dots \\ &= \dots + \binom{n}{2} 3^{n-2} (4x^2) + \binom{n}{3} 3^{n-3} (8x^3) + \dots\end{aligned}$$

$$\frac{\binom{n}{2} 3^{n-2} (4)}{\binom{n}{3} 3^{n-3} (8)} = \frac{3}{4}$$

$$\frac{\frac{n(n-1)}{2} \cdot 3}{\frac{n(n-1)(n-2)}{6} \cdot 2} = \frac{3}{4}$$

$$n = 8$$

Example 4

Find the first 4 terms in the expansion of $(1 + 2x)^7$ in ascending powers of x . Use your result to estimate the value of 1.02^7 .

Solution

$$\begin{aligned}(1 + 2x)^7 &= 1 + \binom{7}{1} (2x) + \binom{7}{2} (2x)^2 + \binom{7}{3} (2x)^3 + \dots \\ &= 1 + 14x + 84x^2 + 280x^3 + \dots\end{aligned}$$

Let $(1 + 2x)^7 = 1.02^7$, then $x = 0.01$.

$$\begin{aligned}1.02^7 &= 1 + 14(0.01) + 84(0.01)^2 + 280(0.01)^3 + \dots \\ &= 1.148\ 68\end{aligned}$$

Example 5

Expand $\left(1 + \frac{x}{2}\right)^5$ in ascending powers of x . Hence, deduce the expansion of

(i) $\left(1 - \frac{x}{2}\right)^5$, (ii) $\left(1 + \frac{x}{2}\right)^5 + \left(1 - \frac{x}{2}\right)^5$.

Using your answers in (i) and (ii), find the exact value of $1.05^5 + 0.95^5$.

Solution

$$\begin{aligned}\left(1 + \frac{x}{2}\right)^5 &= 1 + \binom{5}{1}\left(\frac{x}{2}\right) + \binom{5}{2}\left(\frac{x}{2}\right)^2 + \binom{5}{3}\left(\frac{x}{2}\right)^3 + \binom{5}{4}\left(\frac{x}{2}\right)^4 + \binom{5}{5}\left(\frac{x}{2}\right)^5 \\ &= 1 + \frac{5}{2}x + \frac{5}{2}x^2 + \frac{5}{4}x^3 + \frac{5}{16}x^4 + \frac{1}{32}x^5\end{aligned}$$

(i) $\left(1 - \frac{x}{2}\right)^5 = \left[1 + \left(-\frac{x}{2}\right)\right]^5$

$$= 1 - \frac{5}{2}x + \frac{5}{2}x^2 - \frac{5}{4}x^3 + \frac{5}{16}x^4 - \frac{1}{32}x^5$$

(ii) $\left(1 + \frac{x}{2}\right)^5 + \left(1 - \frac{x}{2}\right)^5 = \left[1 + \frac{5}{2}x + \frac{5}{2}x^2 + \frac{5}{4}x^3 + \frac{5}{16}x^4 + \frac{1}{32}x^5\right]$
$$+ \left[1 - \frac{5}{2}x + \frac{5}{2}x^2 - \frac{5}{4}x^3 + \frac{5}{16}x^4 - \frac{1}{32}x^5\right]$$
$$= 2 + 5x^2 + \frac{5}{8}x^4$$

Let $\left(1 + \frac{x}{2}\right)^5 + \left(1 - \frac{x}{2}\right)^5 = 1.05^5 + 0.95^5$.

By inspection,

$$x = 0.1$$

$$\begin{aligned}\therefore 1.05^5 + 0.95^5 &= 2 + 5(0.1)^2 + \frac{5}{8}(0.1)^4 \\ &= 2.050\ 0625\end{aligned}$$

Example 6

Write down the expansion of $(1 + p)^6$ in ascending powers of p . Hence, find the first 3 terms in the expansion of $(1 + 2x + 2x^2)^6$ in ascending powers of x . Use your result to find the value of $1.002\ 002^6$ correct to 6 decimal places.

Solution

$$\begin{aligned}(1 + p)^6 &= 1 + \binom{6}{1}p + \binom{6}{2}p^2 + \binom{6}{3}p^3 + \binom{6}{4}p^4 + \binom{6}{5}p^5 + \binom{6}{6}p^6 \\ &= 1 + 6p + 15p^2 + 20p^3 + 15p^4 + 6p^5 + p^6\end{aligned}$$

By comparing $(1 + p)^6$ with $(1 + 2x + 2x^2)^6$,

$$p = 2x + 2x^2$$

$$\begin{aligned}(1 + 2x + 2x^2)^6 &= 1 + 6(2x + 2x^2) + 15(2x + 2x^2)^2 + \dots \quad (\text{The first 3 terms consist of} \\ &= 1 + 12x + 12x^2 + 60x^2 + \dots \quad \text{the constant, the term in } x \\ &= 1 + 12x + 72x^2 + \dots \quad \text{and the term in } x^2.)\end{aligned}$$

$$1.002\ 002 = 1 + 2(0.001) + 2(0.001)^2$$

Let $x = 0.001$.

$$\begin{aligned}\therefore 1.002\ 002^6 &= 1 + 12(0.001) + 72(0.001)^2 + \dots \\ &= 1.012\ 072 \quad (\text{to 6 d.p.})\end{aligned}$$

General Term

6. The $(r + 1)^{\text{th}}$ term is $\binom{n}{r} a^{n-r} b^r$.

Example 7

Find the 8th term in the expansion of $(3 + x)^{12}$ in ascending powers of x .

Solution

$$(r + 1)^{\text{th}} \text{ term} = \binom{12}{r} 3^{12-r} x^r$$

$$8^{\text{th}} \text{ term} = (7 + 1)^{\text{th}} \text{ term}$$

$$= \binom{12}{7} 3^{12-7} x^7$$

$$= 792 (3^5) x^7$$

$$= 192\,456x^7$$

Example 8

In the expansion of $(1 + x)^n$ in ascending powers of x , the coefficient of the third term is 21. Find the value of n .

Solution

In the expansion of $(1 + x)^n$, the $(r + 1)^{\text{th}}$ term is $\binom{n}{r} x^r$.

Hence, in the expansion of $(1 + x)^n$, the third term is $\binom{n}{2} x^2 = \frac{n(n-1)}{2} x^2$.

∴ The coefficient of the third term is:

$$\frac{n(n-1)}{2} = 21$$

$$n(n-1) = 42$$

$$n^2 - n - 42 = 0$$

$$\diamond (n+6)(n-7) = 0$$

$$n = -6 \text{ or } n = 7 \quad (\text{Since } n \text{ is a positive integer, reject } n = -6.)$$

$$\therefore n = 7$$

Term Independent of x

7. Term independent of x refers to the constant term.

Example 9

Find the term independent of x in the expansion of $\left(x^2 + \frac{1}{x}\right)^{12}$.

Solution

Using $T_{r+1} = \binom{n}{r} a^{n-r} b^r$ (Recall the formula for the general term.)

$$\begin{aligned} T_{r+1} &= \binom{12}{r} (x^2)^{12-r} \left(\frac{1}{x}\right)^r \\ &= \binom{12}{r} x^{24-2r} \left(\frac{1}{x^r}\right) \\ &= \binom{12}{r} x^{24-3r} \end{aligned}$$

$24 - 3r = 0$ (Term independent of x refers to the constant term, i.e. x^0 .)
 $r = 8$

\therefore Term independent of x is $\binom{12}{8} x^{24-3(8)} = 495$

Example 10

Find the term independent of x in the expansion of $(2x + 3)^4$.

Solution

In the expansion of $(2x + 3)^4$, the $(r + 1)^{\text{th}}$ term is $\binom{4}{r} (2x)^{4-r} 3^r$.

For the term independent of x ,

$$\begin{aligned} 4 - r &= 0 \\ r &= 4 \end{aligned}$$

\therefore Term independent of x is $\binom{4}{4} (2x)^{4-4} 3^4 = 81$

UNIT 4

Indices, Surds and Logarithms

Rules of Indices

1. (a) $a^m \times a^n = a^{m+n}$ (b) $a^m \div a^n = a^{m-n}$
(c) $(a^m)^n = a^{mn}$ (d) $a^0 = 1$, provided $a \neq 0$
(e) $a^{-n} = \frac{1}{a^n}$ (f) $a^{\frac{1}{n}} = \sqrt[n]{a}$
(g) $a^{\frac{m}{n}} = \sqrt[n]{a^m} = (\sqrt[n]{a})^m$ (h) $(a \times b)^n = a^n \times b^n$
(i) $\left(\frac{a}{b}\right)^n = \frac{a^n}{b^n}$, provided $b \neq 0$

Example 1

Simplify $81^{\frac{3}{2}} \times 2^6 \div 6^3$.

Solution

$$\begin{aligned}81^{\frac{3}{2}} \times 2^6 \div 6^3 &= (3^4)^{\frac{3}{2}} \times 2^6 \div 6^3 \\&= 3^6 \times 2^6 \div 6^3 \\&= (3 \times 2)^6 \div 6^3 \\&= 6^3 \\&= 216\end{aligned}$$

Example 2

Simplify each of the following.

(i) $3^{2n} \times 15^{3n} \div 5^n$

(ii) $\frac{25 \times 5^{n-2}}{5^n - 5^{n-1}}$

Solution

(i) $3^{2n} \times 15^{3n} \div 5^n = 3^{2n} \times 3^{3n} \times 5^{3n} \div 5^n$ (Recall that $(a \times b)^n = a^n \times b^n$.)
 $= 3^{5n} \times 5^{2n}$

(ii) $\frac{25 \times 5^{n-2}}{5^n - 5^{n-1}} = \frac{5^2 \times 5^{n-2}}{5^{n-1}(5-1)}$ (5^{n-1} is a common factor in the denominator.)
 $= \frac{5^n}{4(5^{n-1})}$
 $= \frac{5}{4}$

Definition of a Surd

2. A surd is an irrational root of a real number, e.g. $\sqrt{2}$ and $\sqrt{3}$.

Operations on Surds

3. (a) $\sqrt{a} \times \sqrt{a} = a$

(b) $\sqrt{a} \times \sqrt{b} = \sqrt{ab}$

(c) $\frac{\sqrt{a}}{\sqrt{b}} = \sqrt{\frac{a}{b}}$

(d) $m\sqrt{a} + n\sqrt{a} = (m+n)\sqrt{a}$

(e) $m\sqrt{a} - n\sqrt{a} = (m-n)\sqrt{a}$

Example 3

Simplify $\sqrt{8} \div \sqrt{2}$.

Solution

$$\begin{aligned}\sqrt{8} \div \sqrt{2} &= \sqrt{\frac{8}{2}} \\ &= \sqrt{4} \\ &= 2\end{aligned}$$

Example 4

Given that $(a + \sqrt{2})(3 + b\sqrt{2}) = 8 + 5\sqrt{2}$, find the possible values of a and of b .

Solution

$$\begin{aligned}(a + \sqrt{2})(3 + b\sqrt{2}) &= 3a + ab\sqrt{2} + 3\sqrt{2} + 2b \\ &= 3a + 2b + (ab + 3)\sqrt{2}\end{aligned}$$

By comparing,

$$\begin{aligned}3a + 2b &= 8 & \text{--- (1) (Equate the rational terms and the irrational terms to obtain} \\ ab + 3 &= 5 & \text{--- (2) 2 equations.)}\end{aligned}$$

From (2),

$$ab = 2$$

$$b = \frac{2}{a} \quad \text{--- (3)}$$

Substitute (3) into (1):

$$3a + 2\left(\frac{2}{a}\right) = 8$$

$$3a^2 - 8a + 4 = 0$$

$$(3a - 2)(a - 2) = 0$$

$$a = \frac{2}{3} \quad \text{or} \quad a = 2$$

$$b = 3 \quad \quad b = 1$$

$$\therefore a = \frac{2}{3}, b = 3 \text{ or } a = 2, b = 1$$

Conjugate Surds

- $a\sqrt{m} + b\sqrt{n}$ and $a\sqrt{m} - b\sqrt{n}$ are conjugate surds.
- $(a\sqrt{m} + b\sqrt{n})(a\sqrt{m} - b\sqrt{n}) = a^2m - b^2n$, which is a rational number.
- The product of a pair of conjugate surds is always a rational number.

Example 5

Simplify $(\sqrt{3} + 3\sqrt{2})(\sqrt{3} - 3\sqrt{2})$.

Solution

$$\begin{aligned}(\sqrt{3} + 3\sqrt{2})(\sqrt{3} - 3\sqrt{2}) &= (\sqrt{3})^2 - 9(\sqrt{2})^2 \\ &= 3 - 9(2) \\ &= -15\end{aligned}$$

Rationalising the Denominator

7. To rationalise the denominator of a surd is to make the denominator a rational number.

$$\begin{aligned}\text{(a)} \quad \frac{\sqrt{b}}{\sqrt{a}} &= \frac{\sqrt{b}}{\sqrt{a}} \times \frac{\sqrt{a}}{\sqrt{a}} \\ &= \frac{\sqrt{ab}}{a}\end{aligned}$$

$$\begin{aligned}\text{(b)} \quad \frac{1}{\sqrt{a} + \sqrt{b}} &= \frac{1}{\sqrt{a} + \sqrt{b}} \times \frac{\sqrt{a} - \sqrt{b}}{\sqrt{a} - \sqrt{b}} \\ &= \frac{\sqrt{a} - \sqrt{b}}{a - b}\end{aligned}$$

Example 6

Rationalise the denominator of $\frac{3\sqrt{2} + 2}{3\sqrt{2} + 3}$.

Solution

$$\begin{aligned}\frac{3\sqrt{2} + 2}{3\sqrt{2} + 3} &= \frac{3\sqrt{2} + 2}{3\sqrt{2} + 3} \times \frac{3\sqrt{2} - 3}{3\sqrt{2} - 3} \\ &= \frac{(3\sqrt{2})(3\sqrt{2}) + 6\sqrt{2} - 9\sqrt{2} - 6}{(3\sqrt{2})^2 - 3^2} \\ &= \frac{12 - 3\sqrt{2}}{9} \\ &= \frac{4 - \sqrt{2}}{3}\end{aligned}$$

Example 7

The sides of rectangle $ABCD$ are $(3 + \sqrt{8})$ cm and $\left(5 - \frac{4}{\sqrt{2}}\right)$ cm in length.

Express, in the form of $a + b\sqrt{2}$, where a and b are integers,

- (i) the area of the rectangle in cm^2 ,
- (ii) the area of a square in cm^2 , given that AC is one of its sides.

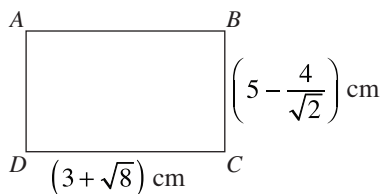

Solution

- (i) Area of rectangle $ABCD = (3 + \sqrt{8})\left(5 - \frac{4}{\sqrt{2}}\right)$
$$= 15 - \frac{12}{\sqrt{2}} + 5\sqrt{8} - 4\sqrt{4}$$

(Rationalise the denominator of $\frac{12}{\sqrt{2}}$.)

$$= 15 - \frac{12\sqrt{2}}{2} + 5(2\sqrt{2}) - 8$$
$$= (7 + 4\sqrt{2}) \text{ cm}^2$$
- (ii) Area of square $= AC^2$
$$= (3 + \sqrt{8})^2 + \left(5 - \frac{4}{\sqrt{2}}\right)^2$$

(Apply Pythagoras' Theorem.)

$$= 9 + 6\sqrt{8} + 8 + 25 - \frac{40}{\sqrt{2}} + 8$$
$$= 50 + 12\sqrt{2} - 20\sqrt{2}$$
$$= (50 - 8\sqrt{2}) \text{ cm}^2$$

Common Logarithms and Natural Logarithms

8. \log_{10} is called the common logarithm and it is represented by \lg .
9. \log_e is called the natural logarithm and it is represented by \ln .

Laws of Logarithms

10. (a) $\log_a x + \log_a y = \log_a xy$ (b) $\log_a x - \log_a y = \log_a \frac{x}{y}$
(c) $\log_a x^r = r \log_a x$

More Formulae on Logarithms

11. (a) $\log_a b = \frac{\log_c b}{\log_c a}$ (Change of Base Formula)
(b) $\log_a 1 = 0$
(c) $\log_a a = 1$
(d) $a^{\log_a y} = y$ (For $\log_a y$ to be a real number, $y > 0$)
(e) $\log_a a^x = x$

Example 8

Simplify $\log_3 81 - \log_5 125 + \log_{\sqrt{2}} 8$.

Solution

$$\begin{aligned}\log_3 81 - \log_5 125 + \log_{\sqrt{2}} 8 &= \log_3 3^4 - \log_5 5^3 + \frac{\log_2 8}{\log_2 \sqrt{2}} \\ &= 4 \log_3 3 - 3 \log_5 5 + \frac{3 \log_2 2}{\frac{1}{2} \log_2 2} \\ &= 4 - 3 + 6 \\ &= 7\end{aligned}$$

Solving Exponential Equations

12. Given $a^x = b$,

- If b can be expressed as a power of a , e.g. $b = a^y$, then $a^x = a^y \Rightarrow x = y$.
- If b cannot be expressed as a power of a ,
 - take common logarithms on both sides, i.e. $x \lg a = \lg b \Rightarrow x = \frac{\lg b}{\lg a}$, or
 - take natural logarithms on both sides if $a = e$, i.e. $x \ln e = \ln b \Rightarrow x = \ln b$

Example 9

Solve the exponential equation $9 = 3^{4x}$.

Solution

$$9 = 3^{4x}$$

$$3^2 = 3^{4x}$$

$$2 = 4x$$

$$x = \frac{1}{2}$$

Example 10

Solve the equation $3e^y - 5 = 2e^{-y}$.

Solution

$$3e^y - 5 = 2e^{-y}$$

$$3e^y - 5 - \frac{2}{e^y} = 0$$

$$3(e^y)^2 - 5e^y - 2 = 0 \quad (\text{Multiply by } e^y.)$$

Let $w = e^y$.

$$3w^2 - 5w - 2 = 0$$

$$(3w + 1)(w - 2) = 0$$

$$w = -\frac{1}{3} \quad \text{or} \quad w = 2$$

$$e^y = -\frac{1}{3} \quad e^y = 2 \quad (\text{Note that } e^y > 0.)$$

$$(\text{no solution}) \quad y = \ln 2$$

$$= 0.693 \quad (\text{to 3 s.f.})$$

13. Given $p(a^{2x}) + q(a^x) + r = 0$,

Step 1: Substitute $u = a^x$ to get a quadratic equation $pu^2 + qu + r = 0$.

Step 2: Solve for u and deduce the value(s) of x .

Example 11

Solve the exponential equation $2^{2x+1} = 6(2^x) - 4$.

Solution

$$2^{2x+1} = 6(2^x) - 4$$

$$(2^x)^2(2) = 6(2^x) - 4$$

Let $2^x = y$.

$$2y^2 = 6y - 4$$

$$2y^2 - 6y + 4 = 0$$

$$y^2 - 3y + 2 = 0$$

$$(y - 2)(y - 1) = 0$$

$$y = 2 \quad \text{or} \quad y = 1$$

$$2^x = 2^1 \quad \quad \quad 2^x = 2^0$$

$$x = 1 \quad \quad \quad x = 0$$

Example 12

Without using a calculator, solve the equation $9^x - \frac{28}{3}(3^x) + 3 = 0$.

Solution

$$9^x - \frac{28}{3}(3^x) + 3 = 0$$

$$3(9^x) - 28(3^x) + 9 = 0$$

$$3(3^x)^2 - 28(3^x) + 9 = 0 \quad (\text{Ensure that the exponential terms have the same base.})$$

Let $y = 3^x$.

$$3y^2 - 28y + 9 = 0$$

$$(3y - 1)(y - 9) = 0 \quad (\text{Factorise the quadratic expression.})$$

$$y = \frac{1}{3} \quad \text{or} \quad y = 9$$

$$3^x = \frac{1}{3} \quad \quad \quad 3^x = 9$$

$$x = -1 \quad \quad \quad \text{or} \quad x = 2$$

Solving Logarithmic Equations

14. To solve logarithmic equations,

Step 1: Change the bases of the logarithmic functions to the same base.

We usually choose the smaller as the final base.

Step 2: Use one of the following methods to solve the equations.

(a) If $\log_a x = \log_a y$, then $x = y$ and vice versa.

(b) If $\log_a x = b$, then $x = a^b$.

(c) Use the laws of logarithms to combine the terms into the forms described in method (a) or (b).

Example 13

Solve the equation $\log_a 32x - \log_a (2x^2 + x - 54) = 3 \log_a 2$.

Solution

$$\log_a 32x - \log_a (2x^2 + x - 54) = 3 \log_a 2$$

$$\log_a \frac{32x}{2x^2 + x - 54} = \log_a 2^3$$

$$\frac{32x}{2x^2 + x - 54} = 8$$

$$32x = 16x^2 + 8x - 432$$

$$16x^2 - 24x - 432 = 0$$

$$2x^2 - 3x - 54 = 0$$

$$(2x + 9)(x - 6) = 0$$

$x = -\frac{9}{2}$ (rejected) or $x = 6$ (Substitute your answers into the original equation to check if any solution needs to be rejected.)

Example 14

Solve the equation $\log_3(x + 2) = 5$.

Solution

$$\log_3(x + 2) = 5$$

$$x + 2 = 3^5$$

$$x = 241$$

Example 15

(a) Solve the equation $\lg(6x + 4) - \lg(x - 6) = 1$.

(b) Find the value of x given that $e^{x-e} = 10$.

Solution

(a) $\lg(6x + 4) - \lg(x - 6) = 1$

$$\lg \frac{6x + 4}{x - 6} = 1$$

$$\frac{6x + 4}{x - 6} = 10 \quad (\text{Change to the exponential form.})$$

$$6x + 4 = 10x - 60$$

$$4x = 64$$

$$x = 16$$

(b) $e^{x-e} = 10$

$$x - e = \ln 10 \quad (\text{Use } \ln \text{ instead of } \lg \text{ because } \ln e = 1.)$$

$$x = e + \ln 10$$

$$= 5.02 \quad (\text{to 3 s.f.})$$

Example 16

Solve the simultaneous equations

$$\begin{aligned}e\sqrt{e^x} &= e^{2y}, \\ \log_4(x+2) &= 1 + \log_2 y.\end{aligned}$$

Solution

$$e\sqrt{e^x} = e^{2y} \quad \text{--- (1)}$$

$$\log_4(x+2) = 1 + \log_2 y \quad \text{--- (2)}$$

From (1),

$$e^1 e^{\frac{x}{2}} = e^{2y}$$

$$e^{1+\frac{x}{2}} = e^{2y}$$

$$1 + \frac{x}{2} = 2y$$

$$x = 4y - 2 \quad \text{--- (3)}$$

From (2),

$$\frac{\log_2(x+2)}{\log_2 4} = 1 + \log_2 y \quad \text{(Apply the Change of Base Formula.)}$$

$$\log_2(x+2) = 2 + 2 \log_2 y \quad \text{(Rearrange the logarithmic terms to one side of the equation.)}$$

$$\log_2(x+2) - \log_2 y^2 = 2$$

$$\log_2 \frac{x+2}{y^2} = 2$$

$$\frac{x+2}{y^2} = 4$$

$$x = 4y^2 - 2 \quad \text{--- (4)}$$

Substitute (3) into (4):

$$4y - 2 = 4y^2 - 2$$

$$4y^2 - 4y = 0$$

$$4y(y-1) = 0$$

$$y = 0$$

$$\text{or } y = 1$$

$$x = -2 \text{ (rejected) } \quad x = 2$$

$$\therefore x = 2, y = 1$$

(Substitute your answers into the original equations to check if any solutions need to be rejected.)

Example 17

At the beginning of 1980, the number of mice in a colony was estimated at 50 000. The number increased so that, after n years, the number would be $50\,000 \times e^{0.05n}$.

Estimate

- (i) the population of the mice, correct to the nearest thousand, at the beginning of the year 2000;
- (ii) the year during which the population would first exceed 100 000.

Solution

- (i) At the beginning of year 2000, $n = 20$.

$$\begin{aligned}\therefore \text{Population of the mice} &= 50\,000 \times e^{0.05(20)} \\ &\approx 136\,000 \text{ (to the nearest thousand)}\end{aligned}$$

- (ii) Let $50\,000 \times e^{0.05n} = 100\,000$

$$\begin{aligned}e^{0.05n} &= 2 \\ 0.05n &= \ln 2\end{aligned}$$

$$n = 13.86$$

\therefore The population will exceed 100 000 in the year 1993.

Graphs of Exponential Functions

15. Graphs of $y = a^x$

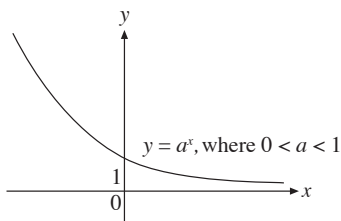
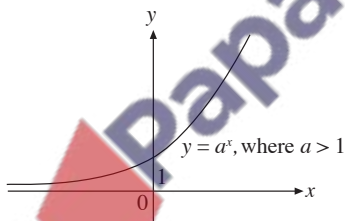

The graph of $y = a^x$ must pass through the point $(0, 1)$ because $a^0 = 1$.

Graphs of Logarithmic Functions

16. Graphs of $y = \log_a x$

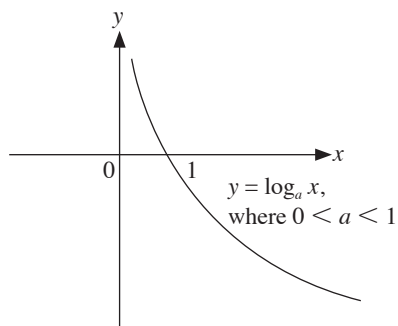
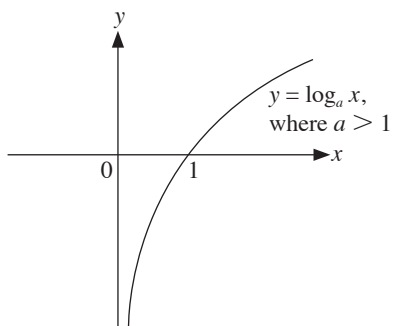

Example 18

Sketch the graph of each of the following functions.

(a) $y = e^{x-1} + 1$

(b) $y = 2e^{1-3x}$

(c) $y = \ln(2x - 3)$

(d) $y = \ln(5 - 3x)$

Solution

(a)

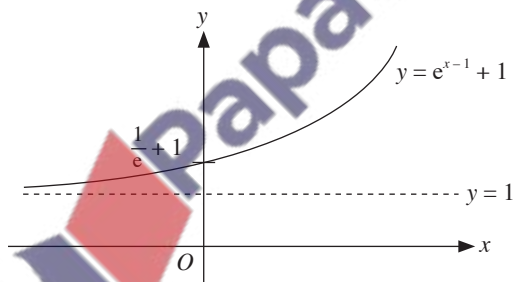

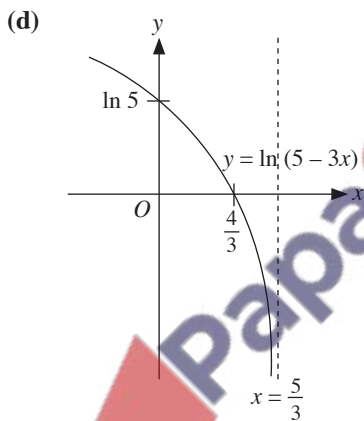
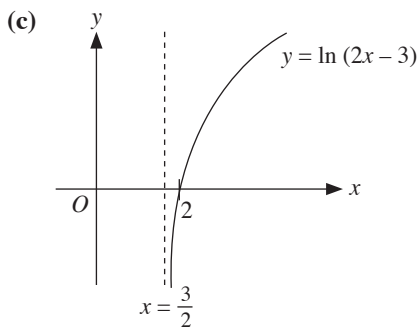
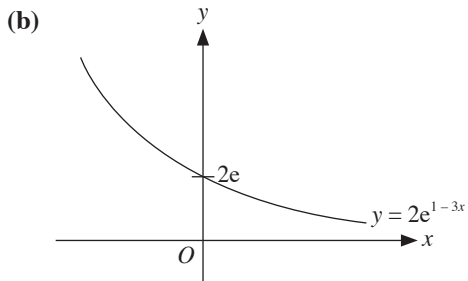

Example 19

Sketch the graph of $y = e^{x+1}$. By drawing a suitable straight line on the same graph, find the number of solutions of the equation $x + 1 = \ln(5 - 2x)$.

Solution

$$x + 1 = \ln(5 - 2x)$$

$$e^{x+1} = 5 - 2x$$

Draw $y = 5 - 2x$.

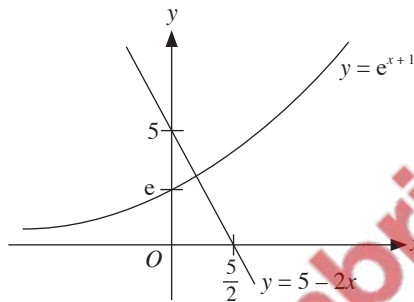

\therefore There is 1 solution.



UNIT 5

Coordinate Geometry

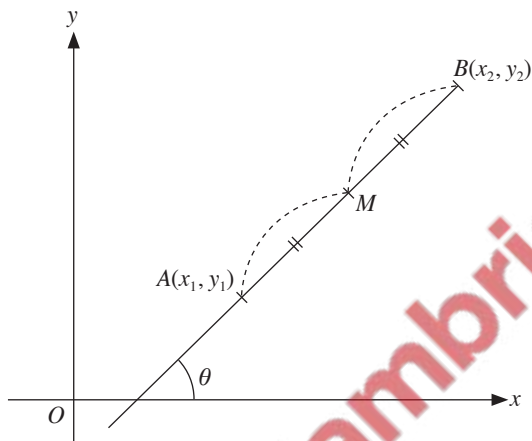

Distance between 2 Points

1. Length of $AB = \sqrt{(x_2 - x_1)^2 + (y_2 - y_1)^2}$

Midpoint of 2 Points

2. Midpoint of $AB = \left(\frac{x_1 + x_2}{2}, \frac{y_1 + y_2}{2} \right)$

Gradient of Line and Collinear Points

3. Gradient of $AB, m = \frac{y_2 - y_1}{x_2 - x_1} = \frac{y_1 - y_2}{x_1 - x_2} = \tan \theta$

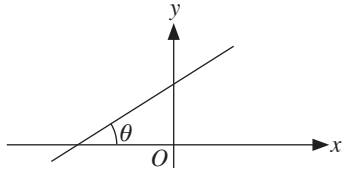
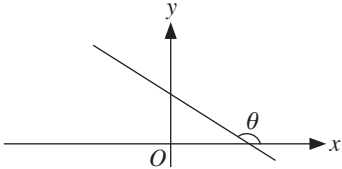
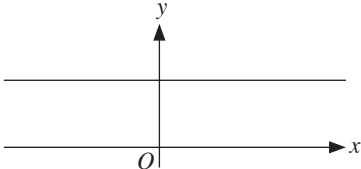
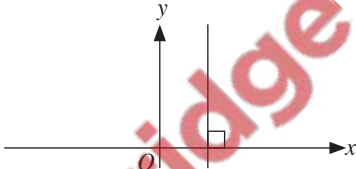
<p>4. $m > 0$ i.e. $0^\circ < \theta < 90^\circ$ (line slopes upwards)</p> 	<p>$m < 0$ i.e. $90^\circ < \theta < 180^\circ$ (line slopes downwards)</p> 
<p>$m = 0$ i.e. $\theta = 0^\circ$ (horizontal line)</p> 	<p>m is undefined i.e. $\theta = 90^\circ$ (vertical line)</p> 

5. If $A(x_1, y_1)$, $B(x_2, y_2)$ and $C(x_3, y_3)$ are collinear, then gradient of $AB =$ gradient of $BC =$ gradient of AC and area of $\triangle ABC = 0$.

Parallel and Perpendicular Lines

6. Given that two lines l_1 and l_2 have gradients m_1 and m_2 respectively,
- l_1 is parallel to l_2 if $m_1 = m_2$;
 - l_1 is perpendicular to l_2 if $m_1 m_2 = -1$.
7. The perpendicular bisector of a line AB is defined as a line passing through the midpoint of AB , cutting it into two equal halves and it is also perpendicular to AB .

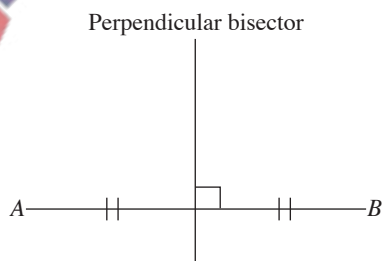

Equation of a Straight Line

8. Gradient form: $y = mx + c$, where m is the gradient and c is the y -intercept
 9. Intercept form: $\frac{x}{a} + \frac{y}{b} = 1$, where a and b are the intercepts the line makes on the x -axis and y -axis respectively
 10. General form: $Ax + By + C = 0$, where A , B and C are constants
-

Example 1

Find the equation of the perpendicular bisector of AB , where A is $(3, 10)$ and B is $(7, 2)$.

Solution

$$\begin{aligned}\text{Midpoint of } AB &= \left(\frac{3+7}{2}, \frac{10+2}{2} \right) && \text{(The perpendicular bisector of } AB \text{ passes} \\ &= (5, 6) && \text{through the midpoint of } AB.)\end{aligned}$$

$$\begin{aligned}\text{Gradient of } AB &= \frac{10-2}{3-7} \\ &= -2\end{aligned}$$

$$\text{Gradient of perpendicular bisector} = \frac{1}{2} \quad (m_1 m_2 = -1)$$

Equation of perpendicular bisector:

$$\begin{aligned}y - 6 &= \frac{1}{2}(x - 5) && \text{(To use } y - y_1 = m(x - x_1), \text{ we require the gradient and the} \\ & && \text{coordinates of a point on the line.)} \\ y &= \frac{1}{2}x + \frac{7}{2}\end{aligned}$$



Example 2

A line segment joins $P(5, 7)$ and $Q(x, y)$. The midpoint of the line segment is $(4, 2)$. Find the coordinates of Q and the equation of the perpendicular bisector of PQ .

Solution

$$\left(\frac{5+x}{2}, \frac{7+y}{2}\right) = (4, 2)$$

$$\frac{5+x}{2} = 4 \qquad \frac{7+y}{2} = 2$$

$$5+x = 8 \qquad 7+y = 4$$
$$x = 3 \qquad y = -3$$

$$\therefore Q(3, -3)$$

$$\text{Gradient of } PQ = \frac{7 - (-3)}{5 - 3}$$
$$= 5$$

$$\text{Gradient of perpendicular bisector} = -\frac{1}{5}$$

Equation of perpendicular bisector:

$$\frac{y-2}{x-4} = -\frac{1}{5}$$

$$5y - 10 = -x + 4$$

$$y = \frac{14}{5} - \frac{1}{5}x$$

Collinear Points

11.

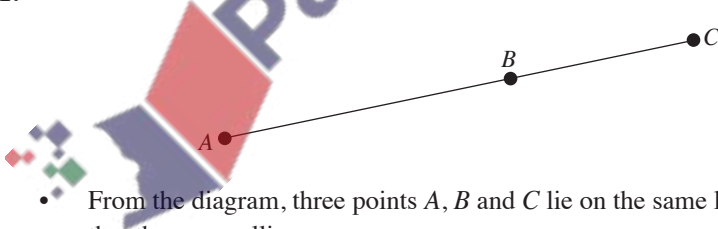

- From the diagram, three points A , B and C lie on the same line. We can say that they are collinear.
- To show that the points are collinear, determine 2 of the 3 gradients of the line segments AB , AC and BC . The gradients must be equal, i.e. $m_{AB} = m_{AC}$,
 $m_{AC} = m_{BC}$ or $m_{AB} = m_{BC}$.

Area of Polygons

12. If $A(x_1, y_1)$, $B(x_2, y_2)$, $C(x_3, y_3)$, ... , and $N(x_n, y_n)$ form a polygon, then

$$\begin{aligned} \text{Area of polygon} &= \frac{1}{2} \begin{vmatrix} x_1 & x_2 & x_3 & \dots & x_n & x_1 \\ y_1 & y_2 & y_3 & \dots & y_n & y_1 \end{vmatrix} \\ &= \frac{1}{2} (x_1y_2 + x_2y_3 + \dots + x_ny_1 - x_2y_1 - x_3y_2 - \dots - x_1y_n) \end{aligned}$$

13. If $A(x_1, y_1)$, $B(x_2, y_2)$ and $C(x_3, y_3)$ form a triangle ABC , then

$$\text{Area of } \triangle ABC = \frac{1}{2} \begin{vmatrix} x_1 & x_2 & x_3 & x_1 \\ y_1 & y_2 & y_3 & y_1 \end{vmatrix}$$

14. Vertices must be taken in a cyclic and anticlockwise order.

Example 3

Find the area of a triangle with coordinates $A(20, -1)$, $B(30, 0)$ and $C(10, 5)$.

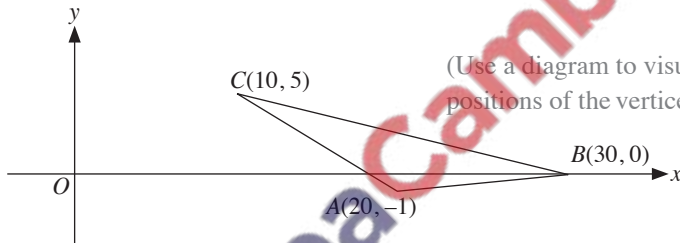

(Use a diagram to visualise the relative positions of the vertices of the triangle.)

Solution

$$\begin{aligned} \text{Area of triangle } ABC &= \frac{1}{2} \begin{vmatrix} 30 & 10 & 20 & 30 \\ 0 & 5 & -1 & 0 \end{vmatrix} \\ &= \frac{1}{2} |(150 - 10) - (100 - 30)| \\ &= \frac{1}{2} |(140 - 70)| \\ &= 35 \text{ units}^2 \end{aligned}$$

Example 4

A triangle has vertices $A(4, 0)$, $B(10, 4)$ and $C(9, 0)$. Given that $ABCD$ is a parallelogram, find

- (i) the coordinates of the point D ,
- (ii) the area of the parallelogram $ABCD$.

Solution

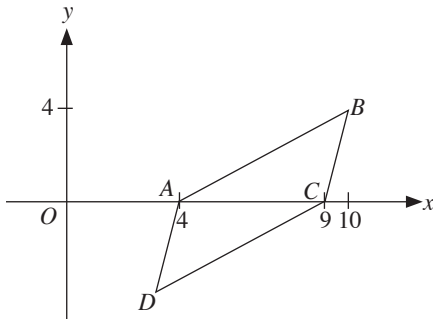

(Use a sketch to help you visualise the position of D .)

- (i) Let the coordinates of D be (x, y) .

Midpoint of BD = Midpoint of AC (The diagonals of a parallelogram bisect each other.)

$$\left(\frac{10+x}{2}, \frac{4+y}{2}\right) = \left(\frac{4+9}{2}, \frac{0+0}{2}\right)$$

$$\frac{10+x}{2} = \frac{4+9}{2}, \quad \frac{4+y}{2} = \frac{0+0}{2}$$

$$x = 3 \qquad y = -4$$

$$\therefore D(3, -4)$$

- (ii) Area of parallelogram $ABCD$

(Remember to take the vertices in a cyclic and anticlockwise order.)

$$= \frac{1}{2} \begin{vmatrix} 4 & 3 & 9 & 10 & 4 \\ 0 & -4 & 0 & 4 & 0 \end{vmatrix}$$

$$= \frac{1}{2} (-16 + 36 + 36 - 16)$$

$$= 20 \text{ units}^2$$

Example 5

$A(-1, -1)$, $B(-2, 2)$ and $C(2, 1)$ are three vertices of a parallelogram $ABCD$. Find the midpoint of AC . Hence, find the coordinates of D .

Solution

Let the coordinates of D be (h, k) .

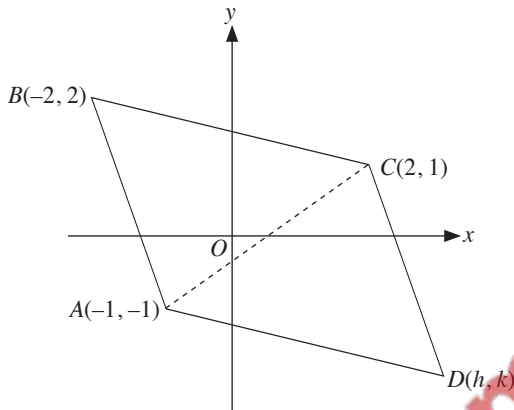

(Use a sketch to help you visualise the position of D .)

$$\begin{aligned}\text{Midpoint of } AC &= \left(\frac{-1+2}{2}, \frac{-1+1}{2} \right) \\ &= \left(\frac{1}{2}, 0 \right)\end{aligned}$$

Midpoint of AC = Midpoint of BD

$$\left(\frac{-2+h}{2}, \frac{2+k}{2} \right) = \left(\frac{1}{2}, 0 \right)$$

$$\frac{-2+h}{2} = \frac{1}{2}, \quad \frac{2+k}{2} = 0$$

$$h = 3 \quad k = -2$$

$$\therefore D(3, -2)$$

Ratio Theorem

15.

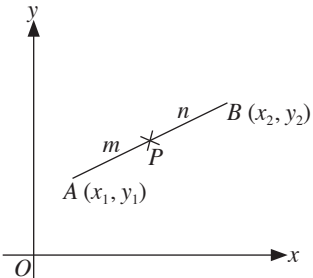
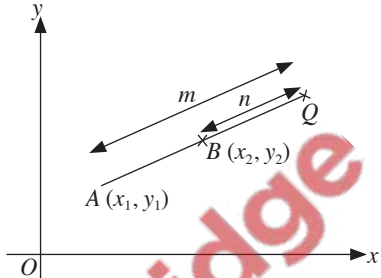
Internal point of division	External point of division
<p>Let the point P divide the line AB internally in the ratio $m : n$, then P is the point $\left(\frac{nx_1 + mx_2}{m + n}, \frac{ny_1 + my_2}{m + n}\right)$.</p> 	<p>Let the point Q divide the line AB externally in the ratio $m : n$, then Q is the point $\left(\frac{mx_2 - nx_1}{m - n}, \frac{my_2 - ny_1}{m - n}\right)$.</p> 

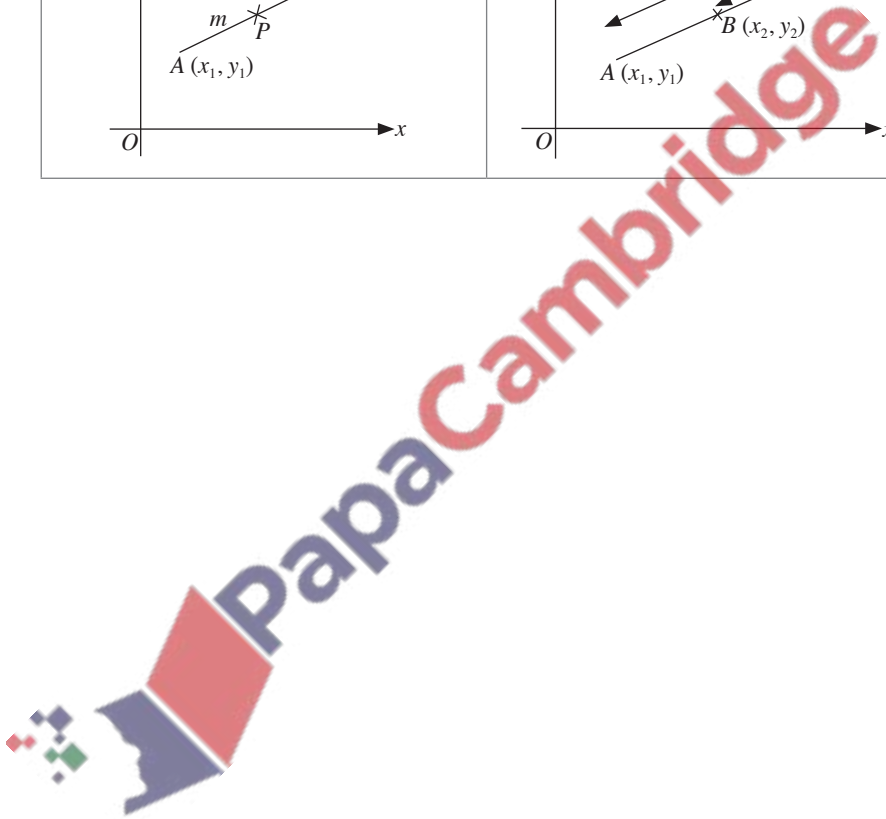

Example 6

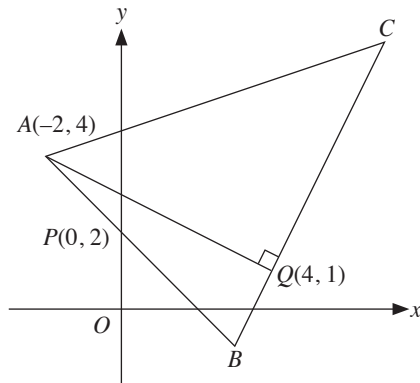

The diagram shows a triangle ABC in which A is the point $(-2, 4)$. The side AB cuts the y -axis at $P(0, 2)$. The point $Q(4, 1)$ lies on BC and the line AQ is perpendicular to BC . Find

- (i) the equation of BC ,
- (ii) the coordinates of B .

Given further that Q divides BC internally in the ratio $1 : 3$, find

- (iii) the coordinates of C ,
- (iv) the area of triangle ABC .

Solution

(i) Gradient of $AQ = \frac{4-1}{-2-4}$
 $= -\frac{1}{2}$

Gradient of $BC = 2$

Equation of BC : $y - 1 = 2(x - 4)$
 $y = 2x - 7 \quad (1)$

(To use $y - y_1 = m(x - x_1)$, we require the gradient and the coordinates of a point on the line.)

$$\begin{aligned} \text{(ii) Gradient of } AB &= \frac{4-2}{-2-0} \\ &= -1 \end{aligned}$$

Equation of AB : $y = -x + 2$ — (2) (We can use $y = mx + c$ because we know that the y -intercept is 2.)

Solving (1) and (2), (Since B lies on AB and BC , we solve the equations of these 2 lines simultaneously.)

$$x = 3$$

$$y = -1$$

$$\therefore B(3, -1)$$

(iii)

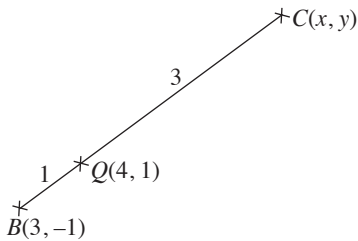

(Use a sketch to help you visualise the position of C .)

Let the coordinates of C be (x, y) .

Using Ratio Theorem,

$$\left(\frac{3(3) + 1(x)}{3 + 1}, \frac{3(-1) + 1(y)}{3 + 1} \right) = (4, 1)$$

$$\frac{9 + x}{4} = 4, \quad \frac{y - 3}{4} = 1$$

$$x = 7 \quad y = 7$$

$$\therefore C(7, 7)$$

(iv) Area of $\triangle ABC$

$$= \frac{1}{2} \begin{vmatrix} -2 & 3 & 7 & -2 \\ 4 & -1 & 7 & 4 \end{vmatrix}$$

(Remember to take the vertices in a cyclic and anticlockwise order.)

$$= \frac{1}{2} (2 + 21 + 28 - 12 + 7 + 14)$$

$$= 30 \text{ units}^2$$

UNIT 6

Further Coordinate Geometry

Equation of a Circle

1. Standard form

$$(x - a)^2 + (y - b)^2 = r^2$$

where (a, b) is the centre and r is the radius

2. General form

$$x^2 + y^2 + 2gx + 2fy + c = 0$$

where $(-g, -f)$ is the centre and $\sqrt{g^2 + f^2 - c}$ is the radius

Example 1

Find the equation of the circle with centre $(1, 2)$ and radius of 8.

Solution

Equation of circle:

$$(x - 1)^2 + (y - 2)^2 = 8^2$$

$$(x - 1)^2 + (y - 2)^2 = 64$$



Example 2

A circle has centre $(-1, 1)$ and passes through $(2, 5)$.

- (i) Find the equation of the circle.
(ii) Determine if $(3, 3)$ lies on the circumference of the circle.

Solution

- (i) Radius, $r = \sqrt{(2+1)^2 + (5-1)^2}$ (To find the equation of the circle, we need the radius and the coordinates of the centre.)
 $= 5$

$$\therefore \text{Equation of circle is } (x+1)^2 + (y-1)^2 = 25$$

$$x^2 + 2x + 1 + y^2 - 2y + 1 = 25$$

$$x^2 + y^2 + 2x - 2y - 23 = 0$$

- (ii) Substitute $x = 3, y = 3$ into $(x+1)^2 + (y-1)^2$:
 $(3+1)^2 + (3-1)^2 = 20$

$\therefore (3, 3)$ does not lie on the circle. (In fact, $(3, 3)$ lies inside the circle.)

Example 3

A circle has the equation $x^2 + y^2 - 10x + 6y + 9 = 0$.

Find the coordinates of the centre and radius of the circle.

Solution

$$x^2 + y^2 - 10x + 6y + 9 = 0$$

$$(x-5)^2 - 25 + (y+3)^2 - 9 + 9 = 0$$

$$(x-5)^2 + (y+3)^2 = 5^2$$

Coordinates of centre = $(5, -3)$, radius = 5

Example 4

Find the coordinates of the centre and the radius of a circle with the equation $x^2 + y^2 - 2x - 4y + 5 = 64$.

Solution

$$\begin{aligned}x^2 + y^2 - 2x - 4y + 5 &= 64 \\x^2 + y^2 - 2x - 4y - 59 &= 0\end{aligned}$$

Comparing this with $x^2 + y^2 + 2gx + 2fy + c = 0$

$$\begin{aligned}2g &= -2 & 2f &= -4 & c &= -59 \\g &= -1 & f &= -2\end{aligned}$$

Centre of circle $(-g, -f) = (1, 2)$

$$\begin{aligned}\text{Radius of circle} &= \sqrt{g^2 + f^2 - c} \\&= \sqrt{(-1)^2 + (-2)^2 + 59} \\&= 8\end{aligned}$$

Example 5

Find the radius and the coordinates of the centre of the circle $2x^2 + 2y^2 - 3x + 4y + 1 = 0$.

Solution

$$2x^2 + 2y^2 - 3x + 4y + 1 = 0$$

$$x^2 + y^2 - \frac{3}{2}x + 2y + \frac{1}{2} = 0$$

$$\left(x - \frac{3}{4}\right)^2 - \frac{9}{16} + (y + 1)^2 - 1 + \frac{1}{2} = 0$$

$$\left(x - \frac{3}{4}\right)^2 + (y + 1)^2 = \frac{17}{16}$$

$$\therefore \text{Radius} = \frac{\sqrt{17}}{4}, \text{ coordinates of centre} = \left(\frac{3}{4}, -1\right)$$

Example 6

Show that the line $4y = x - 3$ touches the circle $x^2 + y^2 - 4x - 8y + 3 = 0$.
Hence, find the coordinates of the point of contact.

Solution

$$4y = x - 3 \quad \text{--- (1)}$$

$$x^2 + y^2 - 4x - 8y + 3 = 0 \quad \text{--- (2)}$$

From (1),

$$y = \frac{x - 3}{4} \quad \text{--- (3)}$$

Substitute (3) into (2):

$$x^2 + \left(\frac{x - 3}{4}\right)^2 - 4x - 8\left(\frac{x - 3}{4}\right) + 3 = 0$$

$$x^2 + \frac{x^2 - 6x + 9}{16} - 4x - 2x + 6 + 3 = 0$$

$$16x^2 + x^2 - 6x + 9 - 64x - 32x + 96 + 48 = 0$$

$$17x^2 - 102x + 153 = 0$$

$$x^2 - 6x + 9 = 0$$

$$\begin{aligned} \text{Discriminant} &= (-6)^2 - 4(1)(9) \\ &= 0 \end{aligned}$$

\therefore The line is a tangent to the circle.

Solving $x^2 - 6x + 9 = 0$,

$$(x - 3)^2 = 0$$

$$x = 3$$

$$y = 0$$

\therefore Point of contact is $(3, 0)$



Further Graphs

3. Graphs of the form $y^2 = kx$, where k is a real number

(a) $k > 0$

(b) $k < 0$

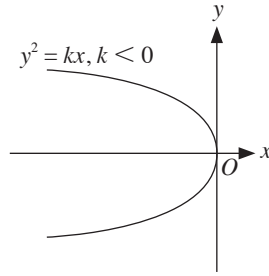
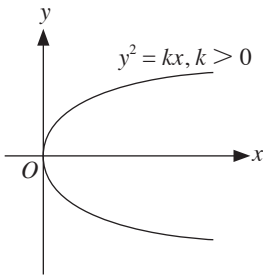

4. Graphs of $y = ax^n$

(a) n is even and $a > 0$

e.g. $y = 3x^2$

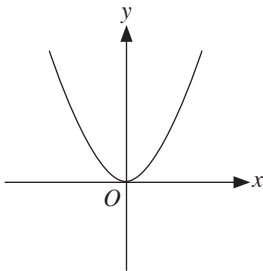

(b) n is even and $a < 0$

e.g. $y = -3x^2$

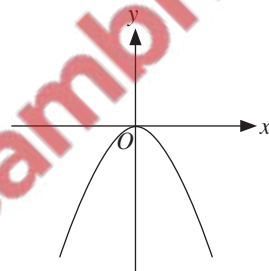

(c) n is odd and $a > 0$

e.g. $y = 2x^3$

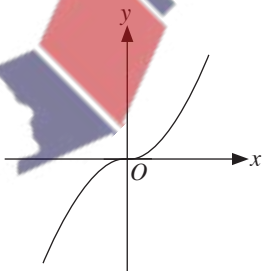

(d) n is odd and $a < 0$

e.g. $y = -2x^3$

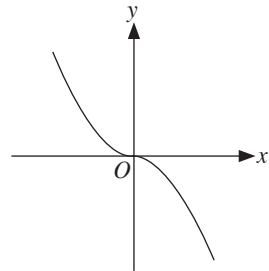

5. Graphs of $y = ax^{-n}$

(a) n is even and $a > 0$

e.g. $y = 3x^{-2}$

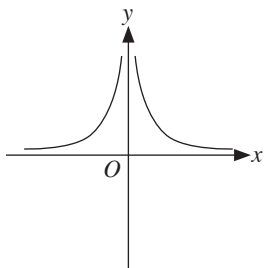

(b) n is even and $a < 0$

e.g. $y = -3x^{-2}$

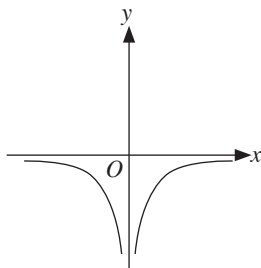

(c) n is odd and $a > 0$

e.g. $y = 3x^{-3}$

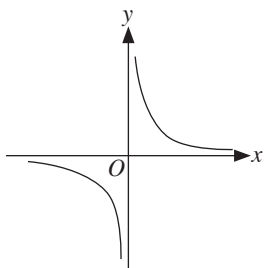

(d) n is odd and $a < 0$

e.g. $y = -3x^{-3}$

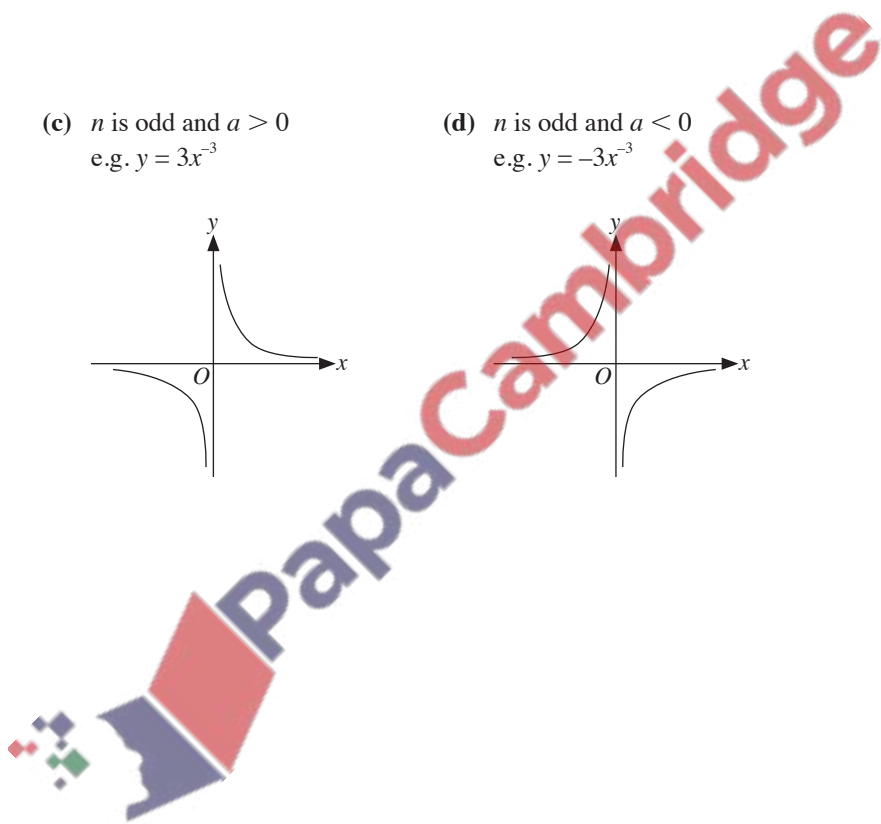
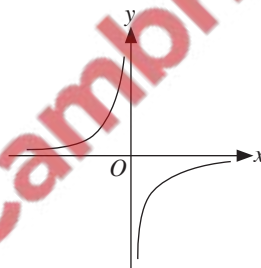

6. Graphs of $y = ax^{\frac{1}{n}}$

(a) n is even and $a > 0$

e.g. $y = 4x^{\frac{1}{6}}$

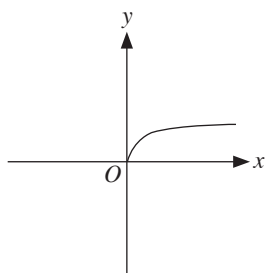

(b) n is even and $a < 0$

e.g. $y = -4x^{\frac{1}{6}}$

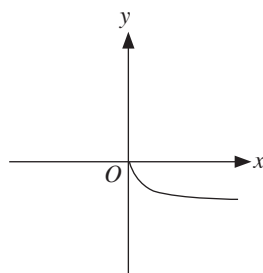

(c) n is odd and $a > 0$

e.g. $y = 3x^{\frac{1}{7}}$

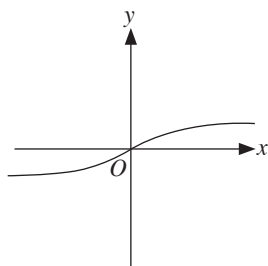

(d) n is odd and $a < 0$

e.g. $y = -3x^{\frac{1}{7}}$

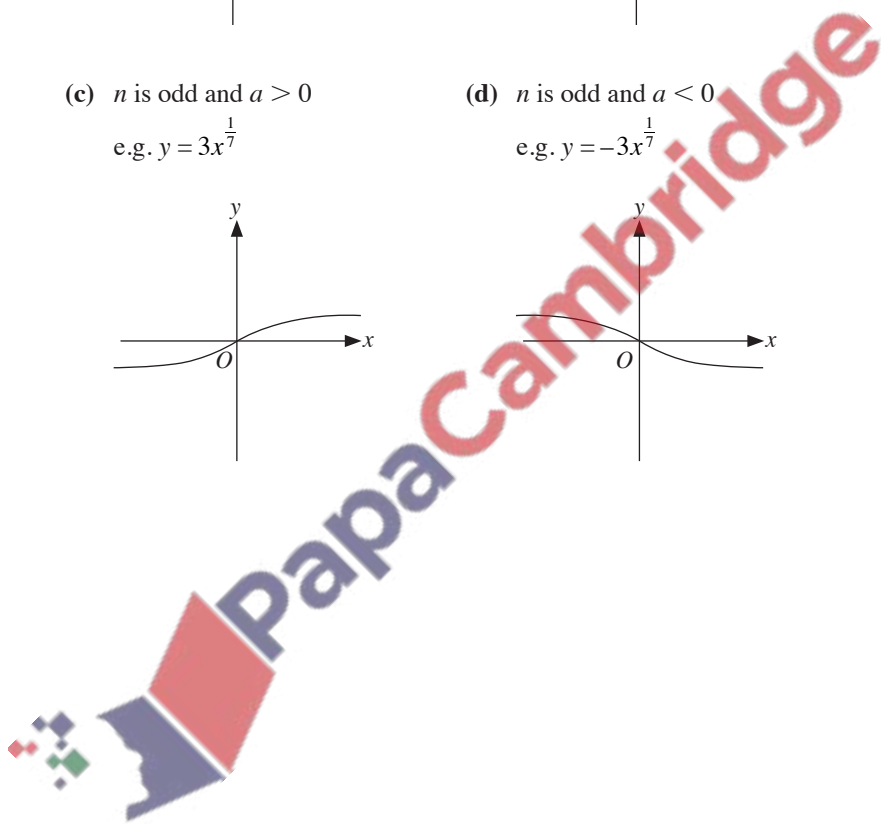
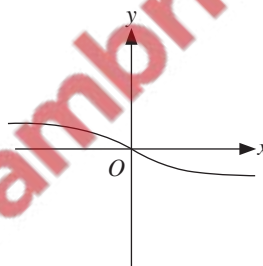

7. Graphs of $y = ax^{-\frac{1}{n}}$

(a) n is even and $a > 0$

e.g. $y = 4x^{-\frac{1}{10}}$

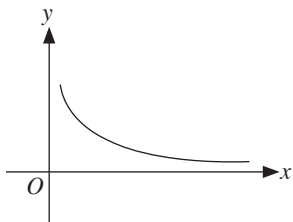

(b) n is even and $a < 0$

e.g. $y = -4x^{-\frac{1}{10}}$

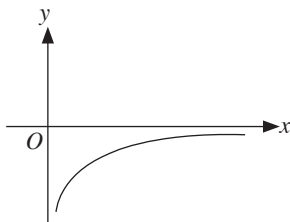

(c) n is odd and $a > 0$

e.g. $y = 0.5x^{-\frac{1}{7}}$

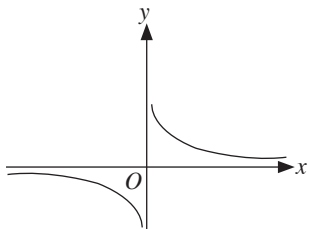

(d) n is odd and $a < 0$

e.g. $y = -0.5x^{-\frac{1}{7}}$

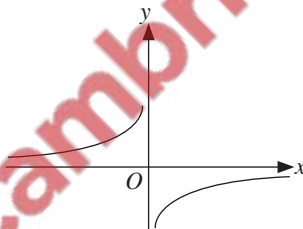

UNIT 7

Linear Law

(not included for NA)

The Linear Law

1.

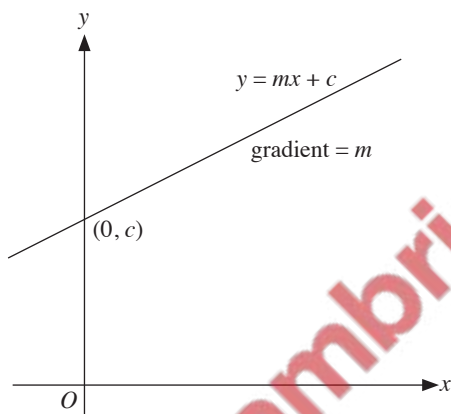

If the variables x and y are related by the equation $y = mx + c$, then a graph of the values of y plotted against their respective values of x is a straight line graph.

The straight line has a gradient m and it cuts the vertical axis at the point $(0, c)$.

2. Linear Law is used to reduce non-linear functions to the linear form $y = mx + c$.
3. To reduce confusion, we sometimes denote the horizontal axis as X and the vertical axis as Y , i.e. $Y = mX + c$.

4. Some of the common functions and their corresponding X and Y are shown in the table.

Function		X	Y
1.	$y = ax^n + b$	x^n	y
2.	$y = \frac{a}{x^n} + b$	$\frac{1}{x^n}$	y
3.	$\frac{1}{y} = ax^n + b$	x^n	$\frac{1}{y}$
4.	$y = a\sqrt[n]{x} + b$	$\sqrt[n]{x}$	y
5.	$y = a\sqrt{x} + \frac{b}{\sqrt{x}}$ i.e. $y\sqrt{x} = ax + b$	x	$y\sqrt{x}$
6.	$xy = \frac{a}{x} + bx$ i.e. $x^2y = bx^2 + a$ or $y = \frac{a}{x^2} + b$	x^2 $\frac{1}{x^2}$	x^2y y
7.	$x = bxy + ay$ i.e. $\frac{x}{y} = bx + a$ or $\frac{1}{y} = \frac{a}{x} + b$	x $\frac{1}{x}$	$\frac{x}{y}$ $\frac{1}{y}$
8.	$\frac{a}{x} + \frac{b}{y} = n$ i.e. $\frac{1}{y} = \left(-\frac{a}{b}\right)\frac{1}{x} + \frac{n}{b}$ or $ay + bx = nxy$ i.e. $y = \left(\frac{a}{n}\right)\frac{y}{x} + \frac{b}{n}$	$\frac{1}{x}$ $\frac{y}{x}$	$\frac{1}{y}$ y
9.	$y = ax^2 + bx + n$ i.e. $\frac{y-n}{x} = ax + b$	x	$\frac{y-n}{x}$

Function	X	Y
10. $y = a^2x^2 + 2abx + b^2$ i.e. $\sqrt{y} = ax + b$ or $\sqrt{y} = -ax - b$	x x	\sqrt{y} \sqrt{y}
11. $y = \frac{a}{x-b}$ i.e. $\frac{1}{y} = \frac{1}{a}x - \frac{b}{a}$	x	$\frac{1}{y}$
12. $y = ax^b$ i.e. $\lg y = b \lg x + \lg a$ or $\ln y = b \ln x + \ln a$	$\lg x$ $\ln x$	$\lg y$ $\ln y$
13. $y = ax^b + n$ i.e. $\lg(y-n) = b \lg x + \lg a$	$\lg x$	$\lg(y-n)$
14. $y = ab^x$ i.e. $\lg y = x \lg b + \lg a$	x	$\lg y$
15. $y^n = \frac{b^x}{a}$ i.e. $\lg y = x \left(\frac{\lg b}{n} \right) - \frac{\lg a}{n}$	x	$\lg y$
16. $ya^x = b + n$ i.e. $\lg y = (-\lg a)x + \lg(b+n)$	x	$\lg y$
17. $y^b = 10^{2x+a}$ i.e. $\lg y = \frac{2}{b}x + \frac{a}{b}$	x	$\lg y$
18. $y^b = e^{2x+a}$ i.e. $\ln y = \frac{2}{b}x + \frac{a}{b}$	x	$\ln y$



Example 1

The variables x and y are related in such a way that when $y - 3x$ is plotted against x^2 , a straight line passing through $(2, 1)$ and $(5, 7)$ is obtained. Find

- (i) y in terms of x ,
- (ii) the values of x when $y = 62$.

Solution

With reference to the sketch graph and using Y to represent $y - 3x$ and X to represent x^2 ,

the equation of the straight line is $\frac{Y - 1}{X - 2} = \frac{7 - 1}{5 - 2}$.

i.e. $Y - 1 = 2(X - 2)$

$$Y = 2X - 3$$

(i) $y - 3x = 2x^2 - 3$
 $y = 2x^2 + 3x - 3$

(ii) When $y = 62$,
 $2x^2 + 3x - 3 = 62$
 $2x^2 + 3x - 65 = 0$
 $(x - 5)(2x + 13) = 0$
 $x = 5$ or $x = -\frac{13}{2}$

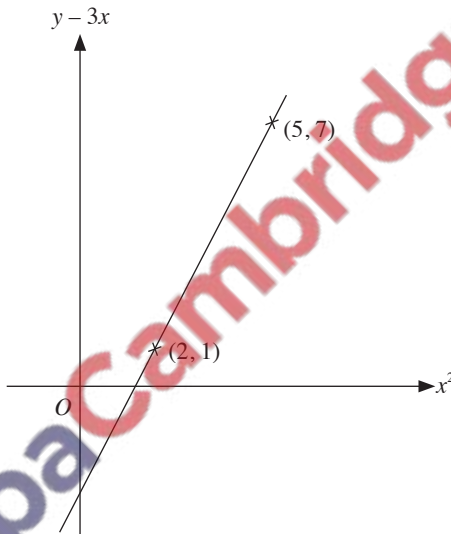

Example 2

It is known that x and y are related by the formula $xy = a + bx$, where a and b are constants.

x	2	4	6	8	10
y	38	21.3	15.8	13.1	11.5

Express this equation in a form suitable for drawing a straight line graph. Draw this graph for the given data and use it to estimate the value of a and of b .

Solution

Since $xy = a + bx$,

$$y = \frac{a}{x} + b.$$

Plot y against $\frac{1}{x}$, gradient = a , vertical-axis intercept = b .

x	2	4	6	8	10
y	38	21.3	15.8	13.1	11.5
$\frac{1}{x}$	0.50	0.25	0.17	0.13	0.10

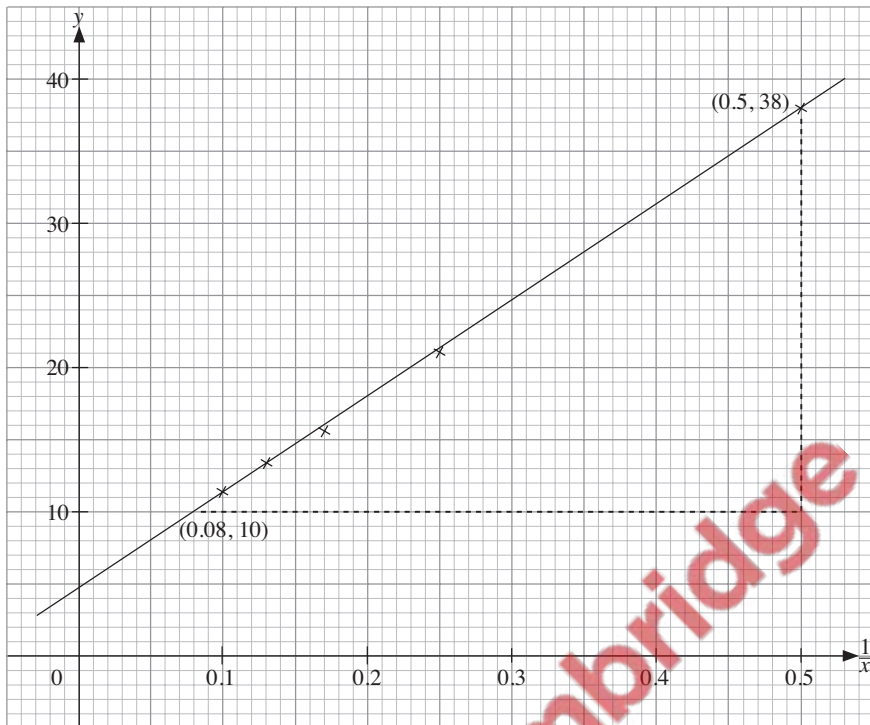

From the graph, vertical-axis intercept = 4.8

$$\text{Using } (0.08, 10) \text{ and } (0.5, 38), \text{ gradient} = \frac{38 - 10}{0.5 - 0.08}$$

$$= 66.7 \text{ (to 3 s.f.)}$$

$$\therefore a = 66.7, b = 4.8$$

Example 3

The volume (V) of a container and the height of the container (x) are connected by an equation of the form $V = hk^x$, where h and k are constants.

x	1	2	3	4	5
V	12.6	25.1	50.1	90.0	199.5

- (a) Express $V = hk^x$ in a form suitable for drawing a straight line graph.
(b) Plot this straight line graph and use it to estimate the value of h and of k .

Solution

- (a) $V = hk^x$
 $\lg V = (\lg k)x + \lg h$
 $Y = mX + c$
Gradient = $\lg k$
Y-intercept = $\lg h$

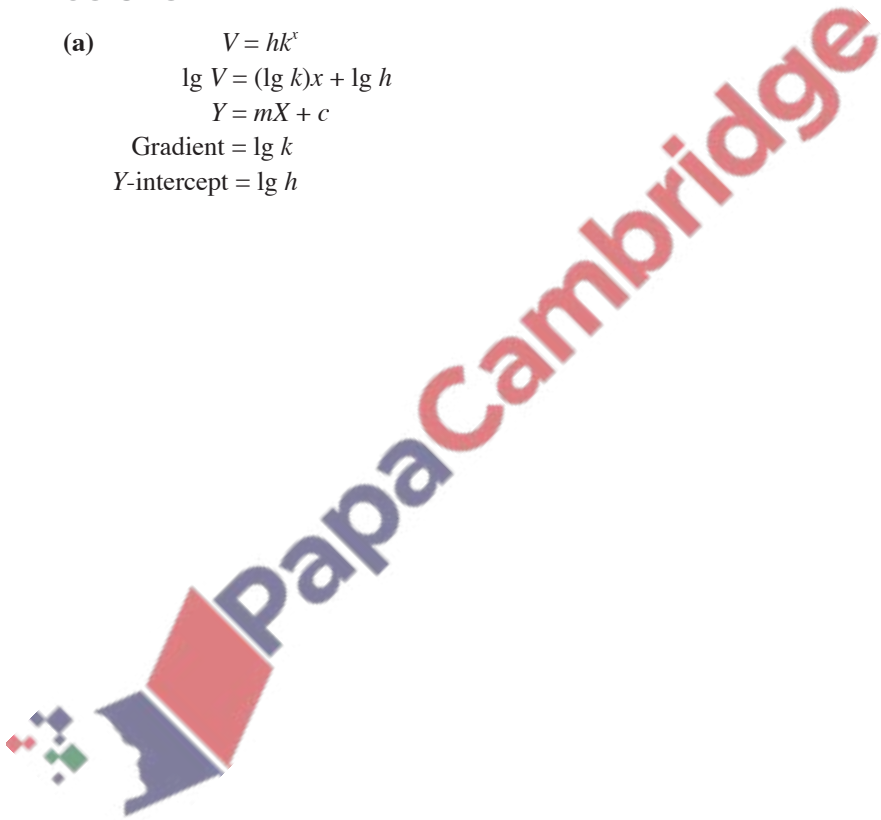

(b)

x	1	2	3	4	5
V	12.6	25.1	50.1	90.0	199.5
$\lg V$	1.10	1.40	1.70	1.95	2.30

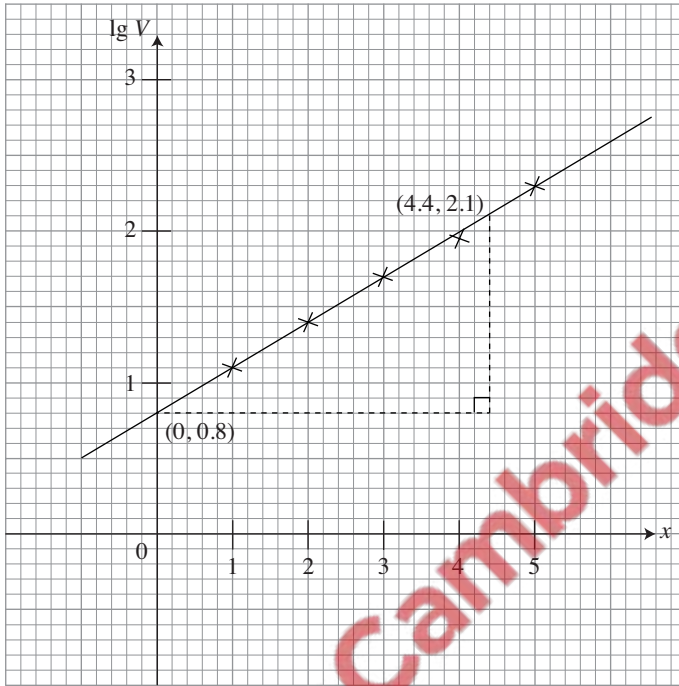

From the graph,

vertical-axis intercept = 0.8

$$\lg h = 0.8$$

$$h = 6.31 \text{ (to 3 s.f.)}$$

Using (0, 0.8) and (4.4, 2.1),

$$\text{gradient} = \frac{2.1 - 0.8}{4.4 - 0}$$

$$= 0.295 \text{ (to 3 s.f.)}$$

$$\lg k = 0.295$$

$$k = 1.97 \text{ (to 3 s.f.)}$$

UNIT 8

Trigonometric Functions and Equations

Basic Trigonometric Ratios

1.

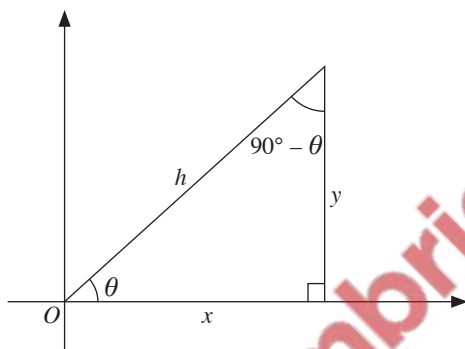

- $\sin \theta = \frac{y}{h}$
- $\cos \theta = \frac{x}{h}$
- $\tan \theta = \frac{y}{x}$
- $\operatorname{cosec} \theta = \frac{1}{\sin \theta} = \frac{h}{y}$
- $\sec \theta = \frac{1}{\cos \theta} = \frac{h}{x}$
- $\cot \theta = \frac{1}{\tan \theta} = \frac{x}{y}$

Complementary Angles

- 2.
- $\sin (90^\circ - \theta) = \cos \theta$
 - $\tan (90^\circ - \theta) = \cot \theta$
 - $\sec (90^\circ - \theta) = \operatorname{cosec} \theta$
 - $\cos (90^\circ - \theta) = \sin \theta$
 - $\cot (90^\circ - \theta) = \tan \theta$
 - $\operatorname{cosec} (90^\circ - \theta) = \sec \theta$

Basic Angle (or Reference Angle)

3. The basic angle, α , is the acute angle between a rotating radius about the origin and the x -axis.

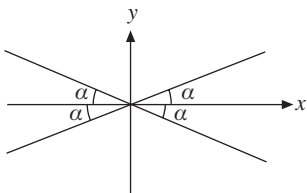

- $\sin(-\theta) = -\sin \theta$
- $\cos(-\theta) = \cos \theta$
- $\tan(-\theta) = -\tan \theta$

Signs of Trigonometric Ratios in the Four Quadrants

4.

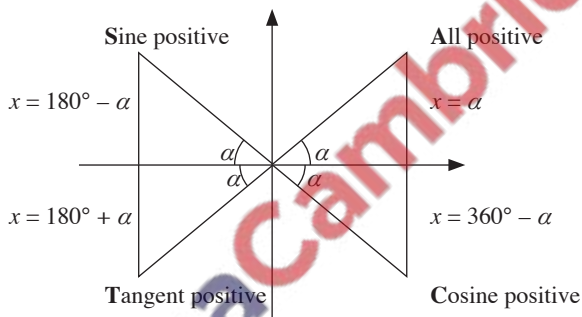

Example 1

Given that $\cos \theta = -\frac{4}{5}$ and that $180^\circ < \theta < 270^\circ$, find the value of $\sin \theta$ and $\tan \theta$.

Solution

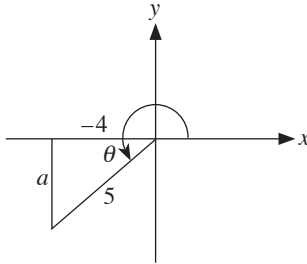

θ lies in the 3rd quadrant.

$$(-4)^2 + a^2 = 5^2$$

$$a^2 = 25 - 16$$

$$= 9$$

$$a = -3 \quad (\text{Since } a \text{ lies in the negative } y\text{-axis, } a < 0.)$$

$$\sin \theta = -\frac{3}{5}$$

$$\tan \theta = \frac{3}{4}$$



Example 2

Given that $\sec \alpha = \frac{17}{15}$ and that α is an acute angle, find the value of each of the following.

- (i) $\sin \alpha$
- (ii) $\tan (90^\circ - \alpha)$
- (iii) $\cos (180^\circ - \alpha)$

Solution

$\sec \alpha = \frac{17}{15}$ i.e. $\cos \alpha = \frac{15}{17}$ (Recall that $\sec x = \frac{1}{\cos x}$.)

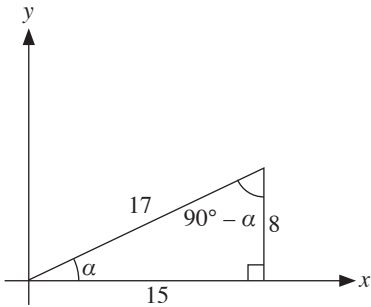

(Use Pythagoras' Theorem to find the length of the side opposite α .)

(i) $\sin \alpha = \frac{8}{17}$

(ii) $\tan (90^\circ - \alpha) = \frac{15}{8}$

(iii) $\cos (180^\circ - \alpha) = -\cos \alpha$
 $= -\frac{15}{17}$

Example 3

Given that $270^\circ \leq \beta < 360^\circ$ and $\sin \beta = -\frac{4}{5}$, find the value of each of the following without using a calculator.

- (i) $\cos \beta$
- (ii) $\tan \beta$

Solution

β lies in the 4th quadrant.

$$4^2 + a^2 = 5^2$$

$$a^2 = 25 - 16$$

$$= 9$$

$$a = 3 \quad (\text{Since } a \text{ lies in the positive } x\text{-axis, } a > 0.)$$

(i) $\cos \beta = \frac{3}{5}$

(ii) $\tan \beta = -\frac{4}{3}$

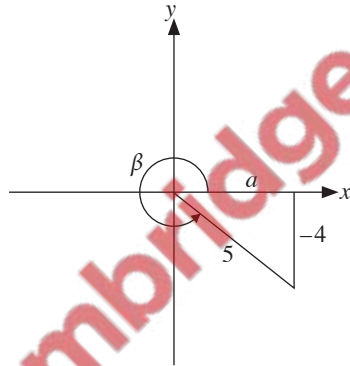

Trigonometric Ratios of Special Angles

5.

θ	$\sin \theta$	$\cos \theta$	$\tan \theta$
0°	0	1	0
$30^\circ = \frac{\pi}{6}$	$\frac{1}{2}$	$\frac{\sqrt{3}}{2}$	$\frac{\sqrt{3}}{3}$
$45^\circ = \frac{\pi}{4}$	$\frac{\sqrt{2}}{2}$	$\frac{\sqrt{2}}{2}$	1
$60^\circ = \frac{\pi}{3}$	$\frac{\sqrt{3}}{2}$	$\frac{1}{2}$	$\sqrt{3}$
$90^\circ = \frac{\pi}{2}$	1	0	Undefined
$180^\circ = \pi$	0	-1	0
$270^\circ = \frac{3\pi}{2}$	-1	0	Undefined
$360^\circ = 2\pi$	0	1	0



Example 4

Find all the angles between 0° and 360° inclusive which satisfy each of the following equations.

(i) $5 \sin^2 x - 6 \sin x \cos x = 0$

(ii) $1 + 2 \sin \left(\frac{3y}{2} + 15^\circ \right) = 0$

Solution

- (i) $5 \sin^2 x - 6 \sin x \cos x = 0$ (Do not make the mistake of dividing throughout by $\sin x$ ($5 \sin x - 6 \cos x = 0$) by $\sin x$, as you will then be short of answers.)

$$5 \sin x - 6 \cos x = 0$$

$$5 \sin x = 6 \cos x$$

$$\sin x = 0$$

$$x = 0^\circ, 180^\circ, 360^\circ$$

$$\tan x = \frac{6}{5} \quad (\text{Recall that } \tan x = \frac{\sin x}{\cos x}.)$$

$$\alpha = 50.19^\circ \text{ (to 2 d.p.)}$$

$$x = 50.2^\circ, 230.2^\circ \text{ (to 1 d.p.)}$$

$$\therefore x = 0^\circ, 50.2^\circ, 180^\circ, 230.2^\circ, 360^\circ$$

(ii) $1 + 2 \sin \left(\frac{3y}{2} + 15^\circ \right) = 0$

$$\sin \left(\frac{3y}{2} + 15^\circ \right) = -\frac{1}{2}$$

$$\alpha = 30^\circ$$

$$\frac{3y}{2} + 15^\circ = 210^\circ, 330^\circ \quad (\text{The required angles are in the 3}^{\text{rd}} \text{ and 4}^{\text{th}} \text{ quadrants.})$$

$$\frac{3y}{2} = 195^\circ, 315^\circ$$

$$\therefore y = 130^\circ, 210^\circ$$

Graphs of Trigonometric Functions

6. $y = a \sin bx$

- amplitude = a
- period = $\frac{360^\circ}{b}$

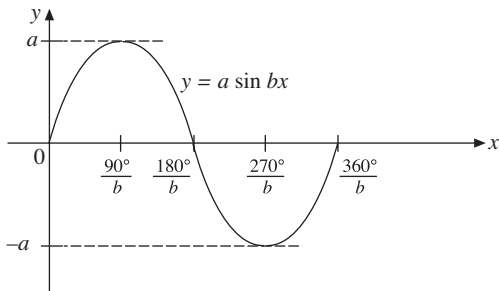

7. $y = a \cos bx$

- amplitude = a
- period = $\frac{360^\circ}{b}$

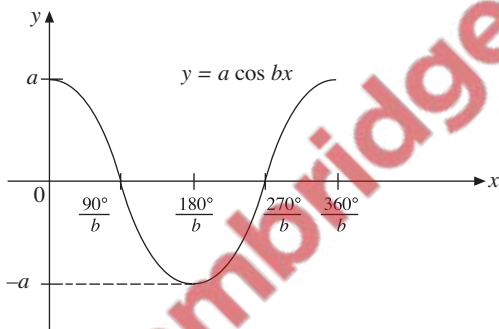

8. $y = a \tan bx$

- period = $\frac{180^\circ}{b}$

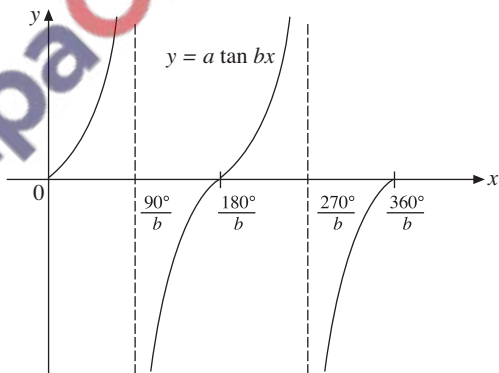

9. To sketch the graphs of $y = a \sin bx + c$ or $y = a \cos bx + c$ or $y = a \tan bx + c$:

Step 1: Draw the graph of $y = a \sin bx$ or $y = a \cos bx$ or $y = a \tan bx$.

Step 2: If $c > 0$, shift the graph up by c units.

If $c < 0$, shift the graph down by $|c|$ units.

Example 5

Sketch the graph of $y = 3 \sin 2x - 1$ in the domain $0^\circ \leq x \leq 180^\circ$.

Solution

First, sketch $y = 3 \sin 2x$.

It has an amplitude of 3 and period of 180° .

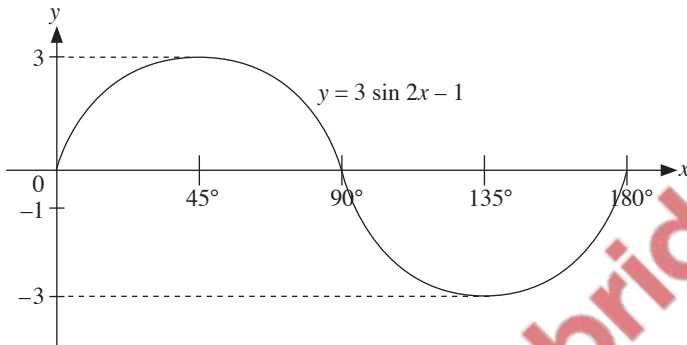

Next we shift the graph down by 1 unit.

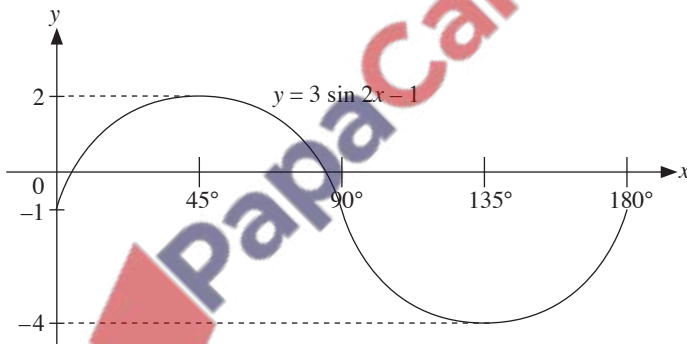

Example 6

Sketch the graph of $y = |\tan x| + 1$ for $0^\circ \leq x \leq 360^\circ$.

Solution

First, sketch $y = |\tan x|$.

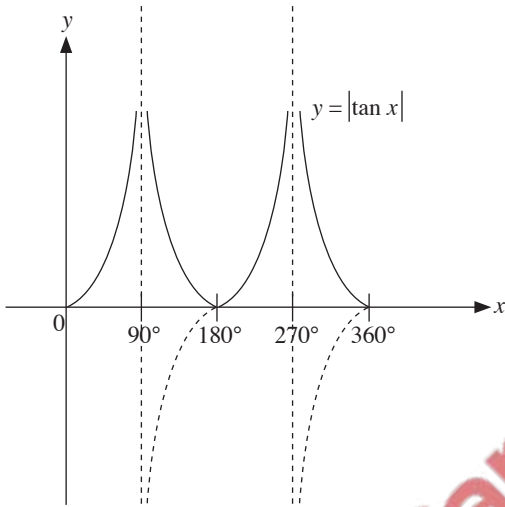

Next, shift the graph up by 1 unit.

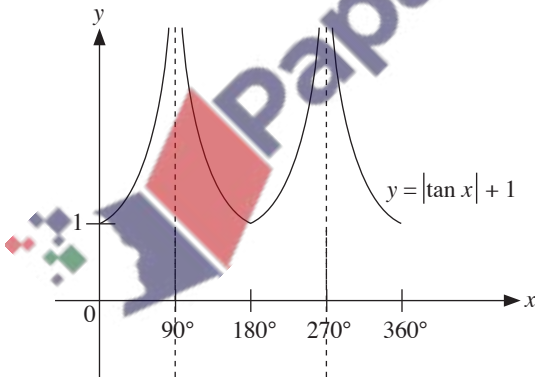

Example 7

Sketch on the same diagram, for $0 \leq x \leq 2\pi$, the graphs of

(i) $y = 1 + 4 \sin x$,

(ii) $y = 2 \cos x$.

Hence, deduce the number of roots of the equation $2 \cos x = 1 + 4 \sin x$ for $0 \leq x \leq 2\pi$.

Solution

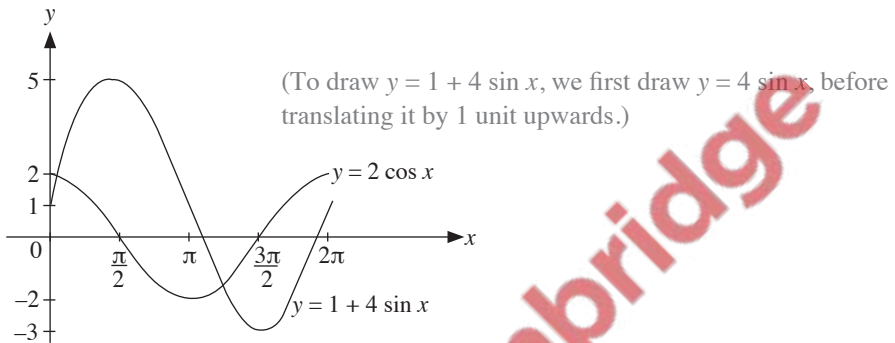

From the graph, there are 2 roots. (The question is asking for the number of intersection points between the graphs.)

Fundamental Identities

10.

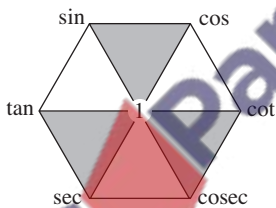

11. $\tan \theta = \frac{\sin \theta}{\cos \theta}$

12. $\cot \theta = \frac{\cos \theta}{\sin \theta}$

13. $\sec \theta = \frac{1}{\cos \theta}$

14. $\operatorname{cosec} \theta = \frac{1}{\sin \theta}$

UNIT 9

Trigonometric Identities and Formulae

Fundamental Identities

1. $\sin^2 A + \cos^2 A = 1$
2. $\tan^2 A + 1 = \sec^2 A$
3. $\cot^2 A + 1 = \operatorname{cosec}^2 A$

Example 1

Prove that $\frac{1 + \sin x}{\sin x \cos x} = \tan x + \cot x + \sec x$.

Solution

$$\begin{aligned}\text{RHS} &= \tan x + \cot x + \sec x \\ &= \frac{\sin x}{\cos x} + \frac{\cos x}{\sin x} + \frac{1}{\cos x} \\ &= \frac{\sin^2 x + \cos^2 x + \sin x}{\sin x \cos x} \quad (\text{Use the identity } \sin^2 x + \cos^2 x = 1.) \\ &= \frac{1 + \sin x}{\sin x \cos x} = \text{LHS (proven)}\end{aligned}$$

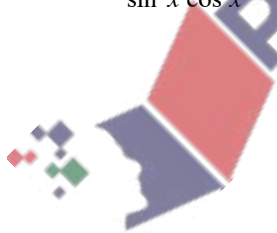

Example 2

Show that $\frac{1}{1 + \cos \theta} + \frac{1}{1 - \cos \theta} = 2 \operatorname{cosec}^2 \theta$.

Solution

$$\begin{aligned} \text{LHS} &= \frac{1}{1 + \cos \theta} + \frac{1}{1 - \cos \theta} \\ &= \frac{1 - \cos \theta + 1 + \cos \theta}{1 - \cos^2 \theta} \\ &= \frac{2}{\sin^2 \theta} \quad (\text{Use the identity } \sin^2 \theta + \cos^2 \theta = 1.) \\ &= 2 \operatorname{cosec}^2 \theta = \text{RHS (proven)} \quad (\text{Recall that } \operatorname{cosec} \theta = \frac{1}{\sin \theta}.) \end{aligned}$$

Example 3

Prove that $\sec^4 \theta - \sec^2 \theta = \tan^2 \theta + \tan^4 \theta$.

Solution

$$\begin{aligned} \text{LHS} &= \sec^4 \theta - \sec^2 \theta \\ &= \sec^2 \theta (\sec^2 \theta - 1) \\ &= (1 + \tan^2 \theta)(\tan^2 \theta) \quad (\text{Use the identity } \tan^2 \theta + 1 = \sec^2 \theta.) \\ &= \tan^2 \theta + \tan^4 \theta = \text{RHS (proven)} \end{aligned}$$



Example 4

Find all the angles between 0° and 360° inclusive which satisfy the equation
 $3 \tan^2 y + 5 = 7 \sec y$.

Solution

$$\begin{aligned}3 \tan^2 y + 5 &= 7 \sec y \\3(\sec^2 y - 1) + 5 &= 7 \sec y \quad (\text{Use } \tan^2 y + 1 = \sec^2 y \text{ to obtain a} \\3 \sec^2 y - 7 \sec y + 2 &= 0 \quad \text{quadratic equation in } \sec y.) \\(3 \sec y - 1)(\sec y - 2) &= 0 \\3 \sec y - 1 &= 0 \quad \text{or} \quad \sec y - 2 = 0 \\ \sec y &= \frac{1}{3} \quad \quad \quad \sec y = 2 \\ \cos y &= 3 \text{ (no solution)} \quad \quad \quad \cos y = \frac{1}{2} \\ & \quad \quad \quad \alpha = 60^\circ \\ & \quad \quad \quad \therefore y = 60^\circ, 300^\circ\end{aligned}$$

Compound Angle Formulae

- $\sin(A \pm B) = \sin A \cos B \pm \cos A \sin B$
- $\cos(A \pm B) = \cos A \cos B \mp \sin A \sin B$
- $\tan(A \pm B) = \frac{\tan A \pm \tan B}{1 \mp \tan A \tan B}$



Example 5

Find all the angles between 0° and 360° which satisfy the equation

$$5 \sin (x + 60^\circ) = \cos (x - 30^\circ).$$

Solution

$$5 \sin (x + 60^\circ) = \cos (x - 30^\circ)$$

$$5[\sin x \cos 60^\circ + \cos x \sin 60^\circ] = \cos x \cos 30^\circ + \sin x \sin 30^\circ$$

$$5\left[\frac{1}{2}\sin x + \frac{\sqrt{3}}{2}\cos x\right] = \frac{\sqrt{3}}{2}\cos x + \frac{1}{2}\sin x$$

$$5 \sin x + 5\sqrt{3} \cos x = \sqrt{3} \cos x + \sin x$$

$$4 \sin x = -4\sqrt{3} \cos x$$

$$\tan x = -\sqrt{3} \quad (\text{Recall that } \tan x = \frac{\sin x}{\cos x}.)$$

$$\alpha = 60^\circ$$

$$\therefore x = 120^\circ, 300^\circ \quad (x \text{ lies in the } 2^{\text{nd}} \text{ and } 4^{\text{th}} \text{ quadrants.})$$

Special Identities

- $\sin (\theta + 2n\pi) = \sin \theta$, where n is an integer
- $\cos (\theta + 2n\pi) = \cos \theta$, where n is an integer
- $\tan (\theta + 2n\pi) = \tan \theta$, where n is an integer
- $\sin (90^\circ \pm \theta) = \cos \theta$
- $\cos (90^\circ \pm \theta) = \mp \sin \theta$
- $\tan (90^\circ \pm \theta) = \mp \cot \theta$
- $\sin (180^\circ \pm \theta) = \mp \sin \theta$
- $\cos (180^\circ \pm \theta) = -\cos \theta$
- $\tan (180^\circ \pm \theta) = \pm \tan \theta$

Double Angle Formulae

16. $\sin 2A = 2 \sin A \cos A$

17. $\cos 2A = \cos^2 A - \sin^2 A$
 $= 2 \cos^2 A - 1$
 $= 1 - 2 \sin^2 A$

18. $\tan 2A = \frac{2 \tan A}{1 - \tan^2 A}$

Example 6

Given that $\tan \theta = -\frac{4}{3}$ and $270^\circ < \theta < 360^\circ$, find the value of

- (i) $\cos(-\theta)$,
- (ii) $\cos(90^\circ - \theta)$,
- (iii) $\sin(180^\circ + \theta)$,
- (iv) $\sin 2\theta$.

Solution

(i) $\cos(-\theta) = \cos \theta$
 $= \frac{3}{5}$

(ii) $\cos(90^\circ - \theta) = \sin \theta$
 $= -\frac{4}{5}$

(iii) $\sin(180^\circ + \theta) = -\sin \theta$
 $= \frac{4}{5}$

(iv) $\sin 2\theta = 2 \sin \theta \cos \theta$
 $= 2 \left(-\frac{4}{5}\right) \left(\frac{3}{5}\right)$
 $= -\frac{24}{25}$

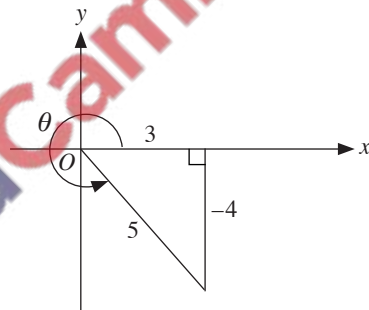

Example 7

Given that $\cos 2x = \frac{127}{162}$ and $270^\circ \leq 2x \leq 360^\circ$, find the value of

- (i) $\cos x$,
- (ii) $\sin x$.

Solution

- (i) Since $270^\circ \leq 2x \leq 360^\circ$, then $135^\circ \leq x \leq 180^\circ$.
 $\therefore x$ lies in the 2nd quadrant.

$$\cos 2x = \frac{127}{162}$$

$$2 \cos^2 x - 1 = \frac{127}{162}$$

$$2 \cos^2 x = \frac{289}{162}$$

$$\cos^2 x = \frac{289}{324}$$

$$\cos x = \pm \sqrt{\frac{289}{324}}$$

$$= \pm \frac{17}{18}$$

$$\therefore \cos x = -\frac{17}{18} \quad (\cos x < 0 \text{ since } x \text{ lies in the 2}^{\text{nd}} \text{ quadrant.})$$

- (ii)

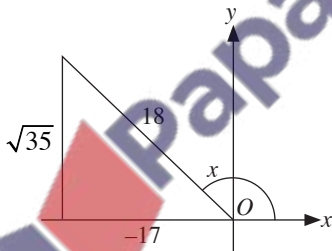

$$\sin x = \frac{\sqrt{35}}{18}$$

Half Angle Formulae

Replace A with $\frac{A}{2}$ in the Double Angle Formulae.

$$19. \sin A = 2 \sin \frac{A}{2} \cos \frac{A}{2}$$

$$20. \cos A = \cos^2 \frac{A}{2} - \sin^2 \frac{A}{2}$$
$$= 2 \cos^2 \frac{A}{2} - 1$$
$$= 1 - 2 \sin^2 \frac{A}{2}$$

$$21. \tan A = \frac{2 \tan \frac{A}{2}}{1 - \tan^2 \frac{A}{2}}$$

R-Formulae

$$22. a \sin \theta + b \cos \theta = R \sin (\theta + \alpha)$$

$$23. a \sin \theta - b \cos \theta = R \sin (\theta - \alpha)$$

$$24. a \cos \theta + b \sin \theta = R \cos (\theta - \alpha)$$

$$25. a \cos \theta - b \sin \theta = R \cos (\theta + \alpha)$$

where $R = \sqrt{a^2 + b^2}$ and $\tan \alpha = \frac{b}{a}$

26. For the expression $a \sin \theta \pm b \cos \theta$ or $a \cos \theta \pm b \sin \theta$,

- Maximum value = R
- Minimum value = $-R$

Example 8

Using the R -formula, find the maximum and minimum values of $6 \sin x - 5 \cos x$ for values of x , where $0^\circ < x < 360^\circ$.

Solution

$$6 \sin x - 5 \cos x = R \sin(x - \alpha)$$

$$R = \sqrt{6^2 + 5^2} = \sqrt{61}$$

$$\alpha = \tan^{-1} \left(\frac{5}{6} \right)$$

$$= 39.8^\circ$$

$$\therefore 6 \sin x - 5 \cos x = \sqrt{61} \sin(x - 39.8^\circ)$$

$$\text{Minimum value} = -\sqrt{61} \quad (\text{when } \sin(x - 39.8^\circ) = -1)$$

$$\text{Maximum value} = \sqrt{61} \quad (\text{when } \sin(x - 39.8^\circ) = 1)$$

Example 9

Solve $3 \sin 2x + 2 \sin x = 0$ for $0^\circ \leq x \leq 360^\circ$.

Solution

$$3 \sin 2x + 2 \sin x = 0$$

$$3(2 \sin x \cos x) + 2 \sin x = 0$$

$$3 \sin x \cos x + \sin x = 0$$

$$\sin x (3 \cos x + 1) = 0$$

$$\sin x = 0$$

or

$$3 \cos x + 1 = 0$$

$$x = 0^\circ, 180^\circ, 360^\circ$$

$$\cos x = -\frac{1}{3}$$

$$\alpha = 70.53^\circ$$

$$x = 109.5^\circ, 250.5^\circ \quad (\text{The required angles are in the 2}^{\text{nd}} \text{ and 4}^{\text{th}} \text{ quadrants.})$$

Example 10

By expressing $4 \cos x - 3 \sin x$ in the form $R \cos(x + \alpha)$, where $R > 0$ and $0 < \alpha < \frac{\pi}{2}$,

- (i) obtain the maximum value of $4 \cos x - 3 \sin x + 5$ and the corresponding value of x ,
- (ii) solve the equation $4 \cos x - 3 \sin x = 2.5$ for values of x between 0 and 2π inclusive.

Solution

$$4 \cos x - 3 \sin x = R \cos(x + \alpha)$$

$$R = \sqrt{4^2 + 3^2} = 5$$

$$\tan \alpha = \frac{3}{4}$$

$$\alpha = 0.6435 \text{ (to 4 s.f.)}$$

$$\therefore 4 \cos x - 3 \sin x = 5 \cos(x + 0.644)$$

- (i) Maximum value = $5 + 5$ (Maximum value of $4 \cos x - 3 \sin x$ is 5)
= 10

Maximum value occurs when $\cos(x + 0.6435) = 1$,

$$\text{i.e. } x + 0.6435 = 2\pi$$

$$x = 5.64 \text{ (to 3 s.f.)}$$

- (ii) $4 \cos x - 3 \sin x = 2.5$

$5 \cos(x + 0.6435) = 2.5$ (Use the expression obtained earlier to solve the equation.)
 $\cos(x + 0.6435) = 0.5$

$$\alpha = \frac{\pi}{3}$$

$$x + 0.6435 = 1.047, 5.235 \text{ (to 4 s.f.)} \quad (x + 0.6435 \text{ lies in the 1}^{\text{st}} \text{ and}$$

$$x = 0.404, 4.59 \text{ (to 3 s.f.)} \quad 4^{\text{th}} \text{ quadrants.)}$$

UNIT 10

Proofs in Plane Geometry

(not included for NA)

Useful Properties and Concepts that are learnt in O Level Mathematics

1. Angle Properties

- (a) Alternate angles between parallel lines are equal

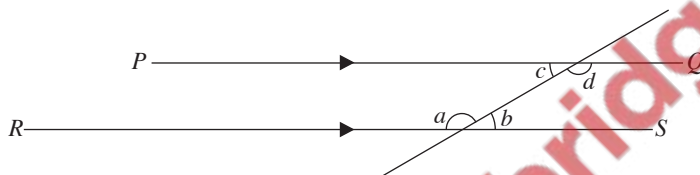

Since $PQ \parallel RS$, $\angle a = \angle d$ and $\angle b = \angle c$

- (b) Corresponding angles between parallel lines are equal

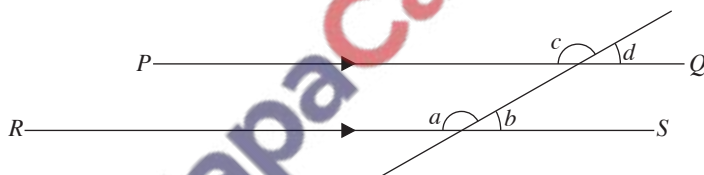

Since $PQ \parallel RS$, $\angle a = \angle c$ and $\angle b = \angle d$

- (c) Interior angles between parallel lines are supplementary

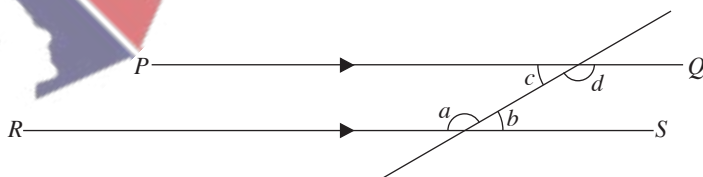

Since $PQ \parallel RS$, $\angle a + \angle c = 180^\circ$ and $\angle b + \angle d = 180^\circ$

2. Properties of Congruent Triangles

- Corresponding sides are equal in length.
- Corresponding angles are equal.

3. Congruence Tests for Triangles

(i) SSS

$$AB = XY, AC = XZ \text{ and } BC = YZ$$

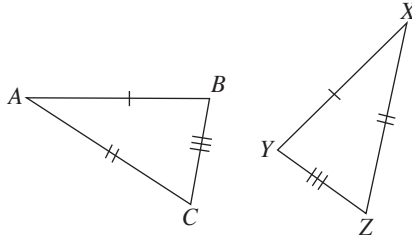

(ii) SAS

$$AB = XY, AC = XZ \text{ and } \angle A = \angle X$$

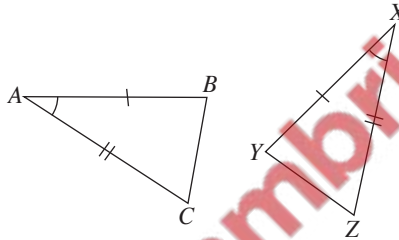

(iii) AAS or ASA

$$AB = XY, \angle A = \angle X \text{ and } \angle B = \angle Y$$

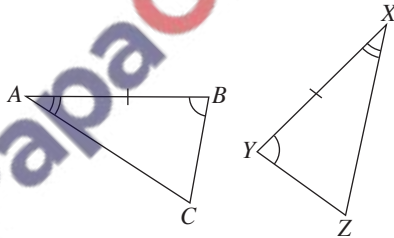

(iv) RHS

Only applicable for right-angled triangles.

$$BC = YZ, AB = XY \text{ and } \angle C = \angle Z = 90^\circ$$

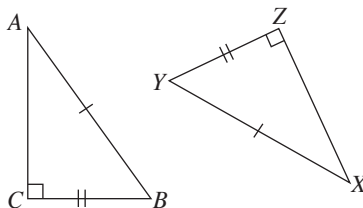

4. Properties of Similar Triangles

- All corresponding angles are equal.
- All corresponding sides are proportional in length.

$$\frac{AE}{AD} = \frac{AB}{AC} = \frac{EB}{DC}$$

$$\frac{\text{Area of } \triangle AEB}{\text{Area of } \triangle ADC} = \left(\frac{AE}{AD}\right)^2$$

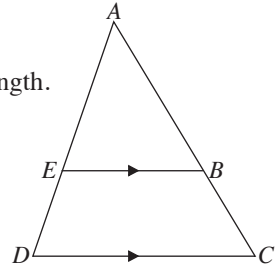

5. Similarity Tests for Triangles

(i) AA

$$\angle A = \angle X \text{ and } \angle B = \angle Y$$

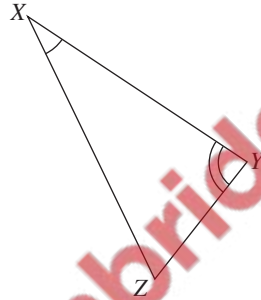
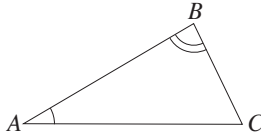

(ii) SSS

$$\frac{AB}{XY} = \frac{BC}{YZ} = \frac{AC}{XZ}$$

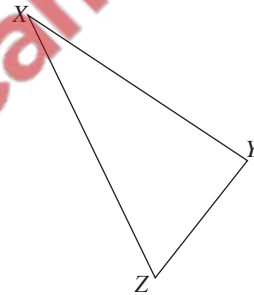
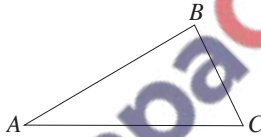

(iii) SAS

$$\frac{AB}{XY} = \frac{BC}{YZ} \text{ and } \angle B = \angle Y$$

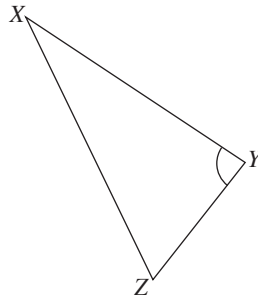
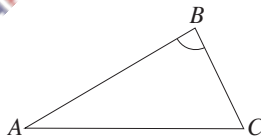

6. Circles

(a) \angle at centre = $2\angle$ at circumference

An angle at the centre is **twice** any angle at the circumference subtended by the **same arc**, i.e. $\angle a = 2\angle b$.

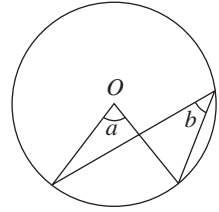

(b) Rt. \angle in a semicircle

Every angle at the circumference subtended by the diameter of a circle is a **right angle**, i.e. $\angle a = 90^\circ$.

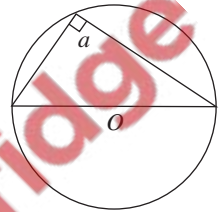

(c) \angle s in the same segment

Angles in the same segment of a circle are **equal**, i.e. $\angle a = \angle b$.

Or

If $AB = BC$, then $\angle ADB = \angle BDC$.

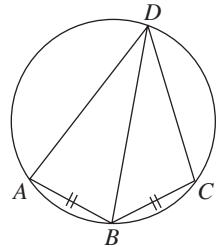
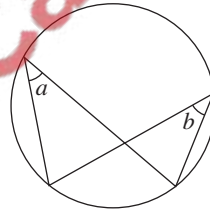

(d) \angle s in opp. segments are supplementary

In a cyclic quadrilateral, the opposite angles are **supplementary**, i.e. $\angle a + \angle c = 180^\circ$ and $\angle b + \angle d = 180^\circ$.

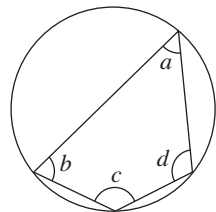

(e) **\perp bisector of a chord passes through the centre of the circle**

A straight line drawn from the centre to bisect a chord is **perpendicular** to the chord, i.e. $OC \perp AB \Leftrightarrow AC = BC$.

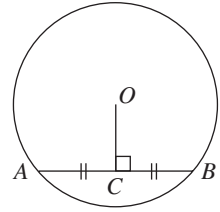

(f) **Equal chords are equidistant from the centre**

Chords which are equidistant from the centre are equal, i.e. $AB = DE \Leftrightarrow OC = OF$.
($\triangle OAB \cong \triangle ODE$)

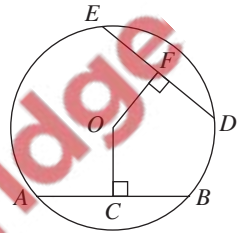

(g) **Tangent \perp radius**

A tangent to a circle is **perpendicular** to the radius drawn to the point of contact, i.e. $OC \perp PQ$.

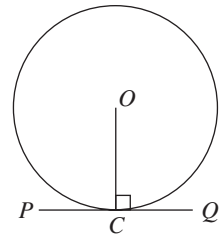

(h) **Tangents from an external point**

(i) Tangents drawn to a circle from an external point are equal, i.e. $PA = PB$.

(ii) The line joining the external point to the centre of the circle bisects the angle between the tangents,

i.e. $\angle APO = \angle BPO$ and $\angle AOP = \angle BOP$.

($\triangle OAP \cong \triangle OBP$)

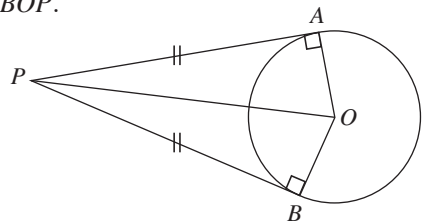

7. Midpoint Theorem for Triangles

In $\triangle ABC$, if D and E are the midpoints of the sides AB and AC respectively, then

$$DE \parallel BC \text{ and } DE = \frac{1}{2} BC.$$

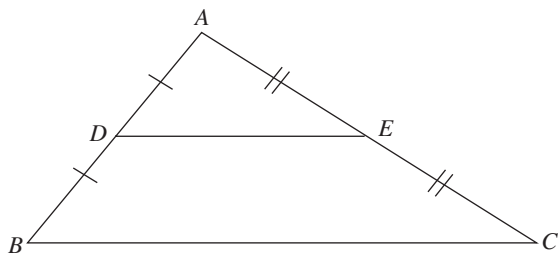

8. Tangent-chord Theorem (Alternate Segment Theorem)

The angle between a tangent and a chord meeting the tangent at the point of contact is equal to the inscribed angle on the opposite side of the chord,

i.e. $\angle BAE = \angle BCA$ and $\angle CAD = \angle CBA$.

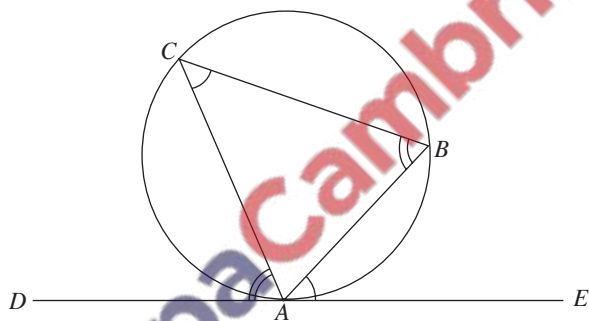

Example 1

The diagram shows a circle, centre O , with diameter AC and $AB = AD$. AC and BD intersect at X .

- (a) Prove that $\triangle ABC$ and $\triangle ADC$ are congruent.
(b) Prove that BD is perpendicular to AC .

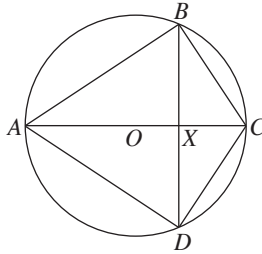

Solution

- (a) $AB = AD$

AC is a common side for the two triangles. (The hypotenuse of both $\angle ABC = \angle ADC = 90^\circ$ (rt. \angle in a semicircle) triangles are the same.)
 $\triangle ABC$ is congruent to $\triangle ADC$ (RHS congruence).

- (b) Since $\triangle ABC$ is congruent to $\triangle ADC$ and they share the same base (AC),
 $BX = DX$.

Since AC passes through the centre of the circle, $AC \perp BD$ (\perp bisector of a chord passes through the centre of the circle).



Example 2

In the figure, BD and FE are tangents to the circle, centre O . BED is a tangent to the circle at B and ACD is a straight line. $\angle CED = 90^\circ$.

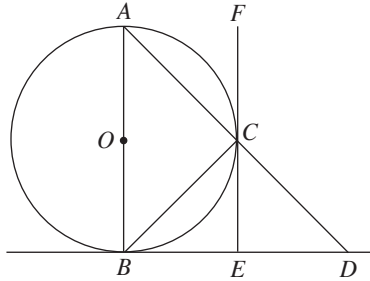

Prove that

- (i) $\angle ABC = \angle ECD$,
- (ii) $\triangle ABD$ is similar to $\triangle BCD$.

Solution

- (i) $\angle ECD = \angle ACF$ (vert. opp. \angle s)
 $\angle ACF = \angle ABC$ (\angle s in alt. segments)
 $\angle ABC = \angle ECD$
- (ii) In $\triangle ABD$ and $\triangle BCD$,
 $\angle BAD = \angle CBD$ (\angle s in alt. segments)
 $\angle ABD = 90^\circ$ (Tangent \perp radius)
 $\angle BCD = \angle BCA = 90^\circ$ (rt. \angle in a semicircle)
i.e. $\angle ABD = \angle BCD$
 $\triangle ABD$ is similar to $\triangle BCD$ (AA Similarity Test).



UNIT 11

Differentiation and its Applications

Formulae

1. $\frac{d}{dx}(x^n) = nx^{n-1}$
2. $\frac{d}{dx}(ax^n) = anx^{n-1}$
3. $\frac{d}{dx}(k) = 0$

Addition/Subtraction Rules

4. If $y = u(x) \pm v(x)$, $\frac{dy}{dx} = \frac{d}{dx}[u(x)] \pm \frac{d}{dx}[v(x)]$

Example 1

Differentiate $2x^3 - 8x^2 + \frac{1}{x^2} - 4$ with respect to x .

Solution

$$\begin{aligned} & \frac{d}{dx} \left(2x^3 - 8x^2 + \frac{1}{x^2} - 4 \right) \\ &= \frac{d}{dx} (2x^3 - 8x^2 + x^{-2} - 4) \quad \left(\text{Change } \frac{1}{x^2} \text{ to } x^{-2}. \right) \\ &= 6x^2 - 16x - 2x^{-3} \\ &= 6x^2 - 16x - \frac{2}{x^3} \end{aligned}$$

Chain Rule

5. If y is a function of u , then $\frac{dy}{dx} = \frac{dy}{du} \times \frac{du}{dx}$
6. $\frac{d}{dx}[(ax + b)^n] = an(ax + b)^{n-1}$
7. In general, $\frac{d}{dx}[f(x)]^n = n[f(x)]^{n-1} \times f'(x)$

Example 2

Differentiate $\sqrt{5 - 4x^2}$ with respect to x .

Solution

$$\begin{aligned} & \frac{d}{dx}(\sqrt{5 - 4x^2}) \\ &= \frac{d}{dx}(5 - 4x^2)^{\frac{1}{2}} \\ &= \frac{1}{2}(5 - 4x^2)^{-\frac{1}{2}}(-8x) \quad (\text{Chain Rule}) \\ &= -\frac{4x}{\sqrt{5 - 4x^2}} \end{aligned}$$

Product Rule

8. If $y = uv$, where u and v are functions of x , then $\frac{dy}{dx} = u \frac{dv}{dx} + v \frac{du}{dx}$

Example 3

Differentiate $2x(3x^3 - 2)^3$ with respect to x .

Solution

$$\begin{aligned} & \frac{d}{dx} [2x(3x^3 - 2)^3] \\ &= 2x(3)(3x^3 - 2)^2(9x^2) + 2(3x^3 - 2)^3 \quad (\text{Product Rule and Chain Rule}) \\ &= 2(3x^3 - 2)^2(27x^3 + 3x^3 - 2) \quad (\text{Take out common factors.}) \\ &= 2(3x^3 - 2)^2(30x^3 - 2) \\ &= 4(3x^3 - 2)^2(15x^3 - 1) \end{aligned}$$

Quotient Rule

9. If $y = \frac{u}{v}$, where u and v are functions of x , then $\frac{dy}{dx} = \frac{v \frac{du}{dx} - u \frac{dv}{dx}}{v^2}$

Example 4

Differentiate $\frac{3x^2 + 4}{\sqrt{2x + 5}}$ with respect to x .

Solution

$$\begin{aligned} & \frac{d}{dx} \left[\frac{3x^2 + 4}{\sqrt{2x + 5}} \right] \\ &= \frac{6x\sqrt{2x + 5} - (3x^2 + 4)\left(\frac{1}{2}\right)(2x + 5)^{-\frac{1}{2}}(2)}{2x + 5} \quad (\text{Quotient Rule}) \\ &= \frac{6x(2x + 5) - (3x^2 + 4)}{(2x + 5)^{\frac{3}{2}}} \\ &= \frac{9x^2 + 30x - 4}{\sqrt{(2x + 5)^3}} \end{aligned}$$

Equations of Tangent and Normal to a Curve

10. Equation of a straight line: $y - y_1 = m(x - x_1)$

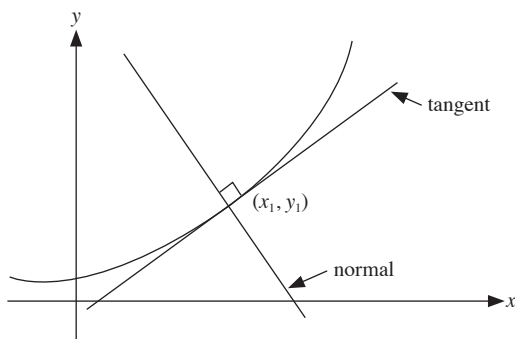

11. To find the equation of a tangent, we need:

$$\text{Gradient of tangent, } m = \frac{dy}{dx}$$

Coordinates of a point that lies on the tangent, (x_1, y_1)

12. To find the equation of a normal, we need:

$$\text{Gradient of tangent} = \frac{dy}{dx}$$

$$\text{Gradient of normal} = -1 \div \frac{dy}{dx}$$

Coordinates of a point that lies on the normal, (x_1, y_1)



Example 5

A curve has the equation $y = x^2 + 3x$.

- (i) Find the equation of the tangent to the curve at $(1, 4)$.
- (ii) Find the equation of the normal to the curve at $(1, 4)$.

Solution

- (i) **Step 1:** Find $\frac{dy}{dx}$.

$$\frac{dy}{dx} = 2x + 3$$

Step 2: Substitute $x = 1$ into $\frac{dy}{dx}$ to find the gradient of the tangent.

$$\begin{aligned}\frac{dy}{dx} &= 2(1) + 3 \\ &= 5\end{aligned}$$

Step 3: Find the equation of the tangent.

$$\begin{aligned}y - 4 &= 5(x - 1) \\ y - 4 &= 5x - 5 \\ y &= 5x - 1\end{aligned}$$

- (ii) **Step 1:** Find the gradient of the normal.

$$\begin{aligned}\text{Gradient of normal} &= -\frac{1}{\text{Gradient of tangent}} \\ &= -\frac{1}{5}\end{aligned}$$

Step 2: Find the equation of the normal.

$$\begin{aligned}y - 4 &= -\frac{1}{5}(x - 1) \\ 5y - 20 &= -x + 1 \\ 5y &= -x + 21\end{aligned}$$



Example 6

The equation of a curve is $y = \frac{5}{1-3x}$. Find

- (i) $\frac{dy}{dx}$,
- (ii) the equation of the tangent to the curve at $x = 2$,
- (iii) the equation of the normal to the curve at $x = 2$.

Solution

(i) $y = \frac{5}{1-3x}$

$$\begin{aligned}\frac{dy}{dx} &= \frac{(1-3x)(0) - 5(-3)}{(1-3x)^2} \\ &= \frac{15}{(1-3x)^2}\end{aligned}$$

- (ii) When $x = 2$,

$$y = -1$$

$$\frac{dy}{dx} = \frac{3}{5}$$

$$\therefore \text{Equation of tangent: } y + 1 = \frac{3}{5}(x - 2)$$

$$y = \frac{3}{5}x - \frac{11}{5}$$

- (iii) Gradient of normal = $-\frac{5}{3}$ ($m_1 m_2 = -1$)

$$\therefore \text{Equation of normal: } y + 1 = -\frac{5}{3}(x - 2)$$

$$y = -\frac{5}{3}x + \frac{7}{3}$$

Connected Rates of Change

13. If $\frac{dx}{dt}$ is the rate of change of x with respect to time t and $y = f(x)$, then the rate of change of y with respect to t is given by $\frac{dy}{dt} = \frac{dy}{dx} \times \frac{dx}{dt}$.
14. A positive rate of change is an increase in the magnitude of the quantity involved as the time increases.
15. A negative rate of change is a decrease in the magnitude of the quantity involved as the time increases.

Example 7

Two variables, x and y , are related by the equation $y = \frac{x}{3x+7}$. Find the rate of change of x at the instant when $x = 1$, given that y is changing at a rate of 3.5 units/s at this instant.

Solution

$$y = \frac{x}{3x+7}$$

$$\frac{dy}{dx} = \frac{(3x+7)(1) - x(3)}{(3x+7)^2}$$

$$= \frac{3x+7-3x}{(3x+7)^2}$$

$$= \frac{7}{(3x+7)^2}$$

Using $\frac{dy}{dt} = \frac{dy}{dx} \times \frac{dx}{dt}$,

$$3.5 = \frac{7}{(3+7)^2} \times \frac{dx}{dt}$$

$$\frac{dx}{dt} = 50 \text{ units/s}$$

Example 8

A cube has sides of x cm. Its volume, V cm³, is expanding at a rate of 30 cm³/s. Find the rate of change of x of the cube when the volume is 64 cm³.

Solution

$$V = x^3$$

$$\frac{dV}{dx} = 3x^2$$

When $V = 64$, $x = 4$.

When $x = 4$,

$$\begin{aligned}\frac{dV}{dx} &= 3(4)^2 \\ &= 48\end{aligned}$$

Given that $\frac{dV}{dt} = 30$,

$$\frac{dV}{dt} = \frac{dV}{dx} \times \frac{dx}{dt}$$

$$30 = 48 \times \frac{dx}{dt}$$

$$\frac{dx}{dt} = 0.625 \text{ cm/s}$$

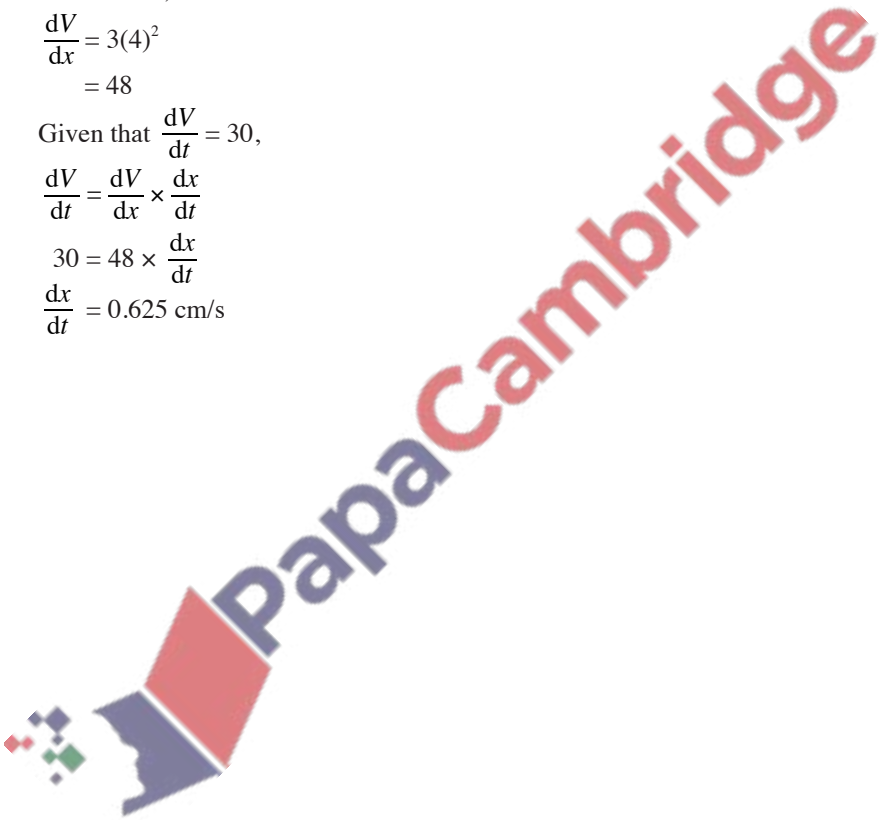

UNIT 12

Further Applications of Differentiation

Increasing/Decreasing Functions

1.

Function in x	y	$f(x)$
First derivative	$\frac{dy}{dx}$	$f'(x)$
Second derivative	$\frac{d^2y}{dx^2}$	$f''(x)$
Third derivative	$\frac{d^3y}{dx^3}$	$f'''(x)$

2. If y is an increasing function (y increases as x increases), the gradient is positive,

i.e. $\frac{dy}{dx} > 0$.

e.g.

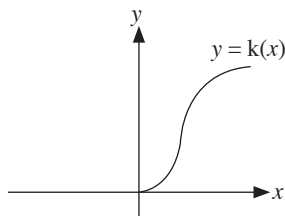
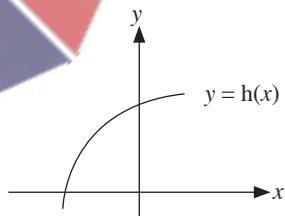
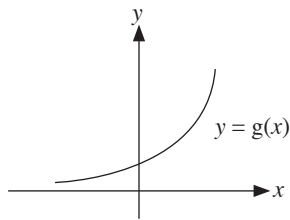
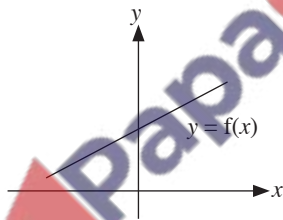

Example 1

Find the set of values of x for which $f(x) = 2x^3 - 10x^2 + 14x + 5$ is an increasing function.

Solution

$$f(x) = 2x^3 - 10x^2 + 14x + 5$$

$$f'(x) = 6x^2 - 20x + 14$$

When $f'(x) > 0$,

$$6x^2 - 20x + 14 > 0$$

$$3x^2 - 10x + 7 > 0$$

$$(3x - 7)(x - 1) > 0$$

$$x < 1 \quad \text{or} \quad x > \frac{7}{3}$$

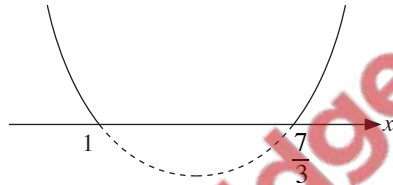

3. If y is a decreasing function (y decreases as x increases), the gradient is negative, i.e. $\frac{dy}{dx} < 0$.

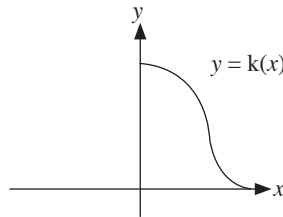
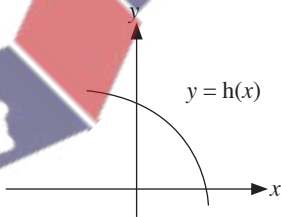
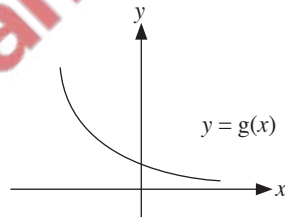
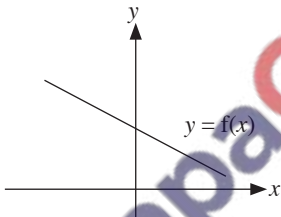

Example 2

Find the set of values of x for which $y = \frac{1}{3}x^3 - \frac{5}{2}x^2 + 6x$ is a decreasing function.

Solution

$$y = \frac{1}{3}x^3 - \frac{5}{2}x^2 + 6x$$

$$\frac{dy}{dx} = x^2 - 5x + 6$$

For y to be a decreasing function, $\frac{dy}{dx} < 0$.

$$x^2 - 5x + 6 < 0$$

$$(x-3)(x-2) < 0$$

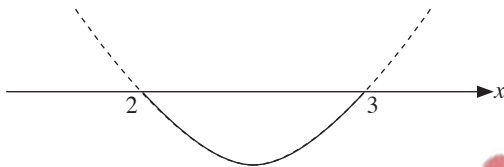

$$\therefore 2 < x < 3$$

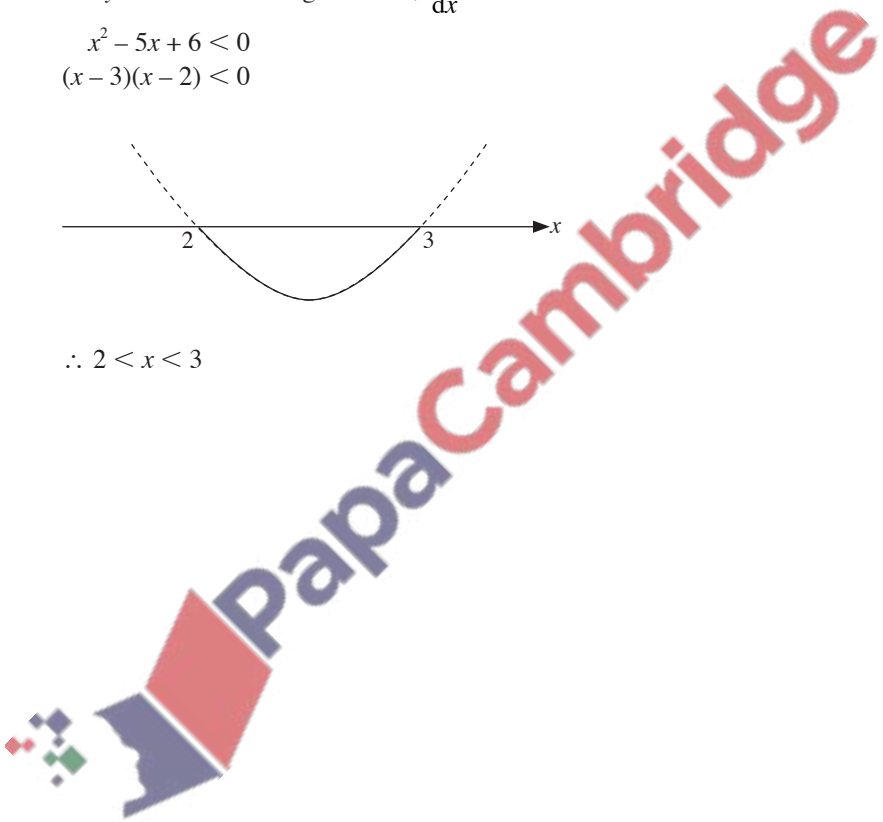

Stationary Points

4. If a point (x_0, y_0) is a stationary point of the curve $y = f(x)$, then $\frac{dy}{dx} = 0$ when $x = x_0$, i.e. the gradient of the tangent at $x = x_0$ is zero.
5. A stationary point can be a maximum point, a minimum point or a point of inflexion.

Determining the Nature of Stationary Points

6. **First Derivative Test:** Use $\frac{dy}{dx}$.

Maximum point

	x^-	x_0	x^+
$\frac{dy}{dx}$	> 0	0	< 0
slope	/	-	\
stationary point			

Minimum point

	x^-	x_0	x^+
$\frac{dy}{dx}$	< 0	0	> 0
slope	\	-	/
stationary point			

Point of inflexion

	x^-	x_0	x^+
$\frac{dy}{dx}$	> 0	0	> 0
slope	/	-	/
stationary point			

Point of inflexion

	x^-	x_0	x^+
$\frac{dy}{dx}$	< 0	0	< 0
slope	\	-	\
stationary point			



7. **Second Derivative Test:** Use $\frac{d^2y}{dx^2}$.
- If $\frac{d^2y}{dx^2} < 0$, the stationary point is a maximum point.
 - If $\frac{d^2y}{dx^2} > 0$, the stationary point is a minimum point.
 - If $\frac{d^2y}{dx^2} = 0$, the stationary point can be a maximum point, a minimum point or a point of inflexion. Use the First Derivative Test to determine the nature.

Problems on Maxima and Minima

8. **Step 1:** Find a relationship between the quantity to be maximised or minimised and the variable(s) involved.
- Step 2:** If there is more than one variable involved, use substitution to reduce it to one independent variable only.
- Step 3:** Find the first derivative of the expression obtained above.
- Step 4:** Equate the first derivative to zero to obtain the value(s) of the variable.
- Step 5:** Check the nature of the stationary point.
- Step 6:** Find the required maximum or minimum value of the quantity.



Example 3

A curve has the equation $y = 3(x + 1)^2$. Find the coordinates of the stationary point and deduce the nature of the stationary point.

Solution

$$\frac{dy}{dx} = 6(x + 1)$$





Let $\frac{dy}{dx} = 0$,

$$6(x + 1) = 0$$

$$x = -1$$

When $x = -1$, $y = 0$.

To find the nature of the stationary point, we perform the First Derivative Test.

x	-1.1	-1	-0.9
$\frac{dy}{dx}$	< 0	0	> 0
slope			
stationary point			

$(-1, 0)$ is a minimum point.



Example 4

It is given that $y = \frac{16}{x^4}$ and that $z = x^2 + 2y$. Given that x is positive, find the value of x and of y that makes z a stationary value and show that in this case, z has a minimum value.

Solution

$$y = \frac{16}{x^4} \quad \text{--- (1)}$$

$$z = x^2 + 2y \quad \text{--- (2)}$$

Substitute (1) into (2): (Express z in terms of one variable.)

$$\begin{aligned} z &= x^2 + \frac{32}{x^4} \\ &= x^2 + 32x^{-4} \end{aligned}$$

$$\begin{aligned} \frac{dz}{dx} &= 2x - 128x^{-5} \\ &= 2x - \frac{128}{x^5} \end{aligned}$$

$$\text{When } \frac{dz}{dx} = 0,$$

$$2x - \frac{128}{x^5} = 0$$

$$2x = \frac{128}{x^5}$$

$$x^6 = 64$$

$$x = \pm 2$$

Given that x is positive,

$$x = 2$$

$y = 1$ (Substitute $x = 2$ into (1) to obtain the value of y .)

$$\begin{aligned} \frac{d^2z}{dx^2} &= 2 + 640x^{-6} \quad \text{(Use the Second Derivative Test to show that } z \text{ has a} \\ &= 2 + \frac{640}{x^6} \quad \text{minimum value.)} \end{aligned}$$

When $x = 2$,

$$\frac{d^2z}{dx^2} = 12 > 0$$

$\therefore z$ has a minimum value.

Example 5

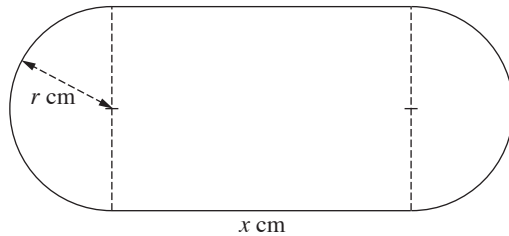

The diagram shows a rectangle of length x cm and 2 semicircles each of radius r cm. The perimeter of the figure is 400 cm and the area of the rectangle is A cm².

- (a) Show that $A = 400r - 2\pi r^2$.
- (b) Find an expression for $\frac{dA}{dr}$.
- (c) Calculate
- the value of r for which A is a maximum,
 - the maximum value of A .

Solution

- (a) Given that the perimeter is 400 cm,
- $$2x + 2\pi r = 400 \quad (\text{As } A \text{ is expressed in terms of } r \text{ only, we make use of}$$
- $$x = 200 - \pi r \quad \text{the perimeter to obtain an equation involving } x \text{ and } r,$$
- $$A = x(2r) \quad \text{before substituting it into } A.)$$
- $$= 2r(200 - \pi r)$$
- $$= 400r - 2\pi r^2 \quad (\text{proven})$$
- (b) $\frac{dA}{dr} = 400 - 4\pi r$

(c) (i) When $\frac{dA}{dr} = 0$,

$$400 - 4\pi r = 0$$

$$r = \frac{100}{\pi}$$

$$\frac{d^2A}{dr^2} = -4\pi < 0 \quad (\text{Use the Second Derivative Test to check that } A \text{ is a maximum.})$$

$\therefore A$ is a maximum.

(ii) When $r = \frac{100}{\pi}$,

$$A = 400\left(\frac{100}{\pi}\right) - 2\pi\left(\frac{100}{\pi}\right)^2$$

$$= \frac{40\,000}{\pi} - \frac{20\,000}{\pi}$$

$$= \frac{20\,000}{\pi}$$

$$= 6370 \text{ (to 3 s.f.)}$$

\therefore The maximum value of A is 6370 (to 3 s.f.).



Example 6

A cylinder, which is made using a thin sheet of metal, has a volume of 500 cm^3 , radius of $x \text{ cm}$ and height of $h \text{ cm}$.

- (a) Express h in terms of x and hence, express the total surface area, $A \text{ cm}^2$, in terms of x .
- (b) Find the value of x for which A will be a minimum.

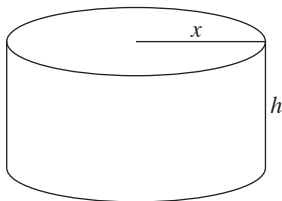

Solution

(a) $V = \pi x^2 h$

$$\pi x^2 h = 500$$

$$h = \frac{500}{\pi x^2}$$

$$\begin{aligned} A &= 2\pi x^2 + 2\pi x \left(\frac{500}{\pi x^2} \right) \\ &= 2\pi x^2 + \frac{1000}{x} \end{aligned}$$

(b) $A = 2\pi x^2 + 1000x^{-1}$

$$\frac{dA}{dx} = 4\pi x - 1000x^{-2}$$

$$= 4\pi x - \frac{1000}{x^2}$$

To find the minimum value of A , $\frac{dA}{dx} = 0$.

$$4\pi x - \frac{1000}{x^2} = 0$$

$$x^3 = \frac{250}{\pi}$$

$$x = \sqrt[3]{\frac{250}{\pi}}$$

$$= 4.30 \text{ (to 3 s.f.)}$$

UNIT 13

Differentiation of Trigonometric, Logarithmic & Exponential Functions and their Applications

(not included for NA)

Differentiation of Trigonometric Functions

1. Ensure that your calculator is in the radian mode.

$$2. \quad \frac{d}{dx} (\sin x) = \cos x$$

$$\frac{d}{dx} (\cos x) = -\sin x$$

$$\frac{d}{dx} (\tan x) = \sec^2 x$$

$$\frac{d}{dx} (\sec x) = \sec x \tan x$$

$$\frac{d}{dx} (\cot x) = -\operatorname{cosec}^2 x$$

$$\frac{d}{dx} (\operatorname{cosec} x) = \operatorname{cosec} x \cot x$$

$$3. \quad \frac{d}{dx} [\sin (Ax + B)] = A \cos (Ax + B)$$

$$\frac{d}{dx} [\cos (Ax + B)] = -A \sin (Ax + B)$$

$$\frac{d}{dx} [\tan (Ax + B)] = A \sec^2 (Ax + B)$$

Example 1

Differentiate each of the following with respect to x .

(a) $3 \sin (2x + 1)$

(b) $(2x + 1) \cos 3x$

(c) $x^3 \tan (3x + 2)$

Solution

$$(a) \quad \frac{d}{dx} [3 \sin (2x + 1)] = 3[2 \cos (2x + 1)] \\ = 6 \cos (2x + 1)$$

$$(b) \quad \frac{d}{dx} (2x + 1) \cos 3x = (2x + 1)(3)(-\sin 3x) + \cos 3x (2) \quad (\text{Product Rule}) \\ = -3(2x + 1) \sin 3x + 2 \cos 3x$$

$$(c) \quad \frac{d}{dx} [x^3 \tan (3x + 2)] = x^3(3) \sec^2 (3x + 2) + \tan (3x + 2)(3x^2) \quad (\text{Product Rule}) \\ = 3x^2 [x \sec^2 (3x + 2) + \tan (3x + 2)]$$

Example 2

Find the gradient of the curve $y = x \sin x$ at the point where $x = 1$.

Solution

$$y = x \sin x$$

$$\frac{dy}{dx} = x \cos x + \sin x \quad (\text{Gradient of curve refers to } \frac{dy}{dx}.)$$

When $x = 1$,

$$\frac{dy}{dx} = \cos 1 + \sin 1 \quad (\text{Radian mode})$$

$$= 1.38 \text{ (to 3 s.f.)}$$

\therefore Gradient of curve at $x = 1$ is 1.38

4. $\frac{d}{dx}[\sin^n x] = n \sin^{n-1} x \cos x$

$$\frac{d}{dx}[\cos^n x] = -n \cos^{n-1} x \sin x$$

$$\frac{d}{dx}[\tan^n x] = n \tan^{n-1} x \sec^2 x$$

5. $\frac{d}{dx}[\sin^n(Ax + B)] = An \sin^{n-1}(Ax + B) \cos(Ax + B)$

$$\frac{d}{dx}[\cos^n(Ax + B)] = -An \cos^{n-1}(Ax + B) \sin(Ax + B)$$

$$\frac{d}{dx}[\tan^n(Ax + B)] = An \tan^{n-1}(Ax + B) \sec^2(Ax + B)$$

In general,

6. $\frac{d}{dx}[\sin^n f(x)] = n \sin^{n-1} f(x) \times \frac{d}{dx}[\sin f(x)]$

◆ $\frac{d}{dx}[\cos^n f(x)] = n \cos^{n-1} f(x) \times \frac{d}{dx}[\cos f(x)]$

$$\frac{d}{dx}[\tan^n f(x)] = n \tan^{n-1} f(x) \times \frac{d}{dx}[\tan f(x)]$$

Example 3

Differentiate each of the following with respect to x .

- (a) $\cos^2(1 - 3x)$
- (b) $3 \tan^3(2x - \pi)$
- (c) $\sin^2(3x + 2) \cos x^2$

Solution

$$\begin{aligned} \text{(a)} \quad \frac{d}{dx} [\cos^2(1 - 3x)] &= 2 \cos(1 - 3x) [-(3) \sin(1 - 3x)] \\ &= 6 \cos(1 - 3x) \sin(1 - 3x) \end{aligned}$$

$$\begin{aligned} \text{(b)} \quad \frac{d}{dx} [3 \tan^3(2x - \pi)] &= 3[(3) \tan^2(2x - \pi)][(2) \sec^2(2x - \pi)] \quad (\text{Chain Rule}) \\ &= 18 \tan^2(2x - \pi) \sec^2(2x - \pi) \end{aligned}$$

$$\begin{aligned} \text{(c)} \quad \frac{d}{dx} [\sin^2(3x + 2) \cos x^2] \\ &= (2) \sin(3x + 2) (3) \cos(3x + 2) (\cos x^2) + \sin^2(3x + 2) (2x) (-\sin x^2) \\ &= 6 \sin(3x + 2) \cos(3x + 2) \cos x^2 - 2x \sin^2(3x + 2) \sin x^2 \quad (\text{Product Rule and Chain Rule}) \end{aligned}$$

Differentiation of Logarithmic Functions

$$7. \quad \frac{d}{dx} (\ln x) = \frac{1}{x}$$

$$8. \quad \frac{d}{dx} [\ln(ax + b)] = \frac{a}{ax + b}$$

$$9. \quad \text{In general, } \frac{d}{dx} [\ln f(x)] = \frac{f'(x)}{f(x)}, \text{ where } f'(x) = \frac{d}{dx} [f(x)].$$

10. As far as possible, make use of the laws of logarithms to simplify logarithmic expressions before finding the derivatives.

Example 4

Differentiate each of the following with respect to x .

(a) $\ln(3x + 1)$

(b) $\ln(2x^2 + 5)^3$

(c) $\ln\left(\frac{2x}{3x^2 + 4}\right)$

(d) $\ln\left(\frac{8 + 4x}{3x - 5}\right)$

(e) $\ln[x(5x^3 - 2)]$

(f) $x^3 \ln(4x - 1)$

Solution

(a) $\frac{d}{dx}[\ln(3x + 1)] = \frac{3}{3x + 1}$

(b) $\frac{d}{dx}[\ln(2x^2 + 5)^3] = \frac{d}{dx}[3 \ln(2x^2 + 5)]$
 $= 3\left(\frac{4x}{2x^2 + 5}\right)$ (Power Law of Logarithms)
 $= \frac{12x}{2x^2 + 5}$

(c) $\frac{d}{dx}\left[\ln\left(\frac{2x}{3x^2 + 4}\right)\right] = \frac{d}{dx}[\ln 2x - \ln(3x^2 + 4)]$
 $= \frac{2}{2x} - \frac{6x}{3x^2 + 4}$
 $= \frac{1}{x} - \frac{6x}{3x^2 + 4}$

(d) $\frac{d}{dx}\left[\ln\left(\frac{8 + 4x}{3x - 5}\right)\right] = \frac{d}{dx}[\ln(8 + 4x) - \ln(3x - 5)]$
 $= \frac{4}{8 + 4x} - \frac{3}{3x - 5}$
 $= \frac{1}{2 + x} - \frac{3}{3x - 5}$

$$\begin{aligned} \text{(e)} \quad \frac{d}{dx} \ln[x(5x^3 - 2)] &= \frac{d}{dx} [\ln x + \ln(5x^3 - 2)] \\ &= \frac{1}{x} + \frac{15x^2}{5x^3 - 2} \end{aligned}$$

$$\begin{aligned} \text{(f)} \quad \frac{d}{dx} [x^3 \ln(4x - 1)] &= x^3 \left(\frac{4}{4x - 1} \right) + 3x^2 \ln(4x - 1) \\ &= \frac{4x^3}{4x - 1} + 3x^2 \ln(4x - 1) \end{aligned}$$

Example 5

Two variables, x and y , are related by the equation $y = \frac{\ln x}{3x + 7}$. Find the rate of change of x at the instant when $x = 1$, given that y is changing at a rate of 0.18 units/s at this instant.

Solution

$$y = \frac{\ln x}{3x + 7}$$

$$\begin{aligned} \frac{dy}{dx} &= \frac{(3x + 7) \left(\frac{1}{x} \right) - 3 \ln x}{(3x + 7)^2} \\ &= \frac{3x + 7 - 3x \ln x}{x(3x + 7)^2} \end{aligned}$$

Using $\frac{dy}{dt} = \frac{dy}{dx} \times \frac{dx}{dt}$,

$$0.18 = \frac{3(1) + 7 - 3(1) \ln 1}{1(3 + 7)^2} \times \frac{dx}{dt}$$

$$\frac{dx}{dt} = 1.8 \text{ units/s}$$

Example 6

x and y are related by the equation $y = \frac{\ln 2x}{3x^2}$. Find the rate of change of y at the instant when $y = 0$, given that x is changing at a rate of 2 units/s at this instant.

Solution

$$\begin{aligned}y &= \frac{\ln 2x}{3x^2} \\&= \frac{1}{3}x^{-2} \ln 2x \\ \frac{dy}{dx} &= \frac{1}{3}(-2)x^{-3} \ln 2x + \frac{1}{3}x^{-2} \left(\frac{2}{2x}\right) \quad (\text{Product Rule}) \\&= -\frac{2 \ln 2x}{3x^3} + \frac{1}{3x^3} \\&= \frac{1 - 2 \ln 2x}{3x^3}\end{aligned}$$

When $y = 0$,

$$\ln 2x = 0$$

$$2x = e^0$$

$$x = \frac{1}{2}$$

Using $\frac{dy}{dt} = \frac{dy}{dx} \times \frac{dx}{dt}$,

$$\begin{aligned}\frac{dy}{dt} &= \left[\frac{1 - 2 \ln 2 \left(\frac{1}{2}\right)}{3 \left(\frac{1}{2}\right)^3} \right] \times 2 \\&= 5\frac{1}{3} \text{ units/s}\end{aligned}$$

Differentiation of Exponential Functions

11. $\frac{d}{dx}(e^x) = e^x$

12. $\frac{d}{dx}(e^{ax+b}) = ae^{ax+b}$

13. In general, $\frac{d}{dx}(e^{f(x)}) = f'(x)e^{f(x)}$, where $f'(x) = \frac{d}{dx}[f(x)]$.

Example 7

Differentiate each of the following with respect to x .

(a) e^{2-3x}

(b) x^2e^{4x}

(c) $\frac{e^{3x}}{x^2+1}$

(d) $\frac{e^{\sin x} + 1}{e^{\cos x}}$

Solution

(a) $\frac{d}{dx}(e^{2-3x}) = -3e^{2-3x}$

(b) $\frac{d}{dx}(x^2e^{4x}) = x^2(4e^{4x}) + 2xe^{4x}$ (Product Rule)
 $= 2xe^{4x}(2x+1)$

(c) $\frac{d}{dx}\left[\frac{e^{3x}}{x^2+1}\right] = \frac{(x^2+1)(3e^{3x}) - e^{3x}(2x)}{(x^2+1)^2}$ (Quotient Rule)
 $= \frac{3(x^2+1)e^{3x} - 2xe^{3x}}{(x^2+1)^2}$
 $= \frac{e^{3x}[3(x^2+1) - 2x]}{(x^2+1)^2}$

(d) $\frac{d}{dx}\left(\frac{e^{\sin x} + 1}{e^{\cos x}}\right) = \frac{e^{\cos x}(\cos x e^{\sin x}) - (e^{\sin x} + 1)e^{\cos x}(-\sin x)}{(e^{\cos x})^2}$ (Quotient Rule)
 $= \frac{e^{\cos x} e^{\sin x} \cos x + (e^{\sin x} + 1)e^{\cos x} \sin x}{e^{2\cos x}}$
 $= \frac{e^{\cos x} [e^{\sin x} \cos x + (e^{\sin x} + 1)\sin x]}{e^{2\cos x}}$
 $= \frac{e^{\sin x} \cos x + (e^{\sin x} + 1)\sin x}{e^{\cos x}}$

Example 8

The equation of a curve is $y = e^x \cos x$, where $0 < x < \pi$.
Find the x -coordinate of the stationary point of the curve.

Solution

$$y = e^x \cos x$$

$$\frac{dy}{dx} = e^x (-\sin x) + \cos x (e^x)$$

$$= e^x (\cos x - \sin x)$$

When $\frac{dy}{dx} = 0$,

$$e^x (\cos x - \sin x) = 0$$

$$e^x = 0 \text{ (no solution)}$$

or

$$\cos x - \sin x = 0$$

$$\cos x = \sin x$$

$$\tan x = 1$$

$$x = \frac{\pi}{4}$$

Example 9

Given that the equation of a curve is $y = e^{\frac{1}{2}x} + \frac{4}{e^{\frac{1}{2}x}}$,

- (i) find the coordinates of the stationary point on the curve,
- (ii) determine the nature of the stationary point.

Solution

(i) $y = e^{\frac{1}{2}x} + \frac{4}{e^{\frac{1}{2}x}}$

$$= e^{\frac{1}{2}x} + 4e^{-\frac{1}{2}x}$$

$$\frac{dy}{dx} = \frac{1}{2}e^{\frac{1}{2}x} + 4\left(-\frac{1}{2}\right)e^{-\frac{1}{2}x}$$

$$= \frac{1}{2}e^{\frac{1}{2}x} - 2e^{-\frac{1}{2}x}$$

When $\frac{dy}{dx} = 0$,

$$\frac{1}{2}e^{\frac{1}{2}x} - 2e^{-\frac{1}{2}x} = 0$$

$$\frac{1}{2}e^{\frac{1}{2}x} = 2e^{-\frac{1}{2}x}$$

$$\frac{e^{\frac{1}{2}x}}{e^{-\frac{1}{2}x}} = 4$$

$$e^x = 4$$

$$x = \ln 4$$

$$y = e^{\frac{1}{2}\ln 4} + \frac{4}{e^{\frac{1}{2}\ln 4}}$$

$$= 2 + \frac{4}{2}$$

$$= 4$$

\therefore Coordinates of stationary point are $(\ln 4, 4)$

$$\begin{aligned} \text{(ii)} \quad \frac{d^2y}{dx^2} &= \left(\frac{1}{2}\right)\left(\frac{1}{2}\right)e^{\frac{1}{2}x} - (2)\left(-\frac{1}{2}\right)e^{-\frac{1}{2}x} \\ &= \frac{1}{4}e^{\frac{1}{2}x} + e^{-\frac{1}{2}x} \end{aligned}$$

When $x = \ln 4$,

$$\frac{d^2y}{dx^2} = 1 > 0$$

\therefore The stationary point is a minimum.



Integration

1. If $y = f(x)$, then $\int y \, dx = \int f(x) \, dx$.
2. If $\frac{dy}{dx} = g(x)$, then $\int g(x) \, dx = y + c$, where c is an arbitrary constant.

Formulae and Rules

3. $\int k \, dx = kx + c$, where k is a constant
4. $\int ax^n \, dx = \frac{ax^{n+1}}{n+1} + c$, where $n \neq -1$
5. $\int (ax + b)^n \, dx = \frac{(ax + b)^{n+1}}{a(n+1)} + c$, where $n \neq -1$
6. $\int [f(x) \pm g(x)] \, dx = \int f(x) \, dx \pm \int g(x) \, dx$

Example 1

Find

(a) $\int 5 \, dx$,

(b) $\int 3x^5 \, dx$,

(c) $\int (2x^3 - 3x + 6) \, dx$,

(d) $\int x \left(3x^2 + \frac{7}{x} \right) dx$,

(e) $\int 3(2x - 5)^6 \, dx$.

Solution

$$(a) \int 5 \, dx = 5x + c$$

$$(b) \int 3x^5 \, dx = \frac{3x^{5+1}}{5+1} + c \\ = \frac{1}{2} x^6 + c$$

$$(c) \int (2x^3 - 3x + 6) \, dx = \frac{2x^{3+1}}{3+1} - \frac{3x^{1+1}}{1+1} + 6x + c \\ = \frac{1}{2} x^4 - \frac{3}{2} x^2 + 6x + c$$

$$(d) \int x \left(3x^2 + \frac{7}{x} \right) dx = \int (3x^3 + 7) \, dx \quad \text{(Multiply } x \text{ into the terms in the bracket} \\ \text{before doing the integration.)} \\ = \frac{3x^{3+1}}{3+1} + 7x + c \\ = \frac{3}{4} x^4 + 7x + c$$

$$(e) \int 3(2x-5)^6 \, dx = \frac{3(2x-5)^{6+1}}{(6+1)(2)} + c \quad \text{(It is not necessary to find the expansion} \\ \text{of } (2x-5)^6 \text{.)} \\ = \frac{3}{14} (2x-5)^7 + c$$

Example 2

Find the equation of the curve which passes through the point (2, 10) and

for which $\frac{dy}{dx} = 3x^2 - \frac{4}{x^2}$.

Solution

$$\frac{dy}{dx} = 3x^2 - \frac{4}{x^2} \\ = 3x^2 - 4x^{-2}$$

$$y = \int (3x^2 - 4x^{-2}) \, dx \\ = x^3 + 4x^{-1} + c \\ = x^3 + \frac{4}{x} + c$$

When $x = 2$, $y = 10$,

$$10 = 2^3 + \frac{4}{2} + c$$

$$c = 0$$

\therefore Equation of the curve is $y = x^3 + \frac{4}{x}$

Integration of Trigonometric Functions

7. $\int \sin x \, dx = -\cos x + c$

8. $\int \cos x \, dx = \sin x + c$

9. $\int \sec^2 x \, dx = \tan x + c$

10. $\int \sin (Ax + B) \, dx = -\frac{1}{A} \cos (Ax + B) + c$

11. $\int \cos (Ax + B) \, dx = \frac{1}{A} \sin (Ax + B) + c$

12. $\int \sec^2 (Ax + B) \, dx = \frac{1}{A} \tan (Ax + B) + c$

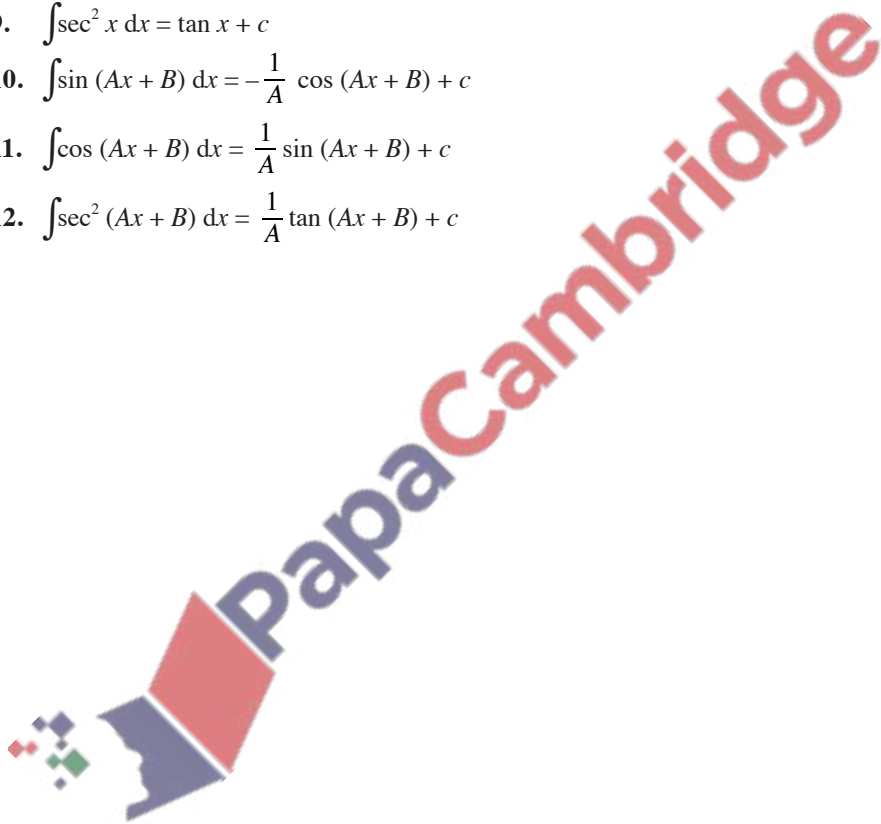

Example 3

Find

(a) $\int \cos(5x + 3) dx$, (b) $\int 3 \sin(3x - 1) dx$,

(c) $\int 2 \sec^2(8 - 3x) dx$.

Solution

(a) $\int \cos(5x + 3) dx = \frac{1}{5} \sin(5x + 3) + c$

(b) $\int 3 \sin(3x - 1) dx = 3 \left[\frac{-\cos(3x - 1)}{3} \right] + c$
 $= -\cos(3x - 1) + c$

(c) $\int 2 \sec^2(8 - 3x) dx = 2 \left[\frac{\tan(8 - 3x)}{-3} \right] + c$ (Note that $\int 2 \sec^2(8 - 3x) dx$
 $= -\frac{2}{3} \tan(8 - 3x) + c$ $\neq -\frac{2}{9} \sec^3(8 - 3x) + c$)

13. Methods of Integrating Trigonometric Functions:

- Use trigonometric identities e.g. $1 + \tan^2 x = \sec^2 x$
- Use double angle formulae e.g. $\cos 2x = 2 \cos^2 x - 1$ or $\cos 2x = 1 - 2 \sin^2 x$

Example 4

Find

(a) $\int 4 \tan^2 3x \, dx$, (b) $\int \sin x \cos x \, dx$,

(c) $\int 6 \cos^2 \frac{x}{2} \, dx$.

Solution

$$\begin{aligned} \text{(a)} \quad \int 4 \tan^2 3x \, dx &= 4 \int (\sec^2 3x - 1) \, dx \\ &= 4 \left[\frac{1}{3} \tan 3x - x \right] + c \\ &= \frac{4}{3} \tan 3x - 4x + c \end{aligned}$$

$$\begin{aligned} \text{(b)} \quad \int \sin x \cos x \, dx &= \frac{1}{2} \int 2 \sin x \cos x \, dx \\ &= \frac{1}{2} \int \sin 2x \, dx \\ &= \frac{1}{2} \left[\frac{-\cos 2x}{2} \right] + c \\ &= -\frac{1}{4} \cos 2x + c \end{aligned}$$

$$\begin{aligned} \text{(c)} \quad \int 6 \cos^2 \frac{x}{2} \, dx &= 3 \int 2 \cos^2 \frac{x}{2} \, dx \\ &= 3 \int (\cos x + 1) \, dx \quad (\cos A = 2 \cos^2 \frac{A}{2} - 1) \\ &= 3[\sin x + x] + c \\ &= 3 \sin x + 3x + c \end{aligned}$$

Example 5

Prove that $(2 \cos \theta - \sin \theta)^2 = \frac{3}{2} \cos 2\theta - 2 \sin 2\theta + \frac{5}{2}$.

Hence, find $\int (2 \cos x - \sin x)^2 dx$.

Solution

$$\begin{aligned}\text{LHS} &= (2 \cos \theta - \sin \theta)^2 \\ &= 4 \cos^2 \theta + \sin^2 \theta - 4 \sin \theta \cos \theta \\ &= 4 \left(\frac{1 + \cos 2\theta}{2} \right) + \left(\frac{1 - \cos 2\theta}{2} \right) - 2(2 \sin \theta \cos \theta) \\ &= 2 + 2 \cos 2\theta + \frac{1}{2} - \frac{1}{2} \cos 2\theta - 2 \sin 2\theta \\ &= \frac{3}{2} \cos 2\theta - 2 \sin 2\theta + \frac{5}{2} \\ &= \text{RHS (shown)}\end{aligned}$$

$$\begin{aligned}\int (2 \cos x - \sin x)^2 dx &= \int \left(\frac{3}{2} \cos 2x - 2 \sin 2x + \frac{5}{2} \right) dx \\ &= \frac{3}{2} \frac{\sin 2x}{2} - \frac{(-2 \cos 2x)}{2} + \frac{5}{2} x + c \\ &= \frac{3}{4} \sin 2x + \cos 2x + \frac{5}{2} x + c\end{aligned}$$

Integration of $\frac{1}{ax+b}$

14. $\int \frac{1}{x} dx = \ln|x| + c$

15. $\int \frac{1}{ax+b} dx = \frac{1}{a} \ln|ax+b| + c$

16. In general, $\int \frac{f'(x)}{f(x)} dx = \ln|f(x)| + c$

Example 6

Find

(a) $\int \frac{5}{3x+5} dx,$

(b) $\int \frac{4}{2-3x} dx,$

(c) $\int \frac{4x^2 + 3x^4}{2x^3} dx.$

Solution

(a) $\int \frac{5}{3x+5} dx = 5 \int \frac{1}{3x+5} dx$

$$= \frac{5}{3} \int \frac{3}{3x+5} dx$$

$$= \frac{5}{3} \ln(3x+5) + c$$

(Manipulate the expression to obtain one in the form $\frac{f'(x)}{f(x)}$.)

(b) $\int \frac{4}{2-3x} dx = 4 \int \frac{1}{2-3x} dx$

$$= \frac{4}{-3} \int \frac{-3}{2-3x} dx$$

$$= -\frac{4}{3} \ln(2-3x) + c$$

(c) $\int \frac{4x^2 + 3x^4}{2x^3} dx = \int \left(\frac{4x^2}{2x^3} + \frac{3x^4}{2x^3} \right) dx$

$$= \int \left(\frac{2}{x} + \frac{3}{2}x \right) dx$$

$$= 2 \ln x + \frac{3}{4}x^2 + c$$

Example 7

Express $\frac{2x+4}{(x+1)(x-2)}$ in partial fractions. Hence, find $\int \frac{2x+4}{(x+1)(x-2)} dx$.

Solution

$$\text{Let } \frac{2x+4}{(x+1)(x-2)} = \frac{A}{x+1} + \frac{B}{x-2}.$$

By Cover-Up Rule,

$$A = -\frac{2}{3} \text{ and } B = \frac{8}{3}$$

$$\frac{2x+4}{(x+1)(x-2)} = -\frac{2}{3(x+1)} + \frac{8}{3(x-2)}$$

$$\begin{aligned} \int \frac{2x+4}{(x+1)(x-2)} dx &= \int \left[-\frac{2}{3(x+1)} + \frac{8}{3(x-2)} \right] dx \\ &= -\frac{2}{3} \ln(x+1) + \frac{8}{3} \ln(x-2) + c \end{aligned}$$



PapaCambridge

Example 8

Find $\int \frac{x+15}{(x-2)(x+3)} dx$.

Solution

Let $\frac{x+15}{(x-2)(x+3)} = \frac{A}{x-2} + \frac{B}{x+3}$.

By Cover-up Rule,

$$A = \frac{17}{5} \text{ and } B = -\frac{12}{5}$$

$$\frac{x+15}{(x-2)(x+3)} = \frac{17}{5(x-2)} - \frac{12}{5(x+3)}$$

$$\begin{aligned} \int \frac{x+15}{(x-2)(x+3)} dx &= \int \left[\frac{17}{5(x-2)} - \frac{12}{5(x+3)} \right] dx \\ &= \frac{17}{5} \ln(x-2) - \frac{12}{5} \ln(x+3) + c \end{aligned}$$

Integration of e^x

17. $\int e^x dx = e^x + c$

18. $\int e^{ax+b} dx = \frac{1}{a} e^{ax+b} + c$



Example 9

Find

(a) $\int e^{3x} dx,$

(b) $\int e^{2x+3} dx,$

(c) $\int 6e^{\frac{x}{3}} dx,$

(d) $\int \frac{e^{3x-1} - 4}{2e^x} dx.$

Solution

(a) $\int e^{3x} dx = \frac{1}{3}e^{3x} + c$

(b) $\int e^{2x+3} dx = \frac{1}{2}e^{2x+3} + c$

(c) $\int 6e^{\frac{x}{3}} dx = \frac{6e^{\frac{x}{3}}}{\frac{1}{3}}$

$$= 18e^{\frac{x}{3}} + c$$

(d) $\int \frac{e^{3x-1} - 4}{2e^x} dx = \int \left(\frac{e^{3x-1}}{2e^x} - \frac{4}{2e^x} \right) dx$

$$= \int \left(\frac{1}{2}e^{2x-1} - 2e^{-x} \right) dx$$

$$= \frac{1}{2}e^{2x-1} - \frac{2e^{-x}}{-1} + c$$

$$= \frac{1}{4}e^{2x-1} + \frac{2}{e^x} + c$$

Definite Integrals

$$1. \int_a^b f(x) dx = [F(x)]_a^b = F(b) - F(a)$$

$$2. \int_a^a f(x) dx = 0$$

$$3. \int_a^b f(x) dx = - \int_b^a f(x) dx$$

$$4. \int_a^b cf(x) dx = c \int_a^b f(x) dx$$

$$5. \int_a^c f(x) dx = \int_a^b f(x) dx + \int_b^c f(x) dx$$

$$6. \int_a^b f(x) \pm g(x) dx = \int_a^b f(x) dx \pm \int_a^b g(x) dx$$



Example 1

Evaluate

$$(a) \int_1^3 \left(x^2 - \frac{10}{x^2} + 3 \right) dx$$

$$(b) \int_1^4 \sqrt{5x-4} \, dx$$

Solution

$$\begin{aligned}(a) \int_1^3 \left(x^2 - \frac{10}{x^2} + 3 \right) dx &= \int_1^3 (x^2 - 10x^{-2} + 3) dx \\ &= \left[\frac{1}{3}x^3 + 10x^{-1} + 3x \right]_1^3 \\ &= \left[\frac{1}{3}x^3 + \frac{10}{x} + 3x \right]_1^3 \\ &= \left[9 + \frac{10}{3} + 9 \right] - \left[\frac{1}{3} + 10 + 3 \right] \\ &= 8\end{aligned}$$

$$\begin{aligned}(b) \int_1^4 \sqrt{5x-4} \, dx &= \int_1^4 (5x-4)^{\frac{1}{2}} dx \\ &= \left[\frac{(5x-4)^{\frac{3}{2}}}{\left(\frac{3}{2}\right)(5)} \right]_1^4 \\ &= \frac{2}{15} \left[(5x-4)^{\frac{3}{2}} \right]_1^4 \\ &= \frac{2}{15} \left[16^{\frac{3}{2}} - 1^{\frac{3}{2}} \right] \\ &= \frac{42}{5}\end{aligned}$$

Example 2

Given that $\int_1^5 f(x) dx = 10$, find the value of each of the following.

(i) $\int_5^1 f(x) dx$ (ii) $\int_1^5 2f(x) dx$

(iii) $\int_1^4 [f(x) + 3\sqrt{x}] dx + \int_4^5 f(x) dx$

Solution

(i) $\int_5^1 f(x) dx = -10$

(ii) $\int_1^5 2f(x) dx = 2 \int_1^5 f(x) dx$
 $= 2(10)$
 $= 20$

(iii) $\int_1^4 [f(x) + 3\sqrt{x}] dx + \int_4^5 f(x) dx = \int_1^4 f(x) dx + 3 \int_1^4 x^{\frac{1}{2}} dx + \int_4^5 f(x) dx$
 $= \int_1^5 f(x) dx + 3 \left[\frac{x^{\frac{3}{2}}}{\frac{3}{2}} \right]_1^4$
 $= 10 + 2 \left[x^{\frac{3}{2}} \right]_1^4$
 $= 10 + 2 \left[4^{\frac{3}{2}} - 1^{\frac{3}{2}} \right]$
 $= 24$

Example 3

Find $\frac{d}{dx}\left(\frac{1}{9-2x^2}\right)$ and hence find the value of $\int_1^2 \frac{12x}{(9-2x^2)^2} dx$.

Solution

$$\begin{aligned}\frac{d}{dx}\left(\frac{1}{9-2x^2}\right) &= \frac{(9-2x^2)(0) - 1(-4x)}{(9-2x^2)^2} \\ &= \frac{4x}{(9-2x^2)^2}\end{aligned}$$

$$\begin{aligned}\int_1^2 \frac{12x}{(9-2x^2)^2} dx &= 3 \int_1^2 \frac{4x}{(9-2x^2)^2} dx \quad (\text{Make use of the answer in the first part of the question.}) \\ &= 3 \left[\frac{1}{9-2x^2} \right]_1^2 \\ &= 3 \left[\frac{1}{1} - \frac{1}{7} \right] \\ &= \frac{18}{7}\end{aligned}$$

Example 4

Evaluate each of the following.

(a) $\int_0^{\frac{\pi}{3}} 3 \sin 3x \, dx$

(b) $\int_0^{\frac{\pi}{4}} (\sec^2 x + 2 \cos x) \, dx$

Solution

(a)
$$\begin{aligned}\int_0^{\frac{\pi}{3}} 3 \sin 3x \, dx &= 3 \left[\frac{-\cos 3x}{3} \right]_0^{\frac{\pi}{3}} \\ &= -[\cos 3x]_0^{\frac{\pi}{3}} \\ &= -[\cos \pi - \cos 0] \\ &= -[-1 - 1] \\ &= 2\end{aligned}$$

$$\begin{aligned}
 \text{(b)} \quad \int_0^{\frac{\pi}{4}} (\sec^2 x + 2 \cos x) \, dx &= [\tan x + 2 \sin x]_0^{\frac{\pi}{4}} \\
 &= \left[\tan \frac{\pi}{4} + 2 \sin \frac{\pi}{4} \right] - [\tan 0 + 2 \sin 0] \\
 &= 1 + \sqrt{2}
 \end{aligned}$$

Area bounded by the x -axis

7. For a region above the x -axis:

Area bounded by the curve $y = f(x)$, the lines $x = a$ and $x = b$ and the x -axis is

$$\int_a^b f(x) \, dx.$$

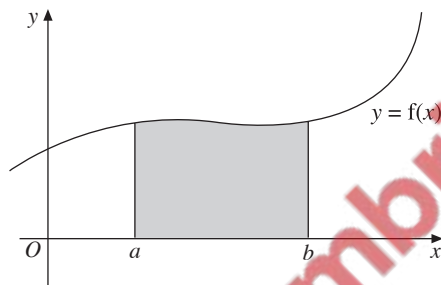

8. For a region below the x -axis:

Area bounded by the curve $y = f(x)$, the lines $x = a$ and $x = b$ and the x -axis is

$$\left| \int_a^b f(x) \, dx \right|.$$

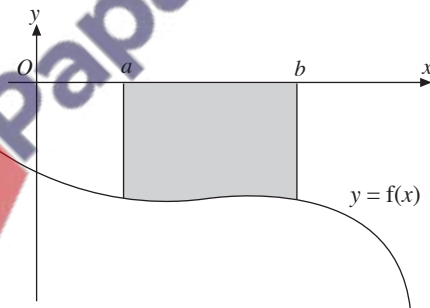

Example 5

Find the area of the shaded region bounded by the curve $y = 2x^3$, the x -axis and the lines $x = 1$ and $x = 3$.

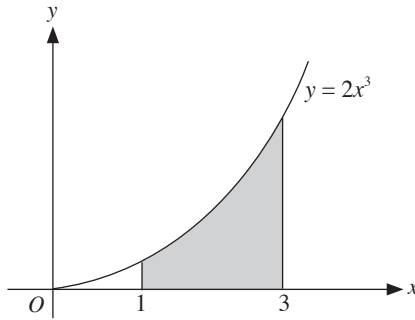

Solution

$$\begin{aligned}\text{Area of shaded region} &= \int_1^3 y \, dx \\ &= \int_1^3 2x^3 \, dx \\ &= \left[\frac{1}{2}x^4 \right]_1^3 \\ &= \frac{1}{2} [3^4 - 1^4] \\ &= 40 \text{ units}^2\end{aligned}$$



Example 6

The figure shows part of the curve $y = (x - 2)(x - 5)$. Find the area of the shaded region.

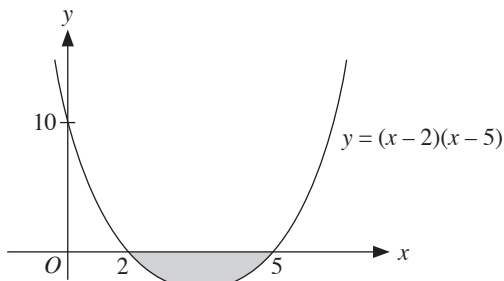

Solution

$$\begin{aligned}\int_2^5 (x-2)(x-5) dx &= \left| \int_2^5 (x^2 - 7x + 10) dx \right| \\ &= \left| \left[\frac{x^3}{3} - \frac{7x^2}{2} + 10x \right]_2^5 \right| \\ &= \left| \left[\frac{5^3}{3} - \frac{7(5)^2}{2} + 10(5) \right] - \left[\frac{2^3}{3} - \frac{7(2)^2}{2} + 10(2) \right] \right| \\ &= 4.5 \text{ units}^2\end{aligned}$$

9. For an area enclosed above and below the x -axis:

Area bounded by the curve $y = f(x)$ and the x -axis as shown below is

$$\int_a^b f(x) dx + \left| \int_b^c f(x) dx \right|$$

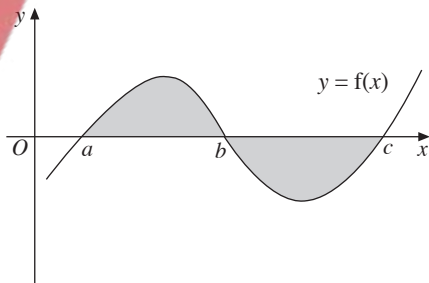

Example 7

The diagram shows part of the curve $y = (x - 1)(x - 2)$.
Find the area bounded by the curve and the x -axis.

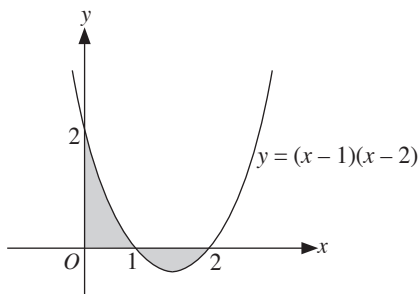

Solution

$$\begin{aligned}
 \text{Area of shaded region} &= \int_0^1 (x-1)(x-2) \, dx + \left| \int_1^2 (x-1)(x-2) \, dx \right| \\
 &= \int_0^1 (x^2 - 3x + 2) \, dx + \left| \int_1^2 (x^2 - 3x + 2) \, dx \right| \\
 &= \left[\frac{1}{3}x^3 - \frac{3}{2}x^2 + 2x \right]_0^1 + \left| \left[\frac{1}{3}x^3 - \frac{3}{2}x^2 + 2x \right]_1^2 \right| \\
 &= \left[\frac{5}{6} - 0 \right] + \left| \frac{2}{3} - \frac{5}{6} \right| \\
 &= 1 \text{ unit}^2
 \end{aligned}$$

Area bounded by the y -axis

10. For a region on the right side of the y -axis:

Area bounded by the curve $x = f(y)$, the lines $y = a$ and $y = b$ and the y -axis is

$$\int_a^b f(y) \, dy.$$

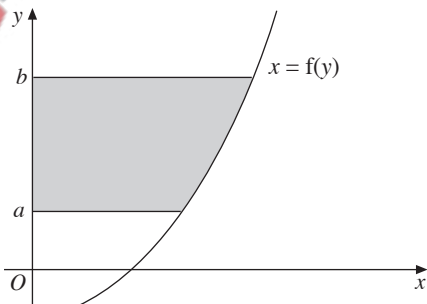

Example 8

The figure shows part of the curve $y = x^3$. Find the area of the shaded region.

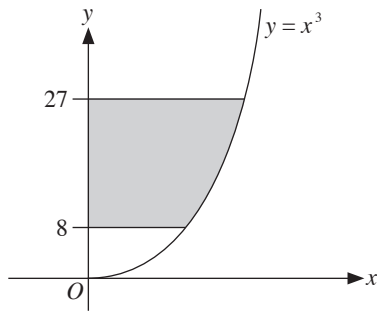

Solution

$$y = x^3$$

$$x = \sqrt[3]{y}$$

$$= y^{\frac{1}{3}}$$

$$\begin{aligned} \text{Area of shaded region} &= \int_8^{27} x \, dy \\ &= \int_8^{27} y^{\frac{1}{3}} \, dy \\ &= \left[\frac{4}{3} y^{\frac{4}{3}} \right]_8^{27} \\ &= \left[\frac{3}{4} (\sqrt[3]{y})^4 \right]_8^{27} \\ &= \frac{3}{4} [81 - 16] \\ &= 48.75 \text{ units}^2 \end{aligned}$$

11. For a region on the left side of the y-axis:

Area bounded by the curve $x = f(y)$, the lines $y = a$ and $y = b$ and the y-axis is

$$\left| \int_a^b f(y) dy \right|.$$

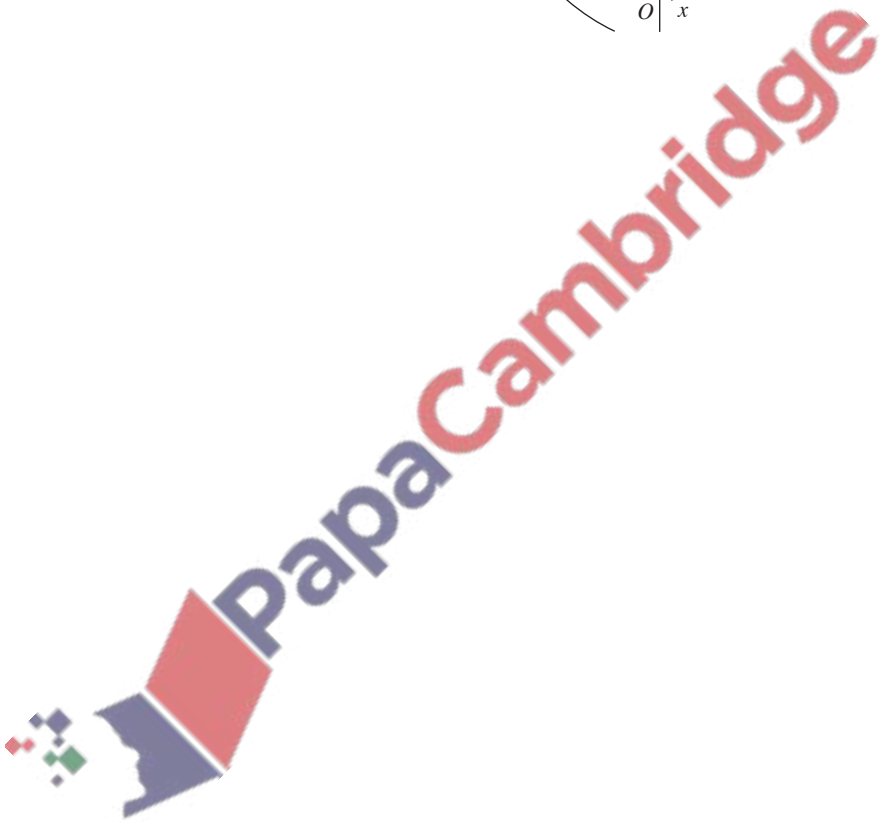
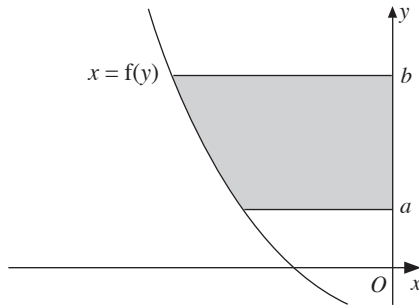

Example 9

Calculate the area of the shaded region shown in the figure.

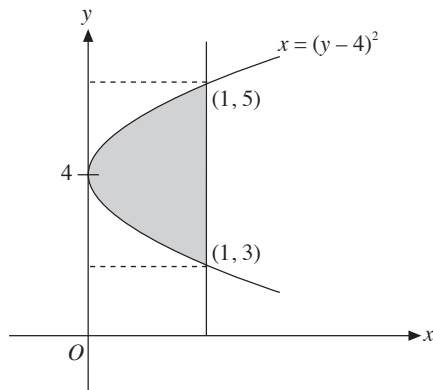

Solution

$$\text{Area of (P + Q)} = \int_3^5 (y - 4)^2 dy$$

$$= \left[\frac{(y - 4)^3}{3} \right]_3^5$$

$$= \frac{1}{3} - \left(-\frac{1}{3} \right)$$

$$= \frac{2}{3} \text{ units}^2$$

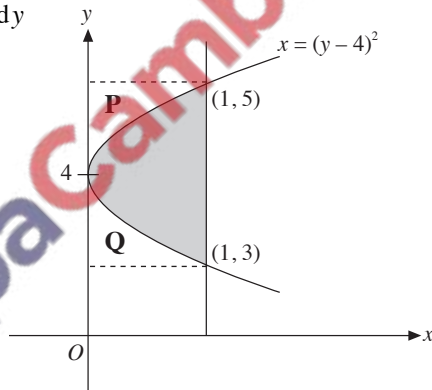

Area of shaded region = Area of rectangle – Area of (P + Q)

$$= (1)(2) - \frac{2}{3}$$

$$= \frac{4}{3} \text{ units}^2$$

Example 10

The diagram shows the curve $y = x^2 - 4$. It cuts the line $y = 5$ at $P(3, 5)$. The line $x = 4$ intersects the curve at $R(4, 16)$. Find the area of the shaded region PQR .

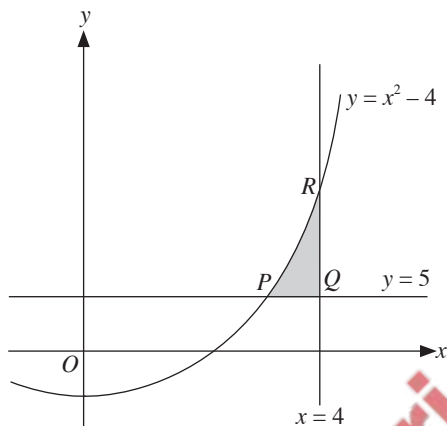

Solution

$$\begin{aligned}\text{Area of } PQR &= \int_3^4 [(x^2 - 4) - 5] dx \\ &= \int_3^4 (x^2 - 9) dx \\ &= \left[\frac{1}{3}x^3 - 9x \right]_3^4 \\ &= \left[-\frac{44}{3} - (-18) \right] \\ &= 3\frac{1}{3} \text{ units}^2\end{aligned}$$

Relationship between Displacement, Velocity and Acceleration

1. Differentiation:

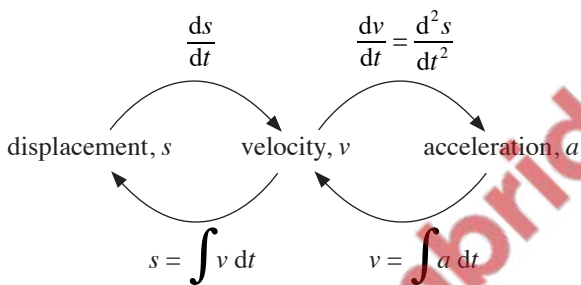

Common Terms used in Kinematics

- Displacement, s , is defined as the distance moved by a particle in a specific direction.
- Velocity, v , is defined as the rate of change of displacement with respect to time. v can take on positive or negative values.
- Acceleration, a , is defined as the rate of change of velocity with respect to time. a can take on positive or negative values.
 When $a > 0$, acceleration occurs.
 When $a < 0$, deceleration occurs.
- | | |
|--------------------------------|---------|
| Initial | $t = 0$ |
| At rest | $v = 0$ |
| Stationary | $v = 0$ |
| Particle is at the fixed point | $s = 0$ |
| Maximum/minimum displacement | $v = 0$ |
| Maximum/minimum velocity | $a = 0$ |

6. Average speed = $\frac{\text{Total distance travelled}}{\text{Total time taken}}$
7. To find the distance travelled in the first n seconds:
Step 1: Let $v = 0$ to find t .
Step 2: Find s for each of the values of t found in step 1.
Step 3: Find s for $t = 0$ and $t = n$.
Step 4: Draw the path of the particle on a displacement-time graph.

Example 1

A particle moves in a straight line in such a way that, t seconds after passing through a fixed point O , its displacement from O is s m. Given that $s = 2 - \frac{4}{t+2}$, find

- (i) expressions, in terms of t , for the velocity and acceleration of the particle,
(ii) the value of t when the velocity of the particle is 0.25 m s^{-1} ,
(iii) the acceleration of the particle when it is 1 m from O .

Solution

(i) $s = 2 - \frac{4}{t+2}$

$$v = \frac{ds}{dt} = \frac{4}{(t+2)^2} \quad (\text{Apply the Chain Rule of Differentiation})$$

$$a = \frac{dv}{dt} = -\frac{8}{(t+2)^3}$$

- (ii) When $v = 0.25$,

$$\frac{4}{(t+2)^2} = 0.25$$

$$(t+2)^2 = 16$$

$$t+2 = \pm 4$$

$$t = 2 \text{ or } t = -6 \text{ (rejected)} \quad (\text{The negative value of } t \text{ is rejected since time cannot be negative.})$$

(iii) When $s = 1$,

$$2 - \frac{4}{t+2} = 1$$

$$\frac{4}{t+2} = 1$$

$$t+2 = 4$$

$$t = 2$$

Substitute $t = 2$ into $a = -\frac{8}{(t+2)^3}$:

$$a = -\frac{8}{(2+2)^3}$$

$$= -\frac{1}{8}$$

\therefore Acceleration of the particle when it is 1 m from O is $-\frac{1}{8} \text{ m s}^{-2}$.

Example 2

A particle moves in a straight line such that its displacement, s m from a fixed point A , is given by $s = 2t + 3 \sin 2t$, where t is the time in seconds after passing point A . Find

- (i) the initial position of the particle,
- (ii) expressions for the velocity and acceleration of the particle in terms of t ,
- (iii) the time at which the particle first comes to rest.

Solution

(i) $s = 2t + 3 \sin 2t$

When $t = 0$, $s = 2(0) + 3 \sin 2(0) = 0$.

\therefore The particle is initially at point A .

(ii) $s = 2t + 3 \sin 2t$

$$v = \frac{ds}{dt}$$

$$= 2 + 6 \cos 2t$$

$$a = \frac{dv}{dt}$$

$$= -12 \sin 2t$$

(iii) When $v = 0$,

$$2 + 6 \cos 2t = 0$$

$$\cos 2t = -\frac{1}{3}$$

$$2t = 1.91 \text{ (to 3 s.f.)}$$

$$t = 0.955$$

Example 3

A stone that was initially at rest was thrown from the ground into the air, rising at a velocity of $v = 40 - 10t$, where t is the time taken in seconds.

(i) Find the maximum height reached by the stone.

(ii) Find the values of t when the particle is 35 m above the ground.

Solution

(i) $s = \int v \, dt$

$$= \int (40 - 10t) \, dt$$

$$= 40t - 5t^2 + c$$

When $t = 0$, $s = 0 \quad \therefore c = 0$

$$s = 40t - 5t^2$$

At maximum height,

$$v = 0 \quad (v = 0 \text{ at maximum displacement.})$$

$$40 - 10t = 0$$

$$t = 4$$

When $t = 4$, $s = 40(4) - 5(4)^2 = 80$.

\therefore The maximum height reached by the stone is 80 m.

(ii) When $s = 35$,

$$40t - 5t^2 = 35$$

$$5t^2 - 40t + 35 = 0$$

$$t^2 - 8t + 7 = 0$$

$$(t - 1)(t - 7) = 0$$

$$t = 1 \quad \text{or} \quad t = 7$$

\therefore The particle is 35 m above the ground when $t = 1$ and $t = 7$.

Example 4

A particle moves in a straight line so that, t seconds after passing through a fixed point O , its velocity, v cm s^{-1} , is given by $v = 8t - 3t^2 + 3$. The particle comes to instantaneous rest at the point P . Find

- (i) the value of t for which the particle is instantaneously at rest,
- (ii) the acceleration of the particle at P ,
- (iii) the distance OP ,
- (iv) the total distance travelled in the time interval $t = 0$ to $t = 4$.

Solution

- (i) When $v = 0$,

$$8t - 3t^2 + 3 = 0$$

$$3t^2 - 8t - 3 = 0$$

$$(3t + 1)(t - 3) = 0$$

$$t = -\frac{1}{3} \text{ (rejected) or } t = 3$$

- (ii) $v = 8t - 3t^2 + 3$

$$a = 8 - 6t$$

$$\text{When } t = 3, a = -10$$

\therefore Acceleration of the particle at P is -10 cm s^{-2} .

- (iii) $s = \int v \, dt$

$$= \int (8t - 3t^2 + 3) \, dt$$

$$= 4t^2 - t^3 + 3t + c$$

$$\text{When } t = 0, s = 0 \quad \therefore c = 0$$

$$\therefore s = 4t^2 - t^3 + 3t$$

$$\text{When } t = 3, s = 18$$

$$\therefore OP = 18 \text{ cm}$$

- (iv) When $t = 0, s = 0$.
 When $t = 3, s = 18$.
 When $t = 4, s = 12$.

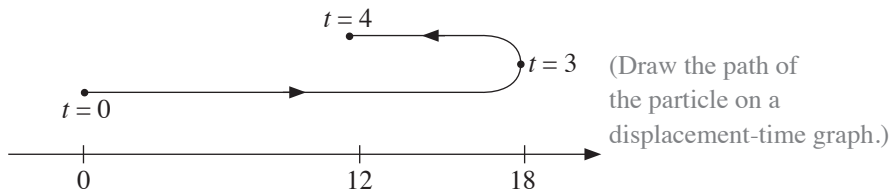

$$\begin{aligned} \therefore \text{Total distance travelled} &= 18 + (18 - 12) \\ &= 24 \text{ cm} \end{aligned}$$

Example 5

A particle moving in a straight line passes a fixed point O with a velocity of 4 m s^{-1} . The acceleration of the particle, $a \text{ m s}^{-2}$, is given by $a = 2t - 5$, where t is the time after passing O . Find

- the values of t when the particle is instantaneously at rest,
- the displacement of the particle when $t = 2$.

Solution

$$\begin{aligned} \text{(i)} \quad v &= \int a \, dt \\ &= \int (2t - 5) \, dt \\ &= t^2 - 5t + c \end{aligned}$$

$$\text{When } t = 0, v = 4 \quad \therefore c = 4$$

$$\therefore v = t^2 - 5t + 4$$

When the particle is instantaneously at rest, $v = 0$.

$$t^2 - 5t + 4 = 0$$

$$(t - 4)(t - 1) = 0$$

$$t = 4 \quad \text{or} \quad t = 1$$

$$\begin{aligned}
 \text{(ii)} \quad s &= \int v \, dt \\
 &= \int (t^2 - 5t + 4) \, dt \\
 &= \frac{1}{3}t^3 - \frac{5}{2}t^2 + 4t + c_1
 \end{aligned}$$

$$\text{When } t = 0, s = 0 \quad \therefore c_1 = 0$$

$$\therefore s = \frac{1}{3}t^3 - \frac{5}{2}t^2 + 4t$$

$$\text{When } t = 2,$$

$$s = \frac{1}{3}(2)^3 - \frac{5}{2}(2)^2 + 4(2)$$

$$= \frac{2}{3}$$

$$\therefore \text{Displacement of the particle is } \frac{2}{3} \text{ m}$$

Example 6

A particle starts at rest from a fixed point O and travels in a straight line so that, t seconds after leaving point O on the line, its acceleration, $a \text{ m s}^{-2}$, is given by $a = 2 \cos t - \sin t$. Find

- (i) the value of t when the particle first comes to an instantaneous rest,
- (ii) the distance travelled by the particle in the first 3 seconds after leaving O .

Solution

$$\text{(i)} \quad a = 2 \cos t - \sin t$$

$$v = \int a \, dt \quad (\text{Recall that when a particle is at instantaneous rest, } v = 0.)$$

$$= \int (2 \cos t - \sin t) \, dt$$

$$= 2 \sin t + \cos t + c$$

$$\text{When } t = 0, v = 0 \quad \therefore c = -1 \quad (\text{Note that } \cos 0 = 1.)$$

$$\therefore v = 2 \sin t + \cos t - 1$$

When $v = 0$,

$$2 \sin t + \cos t - 1 = 0$$

$$2 \sin t + \cos t = 1 \quad (\text{R-formula is needed to solve this equation.})$$

$$\sqrt{5} \sin(t + 0.4636) = 1$$

$$\sin(t + 0.4636) = \frac{1}{\sqrt{5}}$$

basic angle, $\alpha = 0.4636$ (to 4 s.f.)

$$t + 0.4636 = 0.4636, 2.677$$

$$t = 0, 2.21 \text{ (to 3 s.f.)}$$

\therefore The particle first comes to an instantaneous rest when $t = 2.21$.

$$\begin{aligned} \text{(ii) } s &= \int v \, dt \\ &= \int (2 \sin t + \cos t - 1) \, dt \\ &= \sin t - 2 \cos t - t + d \end{aligned}$$

When $t = 0, s = 0 \quad \therefore d = 2$

$$\therefore s = \sin t - 2 \cos t - t + 2$$

When $t = 0, s = 0$.

When $t = 2.214, s = 1.785$.

When $t = 3, s = 1.121$.

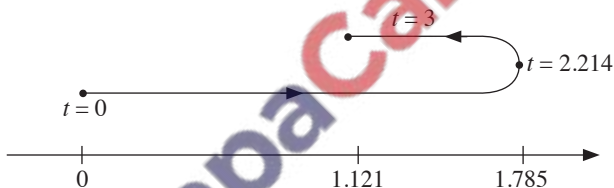

$$\begin{aligned} \therefore \text{Total distance travelled} &= 1.785 + (1.785 - 1.121) \\ &= 2.45 \text{ m (to 3 s.f.)} \end{aligned}$$

MATHEMATICAL FORMULAE

1. ALGEBRA

Quadratic Equation

For the equation $ax^2 + bx + c = 0$,

$$x = \frac{-b \pm \sqrt{b^2 - 4ac}}{2a}$$

Binomial expansion

$$(a + b)^n = a^n + \binom{n}{1}a^{n-1}b + \binom{n}{2}a^{n-2}b^2 + \dots + \binom{n}{r}a^{n-r}b^r + \dots + b^n,$$

where n is a positive integer and $\binom{n}{r} = \frac{n!}{r!(n-r)!} = \frac{n(n-1)\dots(n-r+1)}{r!}$

2. TRIGONOMETRY

Identities

$$\sin^2 A + \cos^2 A = 1$$

$$\sec^2 A = 1 + \tan^2 A$$

$$\operatorname{cosec}^2 A = 1 + \cot^2 A$$

$$\sin(A \pm B) = \sin A \cos B \pm \cos A \sin B$$

$$\cos(A \pm B) = \cos A \cos B \mp \sin A \sin B$$

$$\tan(A \pm B) = \frac{\tan A \pm \tan B}{1 \mp \tan A \tan B}$$

$$\sin 2A = 2 \sin A \cos A$$

$$\cos 2A = \cos^2 A - \sin^2 A = 2\cos^2 A - 1 = 1 - 2\sin^2 A$$

$$\tan 2A = \frac{2 \tan A}{1 - \tan^2 A}$$

Formulae for $\triangle ABC$

$$\frac{a}{\sin A} = \frac{b}{\sin B} = \frac{c}{\sin C}$$
$$a^2 = b^2 + c^2 - 2bc \cos A$$

$$\Delta = \frac{1}{2}bc \sin A$$