



UNIVERSITY OF CAMBRIDGE INTERNATIONAL EXAMINATIONS
General Certificate of Education Ordinary Level

www.PapaCambridge.com

PHYSICS

5054/01

Paper 1 Multiple Choice

October/November 2008

1 hour

Additional Materials: Multiple Choice Answer Sheet
Soft clean eraser
Soft pencil (type B or HB is recommended)

* 9 2 9 3 8 3 2 1 9 2 *

READ THESE INSTRUCTIONS FIRST

Write in soft pencil.

Do not use staples, paper clips, highlighters, glue or correction fluid.

Write your name, Centre number and candidate number on the Answer Sheet in the spaces provided unless this has been done for you.

There are **forty** questions on this paper. Answer **all** questions. For each question there are four possible answers **A, B, C** and **D**.

Choose the **one** you consider correct and record your choice in **soft pencil** on the separate Answer Sheet.

Read the instructions on the Answer Sheet very carefully.

Each correct answer will score one mark. A mark will not be deducted for a wrong answer.
Any rough working should be done in this booklet.

This document consists of **18** printed pages and **2** blank pages.



- 1 A manufacturer needs to measure accurately the dimensions of a wooden floor tile.
The approximate dimensions of the tile are shown.

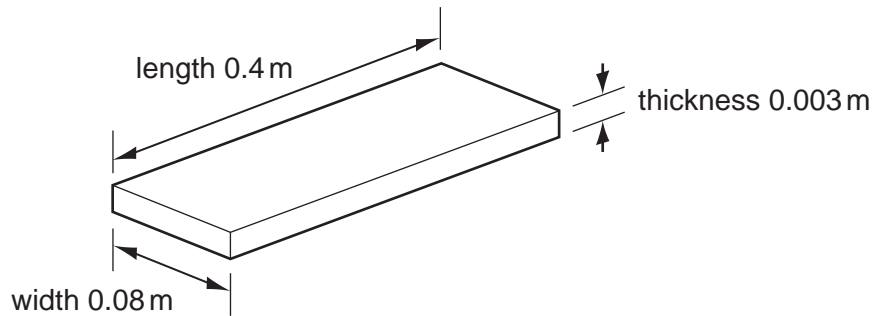

Which instruments measure each of these dimensions accurately?

	length	thickness	width
A	metre rule	micrometer	vernier calipers
B	metre rule	vernier calipers	micrometer
C	micrometer	metre rule	vernier calipers
D	vernier calipers	micrometer	metre rule

- 2 A car takes 1 hour to travel 100 km along a main road and then $\frac{1}{2}$ hour to travel 20 km along a side road.

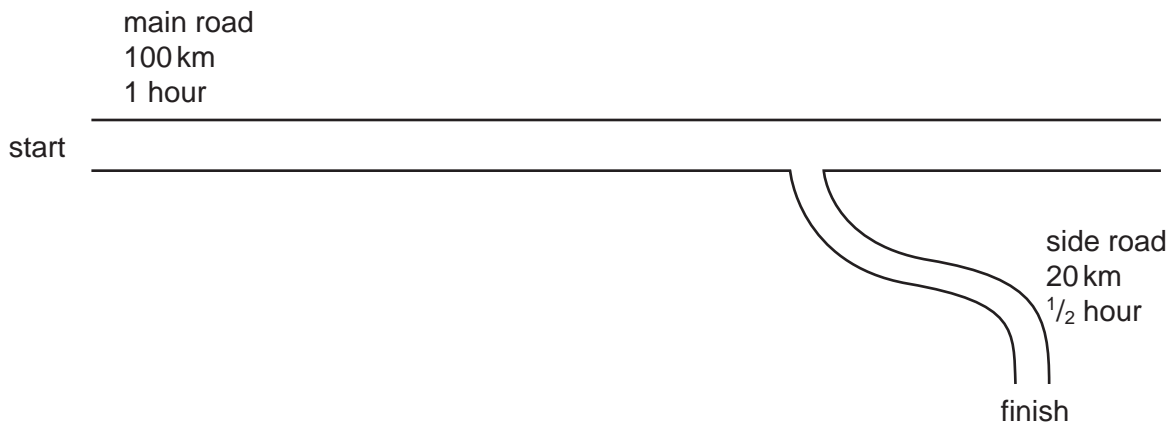

What is the average speed of the car for the whole journey?

- A** 60 km/h **B** 70 km/h **C** 80 km/h **D** 100 km/h

- 3 How is the motion of a body affected by balanced and unbalanced forces acting on it?

	balanced forces	unbalanced forces
A	velocity changes	velocity changes
B	velocity changes	velocity constant
C	velocity constant	velocity changes
D	velocity constant	velocity constant

- 4 The diagram represents the Moon in its orbit around the Earth.

Which arrow represents the direction of the resultant force acting on the Moon at the instant shown?

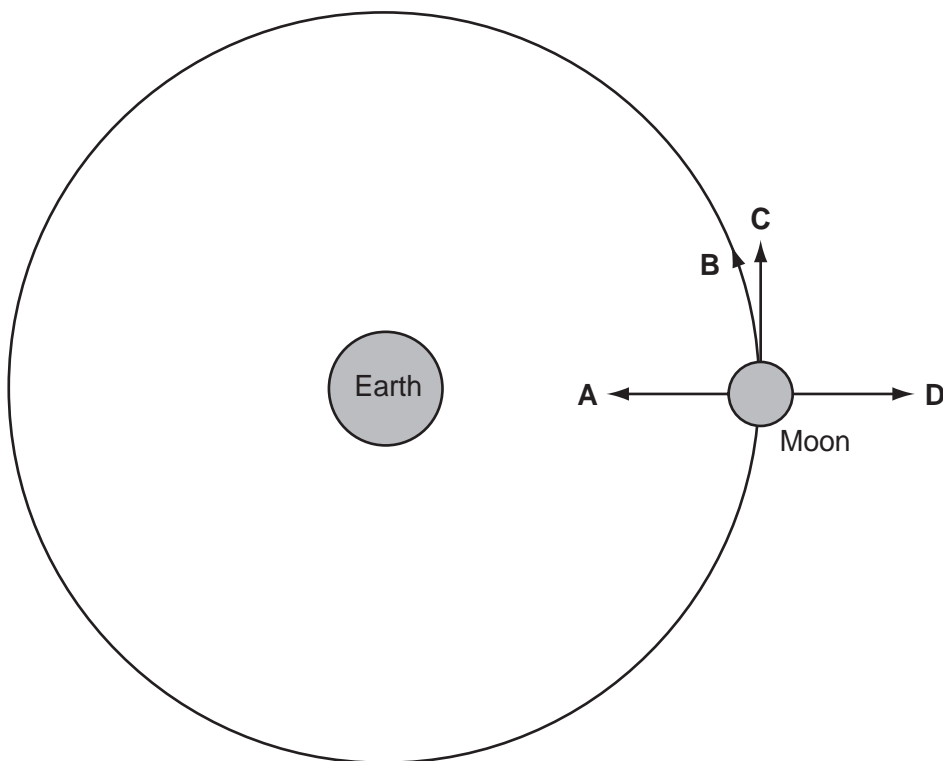

- 5 The diagram shows two objects on a beam balance in equilibrium.

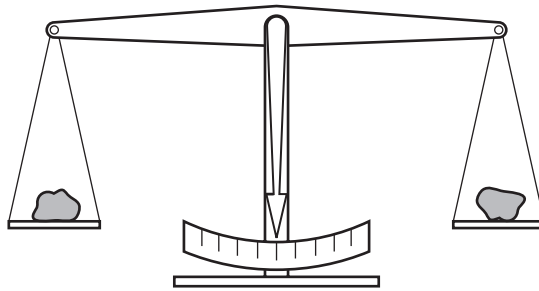

Which need not be the same?

- A** the masses of the two objects
B the moments about the pivot of the two objects
C the volumes of the two objects
D the weights of the two objects
- 6 The mass of a measuring cylinder is measured before and after pouring a liquid into it.

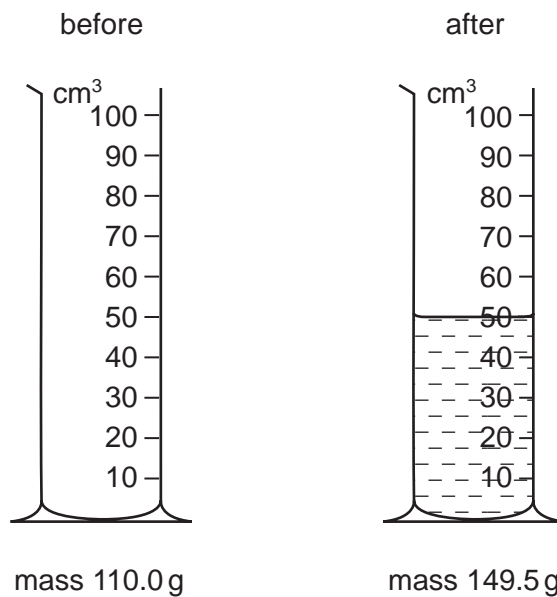

What is the density of the liquid?

- A** 0.79g/cm^3 **B** 1.3g/cm^3 **C** 1.4g/cm^3 **D** 2.2g/cm^3

- 7 The diagram shows a uniform half-metre rule balanced at its mid-point.

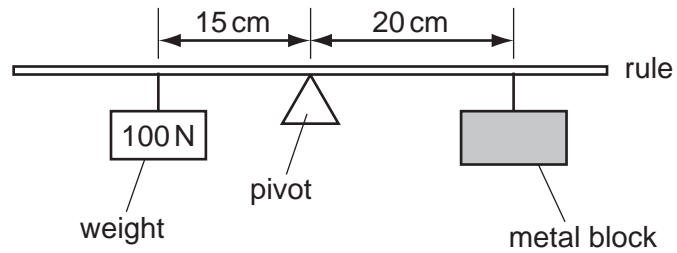

What is the weight of the metal block?

- A** 50 N **B** 75 N **C** 100 N **D** 150 N
- 8 A piece of uniform card is suspended freely from a horizontal pin.
- At which of the points shown is its centre of gravity?

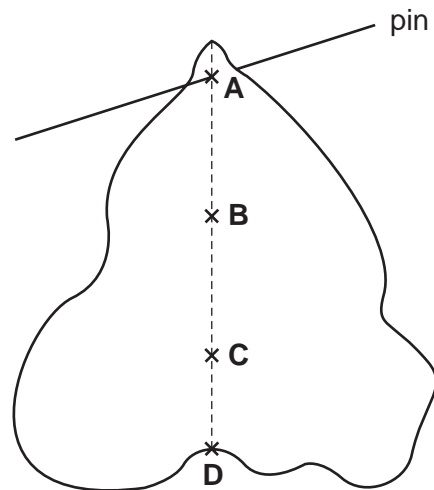

- 9 A single spring is loaded with a 1 N weight. The load is then increased to 2 N and the extension increases by 1.0 cm, as shown.

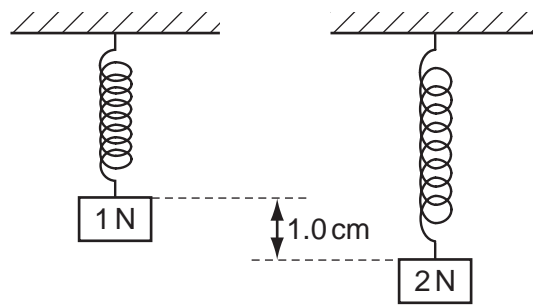

Two springs that are identical to the first one are put side by side. They are connected at both ends, and a 1 N weight is hung on them. The load is then increased to 2 N.

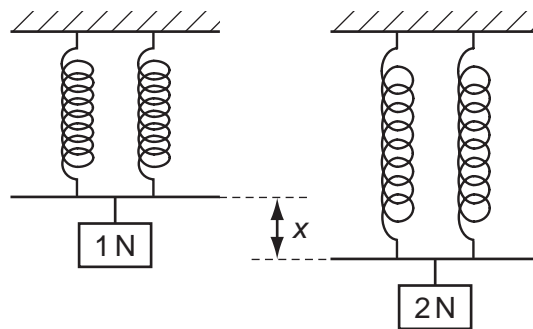

What is the new increase x in the extension?

- A 0.5 cm B 1.0 cm C 2.0 cm D 3.0 cm
- 10 The graph shows how the height above the ground of a bouncing ball changes with time.

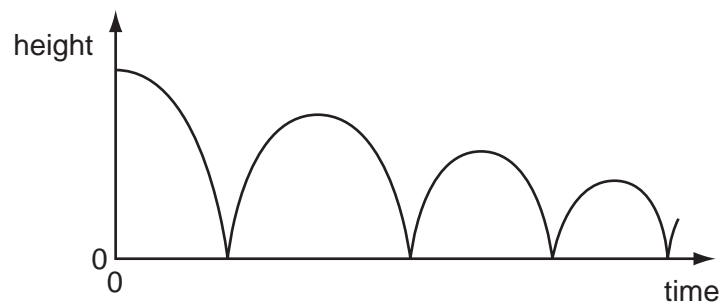

Which statement explains why the height of each peak decreases with time?

- A Kinetic energy is converted to potential energy at each bounce.
 B Kinetic energy is converted to thermal energy at each bounce.
 C The ball gains energy on impact with the floor.
 D The ball is wearing out.

- 11 Where is energy released by the fusion of hydrogen atoms to form helium?
- A in a nuclear power station
 B in a radioactive isotope
 C in the core of the Earth
 D in the core of the Sun
- 12 A crane lifts a weight of 1000 N through a vertical height of 30 m.
 It uses 60 000 J of energy.
 What is the efficiency of the crane?
- A 20% B 30% C 40% D 50%
- 13 A rock climber of weight 600 N climbs up a rock face of vertical height 300 m in 3600 s.
 What is the average power she generates against gravity during this time?
- A 0.020 W B 50 W C 1800 W D 7200 W
- 14 The diagram shows a simple manometer.

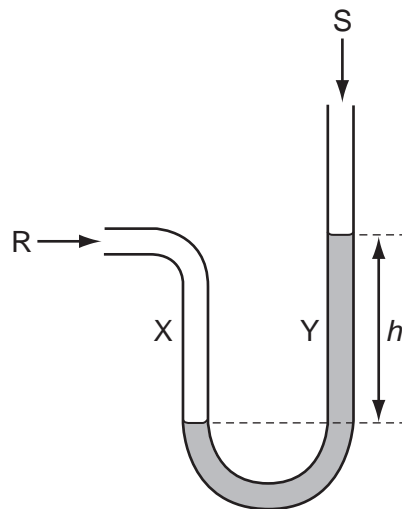

Side X is connected to a gas supply. Side Y is open to the atmosphere.

What pressure is the length h used to measure?

- A the atmospheric pressure S
 B the difference between the gas pressure R and the atmospheric pressure S
 C the gas pressure R
 D the sum of the gas pressure R and the atmospheric pressure S

15 The diagram shows the principle of an hydraulic system.

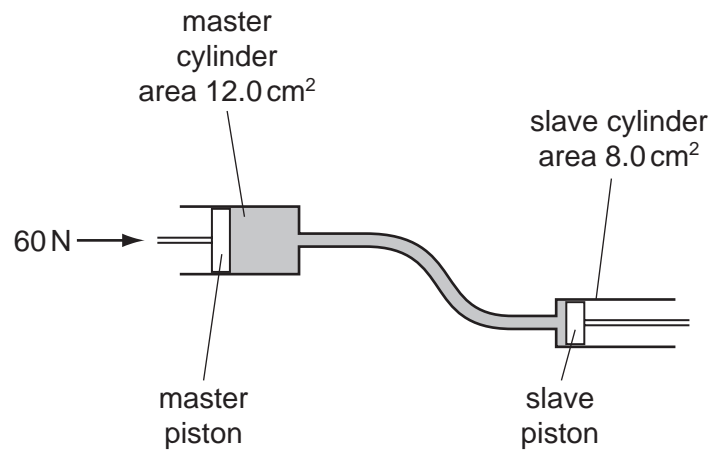

The cross-sectional area of the master cylinder is 12.0 cm^2 and the cross-sectional area of the slave cylinder is 8.0 cm^2 . The force applied to the master piston is 60 N , producing a pressure of 5.0 N/cm^2 .

Which line in the table is correct?

	<u>pressure at slave cylinder</u> N/cm^2	<u>force at slave cylinder</u> N
A	3.3	40
B	3.3	90
C	5.0	40
D	5.0	90

- 16 A student needs a double-walled glass vessel to contain a hot liquid.

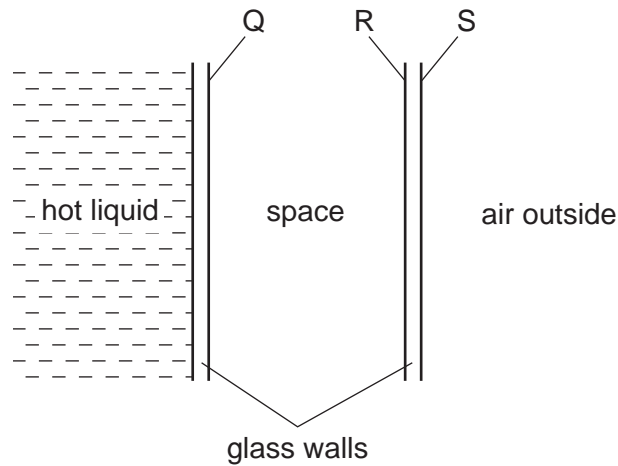

What reduces heat losses by radiation?

- A a vacuum in the space between the walls
 - B painting surface Q black
 - C painting surface R black
 - D painting surface S silver
- 17 A thermocouple thermometer is made from two wires connected to a voltmeter.

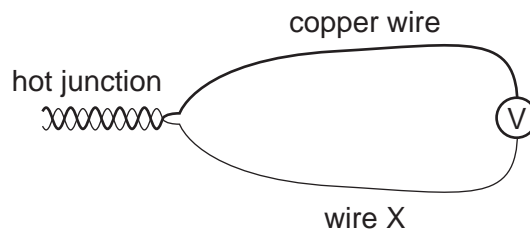

Which arrangement gives a reading on the voltmeter?

	temperature of voltmeter	wire X
A	colder than hot junction	copper
B	colder than hot junction	iron
C	same as hot junction	copper
D	same as hot junction	iron

- 18 Using an electric kettle, 100 g of water at 100 °C is converted into steam at 100 °C in 300 s. The specific latent heat of steam is 2250 J/g.

What is the average electrical power used?

- A $\frac{2250}{300 \times 100}$ W
- B $\frac{100 \times 2250}{300}$ W
- C $\frac{300 \times 2250}{100}$ W
- D $100 \times 300 \times 2250$ W
- 19 The table shows the increase in length of four metals when heated through the same temperature rise. Each metal initially has the same length.

metal	increase in length / m
aluminium	0.000030
copper	0.000020
platinum	0.000009
steel	0.000010

A bimetallic strip is made from two of the metals. When heated, it bends in the direction shown.

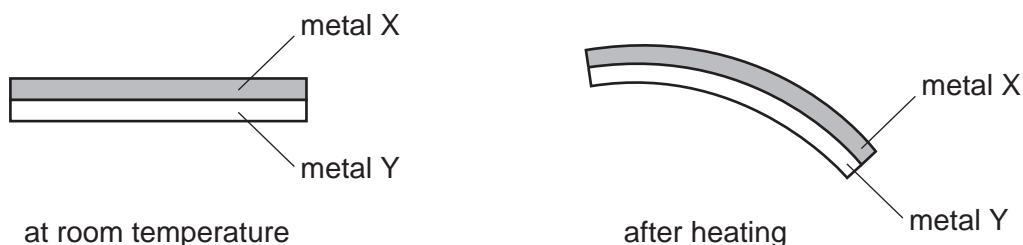

Which metals produce the above effect?

	metal X	metal Y
A	aluminium	platinum
B	copper	aluminium
C	steel	copper
D	platinum	steel

20 When ice melts to become water, which force must be overcome?

- A the attraction between electrons and the nucleus
- B the attraction between the atoms in a molecule
- C the force between molecules
- D the force of gravity

21 Which factors increase the rate of evaporation of a liquid?

	increasing its temperature	increasing its surface area	increasing its depth
A	yes	yes	yes
B	yes	yes	no
C	yes	no	yes
D	no	yes	yes

22 The diagram shows the refraction of water waves in a ripple tank. The water is shallower above the glass sheet.

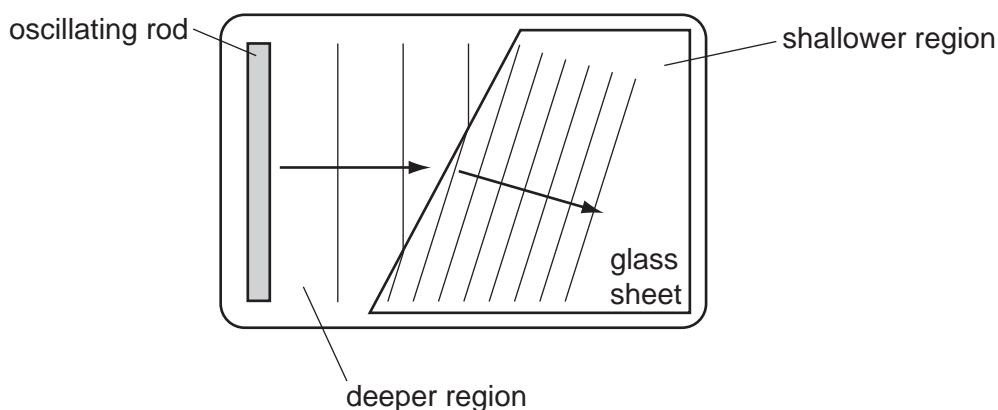

When crossing into the shallower region, what is the effect on the frequency and on the speed of the waves?

	wave frequency	wave speed
A	changes	changes
B	changes	unchanged
C	unchanged	changes
D	unchanged	unchanged

23 An eye views an object O by reflection in a plane mirror.

Which is the correct ray diagram?

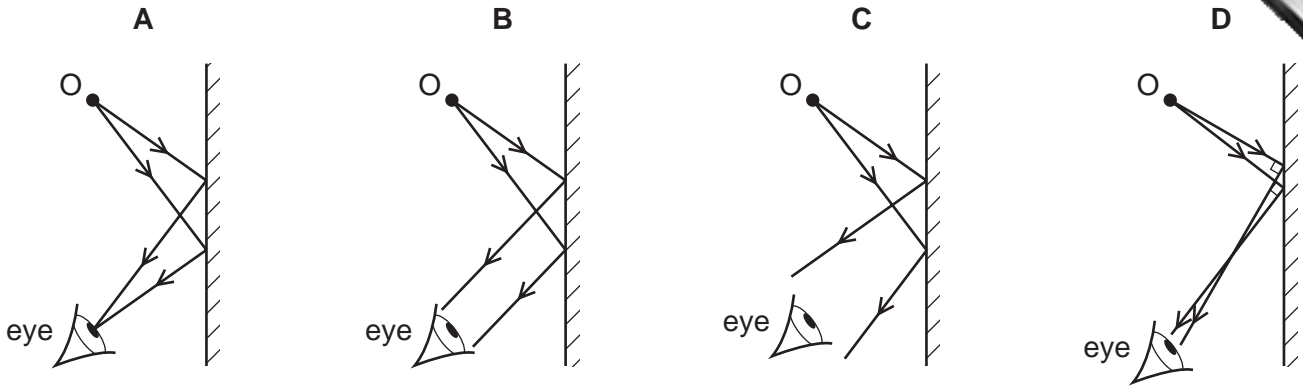

24 A ray of light enters a glass block at an angle of incidence i producing an angle of refraction r in the glass.

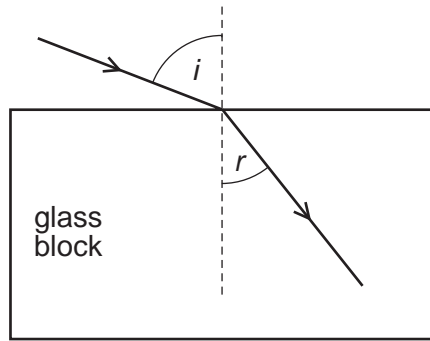

Several different values of i and r are measured, and a graph is drawn of $\sin i$ against $\sin r$.

Which graph is correct?

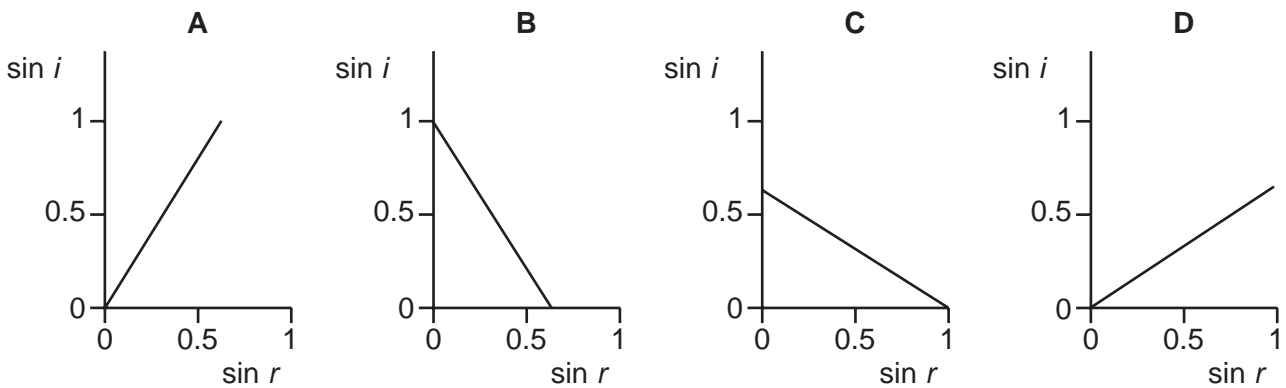

- 25 In a short-sighted eye, rays from distant objects are not focused on the retina.

Where are these rays focused and what type of lens is needed to correct the problem?

	where focused	lens needed
A	behind the retina	converging lens
B	behind the retina	diverging lens
C	in front of the retina	converging lens
D	in front of the retina	diverging lens

- 26 Delicate instruments are often placed in a 'box' to protect them from stray magnetic fields.

What is the material used for the box and why is it chosen?

- A** Aluminium is used because it is a non-magnetic material.
- B** Copper is used because it has a low electrical resistance.
- C** Polythene is used because it is a good electrical insulator.
- D** Soft iron is used because it is a magnetic material.
- 27 A piece of polythene is rubbed with a cloth duster. The polythene becomes negatively charged and the cloth becomes positively charged.

What happens to the polythene and to the cloth to cause this?

	polythene	cloth
A	gains electrons	gains protons
B	gains electrons	loses electrons
C	loses protons	gains protons
D	loses protons	loses electrons

- 28 The current in an electric heater is 10 A. It is switched on for five minutes.

How much charge flows through the heater?

- A** 0.5 C **B** 2 C **C** 50 C **D** 3000 C

29 Which graph shows how the current changes when the voltage across a fixed resistor is varied?

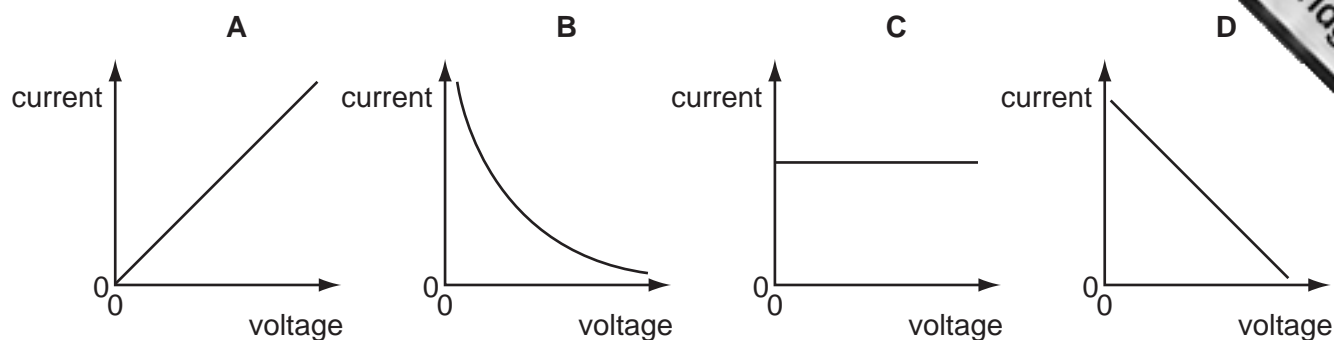

30 The circuit diagram shows a parallel arrangement of resistors.

P, Q, R and S represent the current at the points shown.

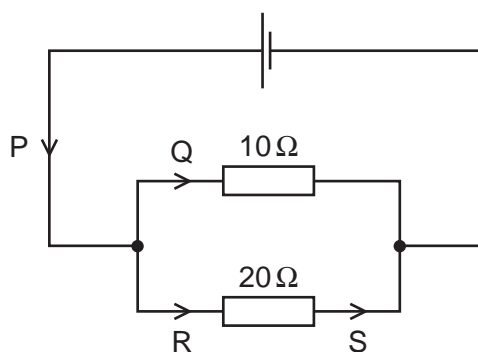

Which statement is correct?

- A P is greater than Q.
- B Q is equal to R.
- C R is greater than S.
- D S is equal to P.

31 An electric heater is rated at 3 kW. Electrical energy costs 20 cents per kWh.

What is the cost of using the heater for five hours?

- A 12 cents
- B 60 cents
- C 100 cents
- D 300 cents

32 What is the purpose of a circuit breaker in an electric circuit?

- A to change alternating current into direct current
- B to keep the current constant
- C to prevent the current from becoming too large
- D to reduce the current to a safe value

- 33 Each of the diagrams is a cross-section through two parallel, current-carrying conductors. Which diagram shows correctly the magnetic field pattern **and** the directions of the forces between the two conductors?

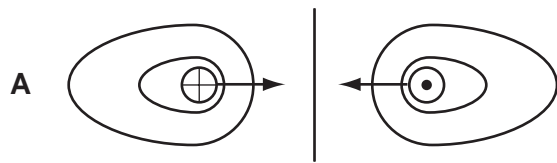

key

⊕ conductor carrying current into page

⊙ conductor carrying current out of page

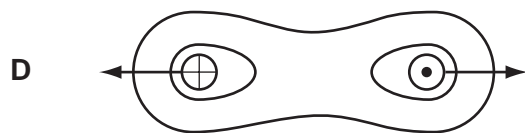
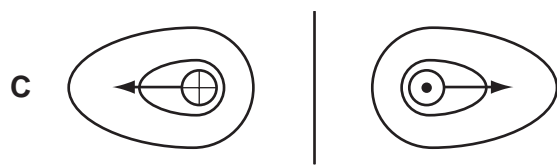
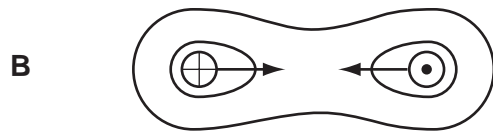

- 34 The e.m.f. induced in a conductor moving at right-angles to a magnetic field does **not** depend upon
- A** the length of the conductor.
 - B** the resistance of the conductor.
 - C** the speed of the conductor.
 - D** the strength of the magnetic field.

35 Which diagram shows how the voltage output of a simple a.c. generator varies with time?

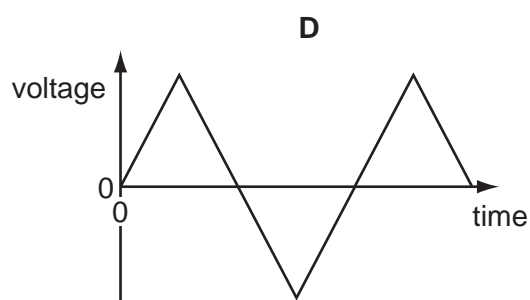
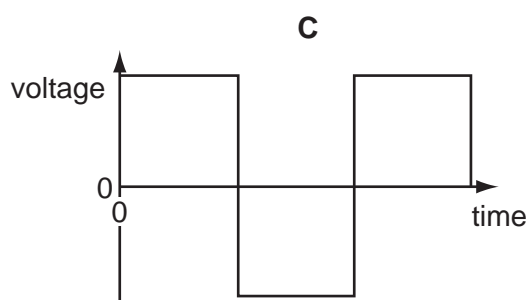
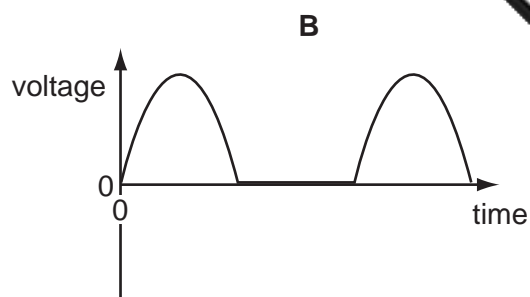
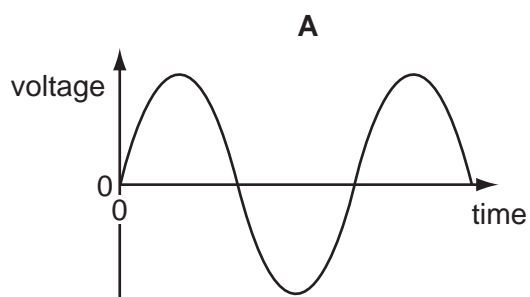

36 The diagram shows a working transformer.

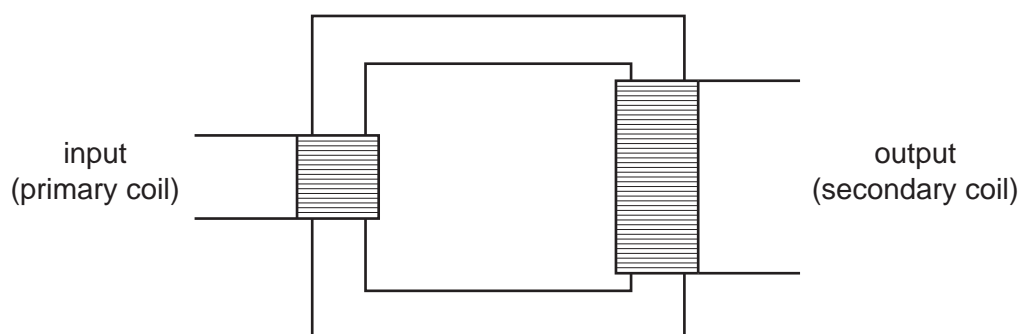

Which statement is correct?

- A** The input voltage is d.c.
- B** The input voltage is greater than the output voltage.
- C** The input voltage is less than the output voltage.
- D** The input voltage is the same as the output voltage.

- 37 The electric circuit shown is used to study the charging of capacitor C.

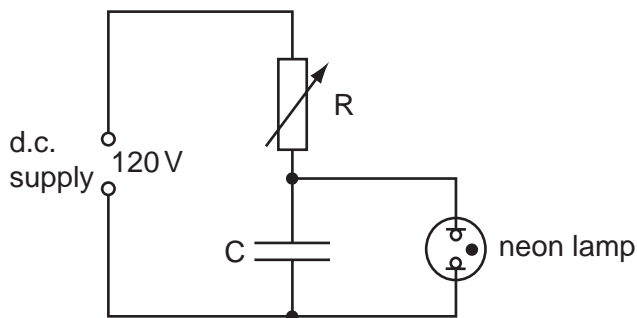

The neon lamp lights when the p.d. across the capacitor C reaches 110 V. C then discharges through the neon lamp. When C has discharged, the lamp goes out and the p.d. across C slowly increases once more.

What is the effect of increasing the resistance of R?

- A** The lamp lights up and goes out at the same rate.
B The lamp lights up and goes out less frequently.
C The lamp lights up and goes out more frequently.
D The lamp will not go out at all.
- 38 What occurs in the decay of a radioactive nucleus?
- A** The nucleus absorbs another nucleus.
B The nucleus absorbs at least one form of radiation.
C The nucleus always splits into two equal fragments.
D The nucleus emits at least one form of radiation.
- 39 The radioactive nucleus ${}_{37}^{87}\text{Rb}$ decays with the emission of a beta-particle.

How many protons and neutrons are left in the nucleus?

	protons	neutrons
A	37	49
B	37	50
C	38	49
D	38	87

40 A narrow beam of alpha-particles is fired at a thin piece of gold foil.

Which is the final direction of the largest number of alpha-particles?

