



UNIVERSITY OF CAMBRIDGE INTERNATIONAL EXAMINATIONS
General Certificate of Education Ordinary Level

www.PapaCambridge.com

PHYSICS

5054/31

Paper 3 Practical Test

October/November 2011

CONFIDENTIAL INSTRUCTIONS

Great care should be taken to ensure that any confidential information given does not reach the candidates either directly or indirectly.

No access to the Question Paper is permitted in advance of the examination.



If you have any problems or queries regarding these Instructions, please contact CIE
by e-mail: international@cie.org.uk,
by phone: +44 1223 553554,
by fax: +44 1223 553558,
stating the Centre number, the nature of the query and the syllabus number quoted above.

This document consists of **10** printed pages and **2** blank pages.



Instructions for preparing apparatus

These instructions detail the apparatus required for each experiment in this paper. No access to the apparatus is permitted to the Question Paper in advance of the examination session.

Number of sets of apparatus

In addition to a few spare sets, the minimum number of sets of apparatus to be provided should be sufficient to enable candidates to spend 20 minutes with the apparatus for each of Questions 1, 2 and 3, and one hour with the apparatus for Question 4. The order in which candidates answer the questions will be determined by the Supervisor. Candidates may spend one hour circulating around Questions 1, 2 and 3, followed by an hour on Question 4, or vice versa.

It is assumed that candidates will supply their own calculator and geometrical instruments, such as a set square, 0° to 180° protractor, pair of compasses and 30 cm rule. Candidates should be advised in advance that they may, if they wish, use quartz wristwatches with stopwatch facilities, providing that such wristwatches afford the required precision.

Instructions for the supervision of the examination

The Supervisor, who may be a Physics teacher, is responsible for the administration of the examination according to the procedures detailed in the Handbook for Centres. In all instances, a Physics teacher should be present. Preferably, this teacher should have been responsible for the preparation of the apparatus. Two invigilators must be present at all times: it is not acceptable for a teacher who has been responsible for preparing the candidates for this paper to be the sole Supervisor or Invigilator.

Supervisors may make the following announcement at the start of the examination.

'The Examiners do not want you to waste time when you are unable to do any experiment. Any candidate who is unable to get results with an experiment may ask for help. The extent of this help will be reported to the Examiners, who may make a deduction of marks.'

Supervisors should note that a candidate may only be given enough assistance to allow some raw readings or observations to be made. On no account should any assistance be given with the treatment or analysis of these readings and observations.

Supervisors may draw to the attention of the candidates any significant deviation between the apparatus provided and that detailed in the Question Paper, particularly where diagrams are given in the paper.

Candidates should be reminded that all their work should be written on the Question Paper. Rough paper must not be used.

The Supervisor must complete the Report at the back of these Instructions. Details should be given of any significant deviation between the apparatus used and that specified in these Instructions. A sample set of results can often help Examiners. A copy of this Report must be included in **each** packet of scripts.

Question 1**Items to be supplied by the Centre (per set of apparatus, unless otherwise specified)**

80 g mass labelled M (see Note 1).

Thin string of approximate length 60 cm.

Split cork.

Stand, boss and clamp to support the cork (see Note 2).

Second length of thin string of approximate length 60 cm (see Note 3).

Pulley wheel, smooth running and supported about 20 cm above the bench (see Note 4).

50 g mass with hook (see Note 5).

Metre rule, with a millimetre scale.

Set square.

Notes

1. The value of the 80 g mass should be obscured from the candidates. It could be made by taping together a 50 g mass and three 10 g slotted masses. The complete mass should be labelled M.
2. One end of the thin string should be securely attached to the 80 g mass. The other end of the string should then be passed through the split cork as shown in Fig. 1.1.
3. One end of the second string should be tied firmly to the centre of the first string so that it does not slip. The knot should be 25.0 cm below the split cork. A loop should then be made at the free end of the second string. This is also shown in Fig. 1.1.

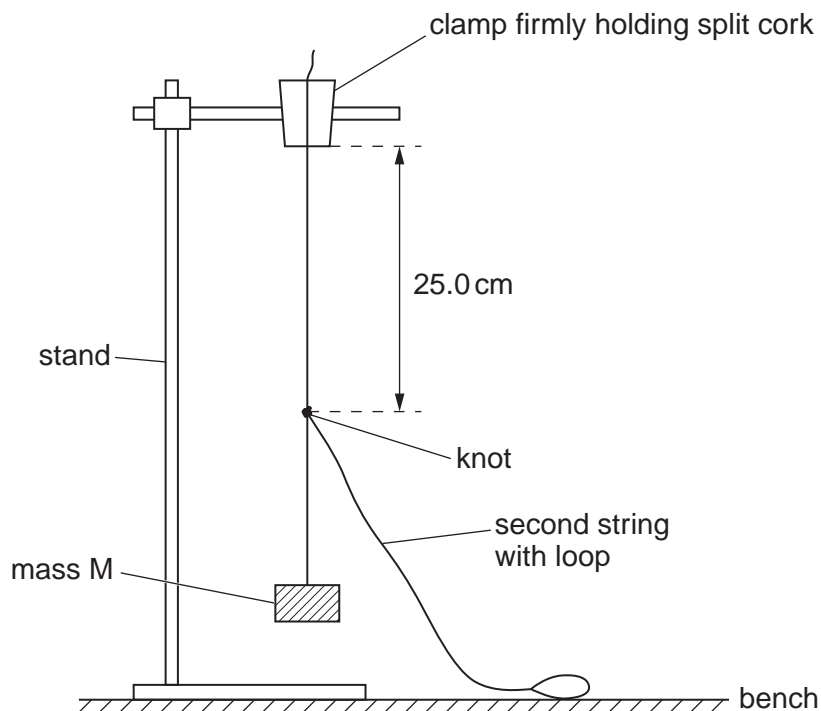

4. Candidates will need to adjust the position and height of the pulley wheel. If the pulley is of the type that is at the end of a bar, then a stand and boss would be suitable to support it.
5. The 50g mass, with hook, could be made from a 10g slotted mass hanger with four 10g slotted masses.
6. The **candidate** will set up the apparatus as shown in Fig. 1.2. The candidate will hook the 50g mass onto the loop on the string and adjust the position and height of the pulley so that the length of string BC is horizontal.

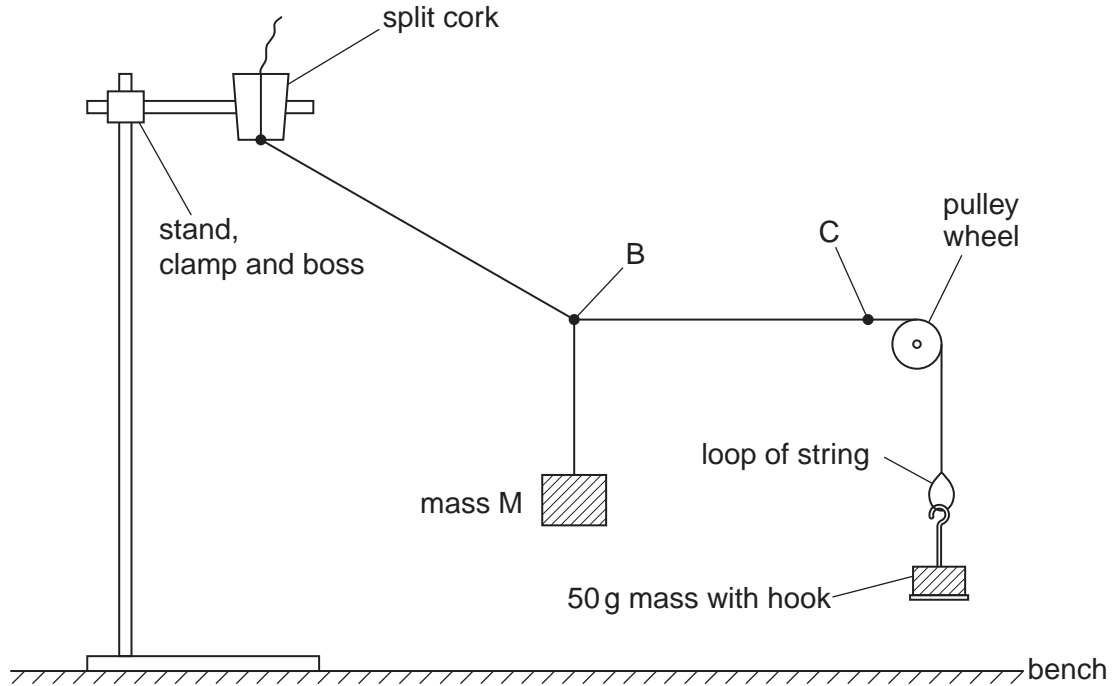

Fig. 1.2 (apparatus to be set up by the candidate)

7. At the changeover, the Supervisor should restore the apparatus to its original state as shown in Fig. 1.1.

Information required by Examiners

Sample set of numerical results, clearly marked "Supervisor's Results", obtained out of sight of the candidates.

Question 2**Items to be supplied by the Centre (per set of apparatus, unless otherwise specified)**

Expendable steel spring, with a spring constant of approximately 25 N/m, e.g. Griffin catalogue number XBV-590-010H (see Note 1).

100 g slotted mass hanger.

Four 100 g slotted masses (see Note 2).

Optics pin in cork to act as a fiducial mark.

Stand with two clamps and two bosses (see Note 3).

Stopwatch reading to 0.1 s or better.

Notes

1. If a suitable spring is not available, a rubber band may be used instead. The rubber band should be chosen such that a mass of 300 g has a period of oscillation of approximately 0.7 s, when suspended from the band.
2. The **candidate** will suspend masses of 300 g and 500 g from the spring. If slotted masses and a mass hanger are not available, then Supervisors may supply discrete masses of these values, provided they have a means of suspending them from the spring.
3. The **candidate** will suspend the spring from the top clamp and use the lower clamp to support the pin in cork horizontally.
4. At the changeover, the Supervisor should restore the apparatus to its original state.

Information required by Examiners

Time for 20 complete oscillations of the 300 g mass.

Sample set of numerical results, clearly marked "Supervisor's Results", obtained out of sight of the candidates.

Question 3**Items to be supplied by the Centre (per set of apparatus, unless otherwise specified)**

Converging lens of focal length 15 cm.

Lens holder.

White screen of approximate dimensions 20 cm × 20 cm (see Note 1).

Piece of stripboard (as used in building some electronic circuits), with dimensions approximately 4 cm × 4 cm (see Note 2).

Means of supporting the stripboard in an upright position.

Lamp to illuminate the stripboard (see Note 3).

Sheet of graph paper, with a 1 mm or 2 mm grid, approximately 10 cm × 10 cm (see Note 4).

Metre rule, with a millimetre scale.

Set square.

Notes

1. The screen should be supported so that it stands perpendicular to the bench. This may be done by attaching a block of wood to the back of the screen.
2. The stripboard must have a grid of regularly-spaced holes that are 2.5 mm apart in both the vertical and horizontal directions. The holes should be approximately 1 mm in diameter.

If stripboard is not available, a line of 10 holes should be drilled in a piece of stiff card. The holes should be 2.5 mm apart and approximately 1 mm in diameter. The Supervisor should check that a clear magnified image of the holes can be formed on the screen, when the board is illuminated.

3. The centre of the stripboard, the lamp and the centre of the lens, when it is supported in the holder, should be at the same height above the bench.
4. The sheet of graph paper should be secured to the central part of the screen.
5. The apparatus should be in a dimly lit area of the laboratory and the lamp should be of sufficient brightness to enable candidates to see images formed on the screen.
6. At the changeover, the Supervisor should dismantle any apparatus that has been left set up by the candidate. A new sheet of graph paper should be attached to the screen, if necessary.

Information required by Examiners

Sample set of numerical results, clearly marked “Supervisor’s Results”, obtained out of sight of the candidates.

Question 4**Items to be supplied by the Centre (per set of apparatus, unless otherwise specified)**

4.5V or 5.0V d.c. power supply, e.g. three 1.5V dry cells in a suitable holder.

A resistor of nominal value 33Ω , labelled X, e.g. RS Components product code 131-744 (see Note 1).

Ammeter capable of measuring a current of up to 200 mA to 1 mA or better. An analogue or digital meter is suitable.

Voltmeter capable of measuring a potential difference of up to 5V to 0.05V or better. An analogue or digital meter is suitable.

Switch or plug key.

Three resistors of nominal values 10Ω (e.g. RS 131-716), 15Ω (e.g. RS 131-722) and 22Ω (e.g. RS 131-738) (see Note 2).

Seven connecting leads (see Note 3).

Four further connecting leads (see Note 4).

Notes

1. The value of resistor X should be obscured from the candidates.
2. All four resistors should have suitable terminals to enable them to be connected to each other and to the remainder of the circuit. The RS numbers quoted are for resistors rated at 1W. If an alternative supplier is used, the resistors must have a power rating of at least 1W. The 10Ω , 15Ω and 22Ω resistors should be labelled with their nominal values.
3. The Supervisor should set up the apparatus as shown in Fig. 4.1. The terminals A and B should be clearly labelled.

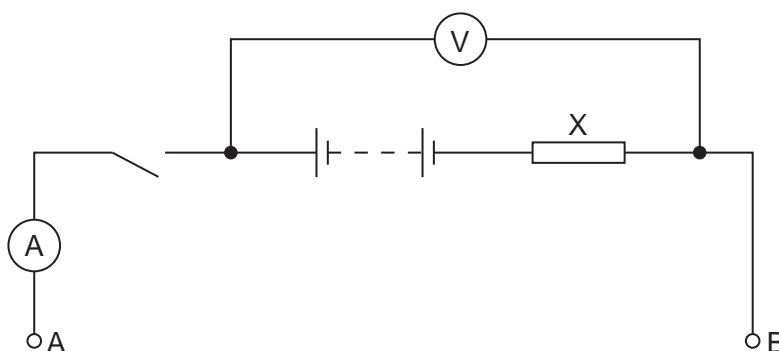

Fig. 4.1

4. The four further connecting leads may be required by the candidate to connect the three resistors in series between points A and B.
5. At the changeover, the apparatus should be restored to its original state as in Fig. 4.1, removing the resistors between A and B. If cells are used, they should be checked and replaced, if necessary.

Information required by Examiners

Sample set of numerical results, clearly marked "Supervisor's Results", obtained out of sight of the candidates.

This form must be completed and returned with the candidates' scripts.

REPORT ON PRACTICAL PHYSICS

The Supervisor is asked to give the following details, using the space provided on page 12.

- (a) Information required at the end of the test, as indicated in the Instructions.
- (b) Any help given to a candidate.
- (c) Any general difficulties encountered in preparing the apparatus.
- (d) Any difficulties experienced by particular candidates. These should include reference to difficulties due to faulty apparatus or materials and accidental damage to apparatus or materials. Candidates should be identified by name and candidate number.

Other cases of hardship, such as disability or illness, should be reported to CIE in the normal way.

The Supervisor is asked to provide a plan of the work benches, giving details by candidate numbers of the places occupied by the candidates for each session. The plan and report should be enclosed in the envelope containing the candidates' scripts. If more than one envelope is used, a copy of the report must be enclosed in each envelope.

Declaration to be signed by the Principal

The preparation of this practical examination has been carried out so as to maintain fully the security of the examination.

Signed

Name (in block capitals)

Centre number

Centre name



Information required

1. Time, t , for 20 complete oscillations of the 300 g mass used in Question 2.

$t = \dots\dots\dots$

2. For questions 1, 2, 3 and 4, please enclose a sample set of numerical results, obtained out of sight of the candidates and clearly labelled "Supervisor's Results".

Details of difficulties and any help given to candidates