



UNIVERSITY OF CAMBRIDGE INTERNATIONAL EXAMINATIONS
General Certificate of Education Ordinary Level

CANDIDATE
NAME

CENTRE
NUMBER

--	--	--	--	--

CANDIDATE
NUMBER

--	--	--	--



PHYSICS

5054/21

Paper 2 Theory

October/November 2012

1 hour 45 minutes

Candidates answer on the Question Paper.

No Additional Materials are required.

READ THESE INSTRUCTIONS FIRST

Write your Centre number, candidate number and name on all the work you hand in.

Write in dark blue or black pen.

You may use a soft pencil for any diagrams, graphs or rough working.

Do not use staples, paper clips, highlighters, glue or correction fluid.

DO NOT WRITE IN ANY BARCODES.

Section A

Answer **all** questions.

Write your answers in the spaces provided on the Question Paper.

Section B

Answer any **two** questions.

Write your answers in the spaces provided on the Question Paper.

You may lose marks if you do not show your working or if you do not use appropriate units.

At the end of the examination, fasten all your work securely together.

The number of marks is given in brackets [] at the end of each question or part question.

For Examiner's Use	
Section A	
Q9	
Q10	
Q11	
Total	

This document consists of **16** printed pages.



Section A

Answer **all** the questions in this section. Answer in the spaces provided.



- 1 A parachutist of total weight 950 N falls vertically at a constant velocity of 6.5 m/s.
- (a) State the size and direction of the resistive (drag) force acting on the parachutist.

size of resistive force:

direction of resistive force:

[2]

- (b) At a certain height, the wind starts to blow and the parachutist moves horizontally at a velocity of 4.5 m/s as he continues to fall.

Use a graphical method to add together the horizontal and the vertical velocities to determine the size of the resultant velocity of the parachutist. Label the velocities and state the scale that you use.

size of velocity =

scale =

- 2 A thermocouple thermometer is made from two different metals and a voltmeter. One junction of the thermocouple thermometer is placed in a beaker containing a mixture of water and ice. The other junction is placed inside a high-temperature furnace, as shown in Fig. 2.1.

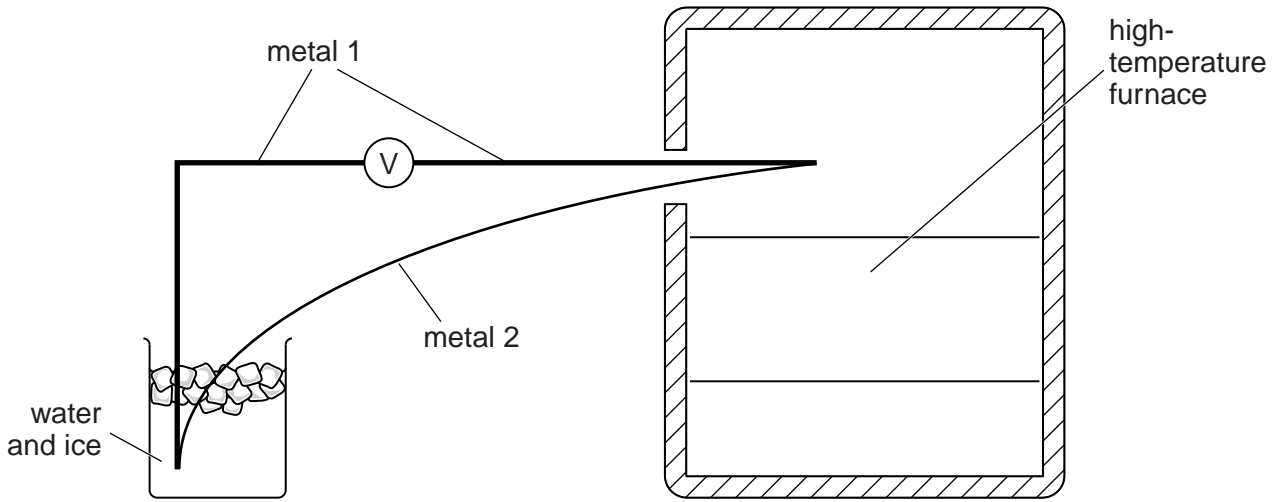

Fig. 2.1

- (a) The thermocouple thermometer has a linear output over the operating temperature range of the furnace.

- (i) State what, for a thermocouple thermometer, is meant by a *linear output*.

.....
 [1]

- (ii) The junction inside the furnace is at temperature T . Fig. 2.2 shows the reading V of the voltmeter at two values of T that are within the operating temperature range of the furnace.

$T/^\circ\text{C}$	V/mV
750	6.20
800	7.70

Fig. 2.2

When the furnace is operating at a high temperature, the furnace door is opened and the reading of the voltmeter falls to 6.80 mV.

Calculate the temperature of the junction inside the furnace.

temperature = [2]

- (b) State why a liquid-in-glass thermometer is not used to measure the temperature inside the furnace.

.....

3 Fig. 3.1 shows an electric motor being used on a building site to lift bricks.

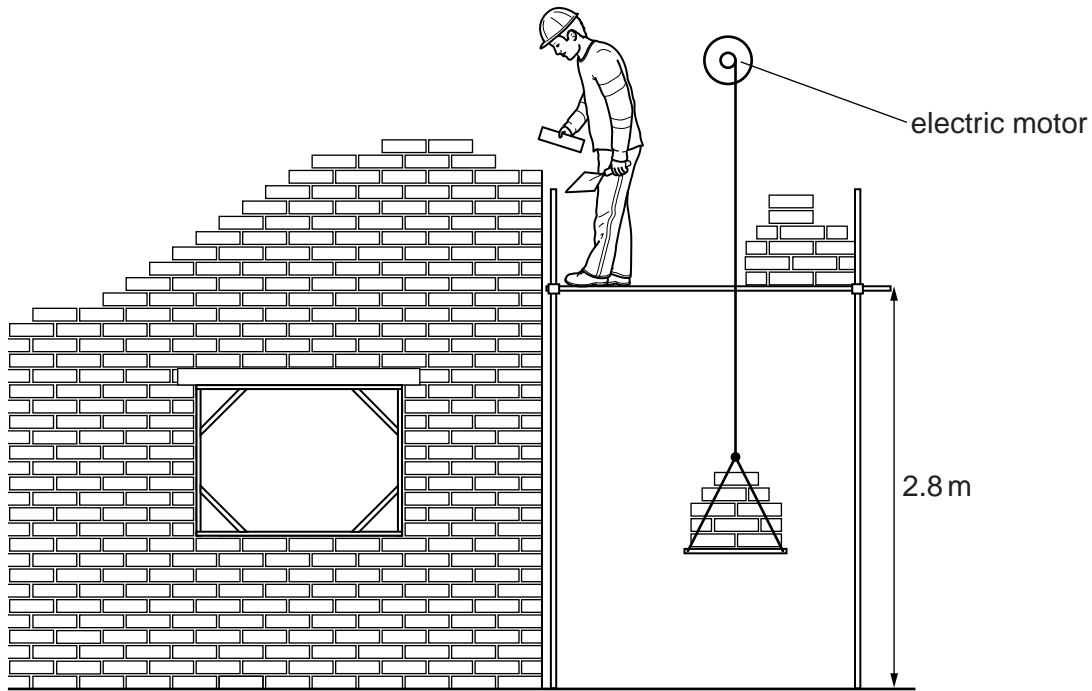

Fig. 3.1

The gravitational field strength is 10 N/kg. The motor lifts bricks of total mass 54 kg through a height of 2.8 m in 3.0 s.

(a) Calculate

(i) the work done in lifting the bricks,

work done = [2]

(ii) the useful output power of the motor.

power = [2]

(b) Suggest two reasons why the electrical power supplied to the motor is greater than its useful output power.

1.

2.

- (c) (i) Fig. 3.2 shows a battery and an electric motor. The battery is used to power the motor. Complete Fig. 3.2 to show the circuit diagram of a circuit that is used to determine the power supplied to the electric motor.

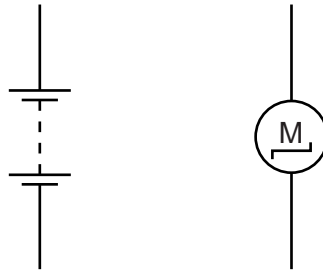

Fig. 3.2

[2]

- (ii) State how the power supplied is calculated.

.....

..... [1]

- 4 A petrol tanker has mass 2800 kg when empty and holds 30 m^3 of petrol when full. The density of petrol is 740 kg/m^3 .

(a) Calculate the total mass of the tanker when full of petrol.

mass = [2]

- (b) The full tanker is travelling along a road when the driver observes an obstruction and applies the brakes. A resultant force of 30 000 N acts on the tanker.

Calculate the deceleration of the tanker.

deceleration = [2]

- 5 A water wave of frequency 3.6 Hz is generated in a ripple tank. Fig. 5.1 is a scale drawing that shows the wavefronts travelling from deep water to shallow water in the ripple tank. A length of 1.0 cm on the diagram represents 8.0 cm in the ripple tank.

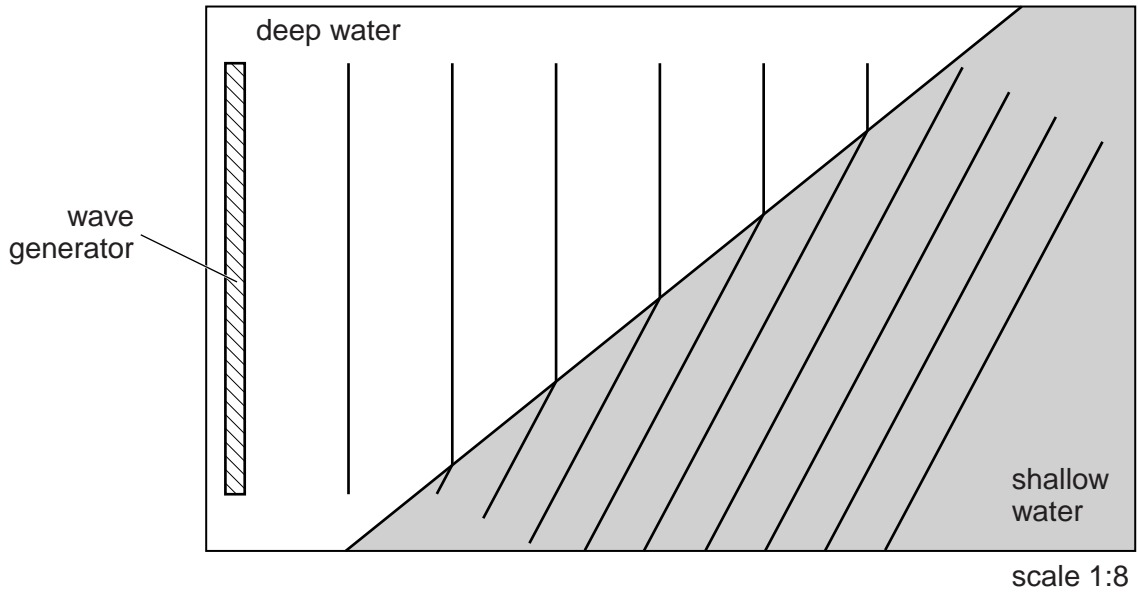

Fig. 5.1

- (a) (i) Using measurements from Fig. 5.1, determine the wavelength of the wave in the deep water.

wavelength = [2]

- (ii) Calculate the speed of the wave in the deep water.

speed = [2]

- (b) As the wave passes into the shallow water, state what happens to

- (i) the frequency,

..... [1]

- (ii) the speed.

..... [1]

- 6 (a) Fig. 6.1 shows part of a page from a pupil's notebook.

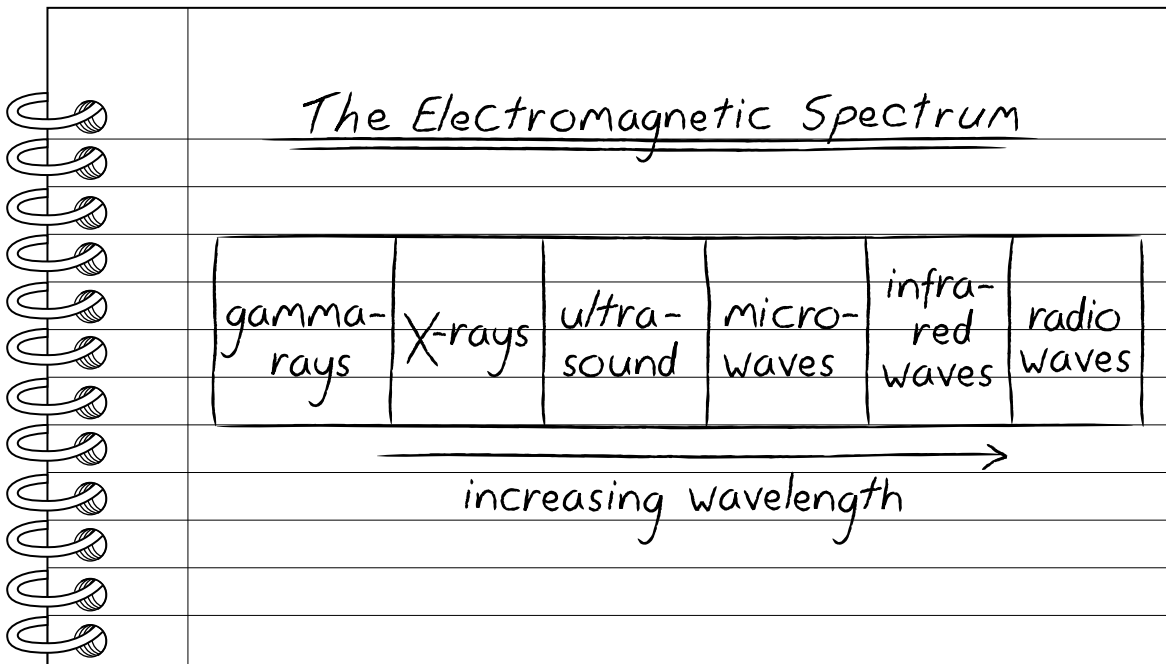

Fig. 6.1

List three errors in the pupil's notes.

1.
2.
3.

[3]

- (b) State and explain one application of X-rays in engineering.

.....

.....

..... [2]

- 7 (a) Fig. 7.1 shows a solenoid made from wire wound around a plastic cylinder.

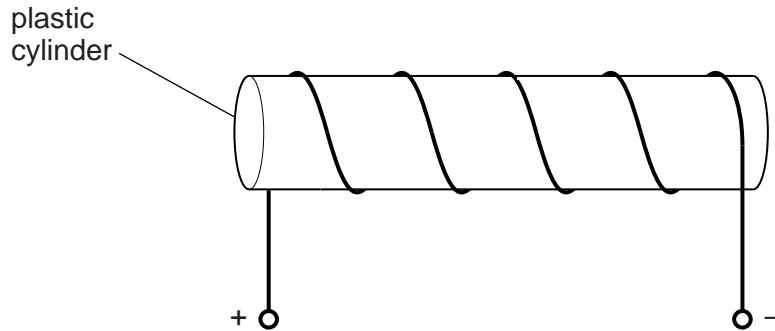

Fig. 7.1

A current in the solenoid produces a magnetic field.

On Fig. 7.1, draw the pattern of the magnetic field lines inside and outside the cylinder. [2]

- (b) Fig. 7.2 shows a beam of beta-particles, in a vacuum, passing into a magnetic field.

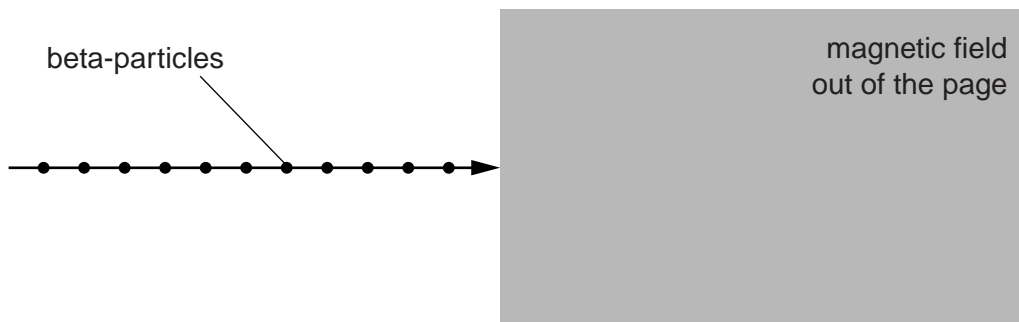

Fig. 7.2

The movement of the beta-particles from left to right is an electric current.

- (i) On Fig. 7.2, draw an arrow to show the direction of the conventional current. [1]
- (ii) A solenoid is used to produce the magnetic field that lies within the shaded region of Fig. 7.2. The direction of the field is out of the page.
- On Fig. 7.2, draw the path followed by one of the beta-particles in the shaded region. [2]
 - The direction of the current in the solenoid is reversed. State what happens to the path of the beta-particle.

.....

.....

- 8 A $600\ \Omega$ resistor and a thermistor are connected in series with an ammeter and a 20 V (direct current) power supply. A voltmeter is in parallel with the resistor.

Fig. 8.1 is the circuit diagram.

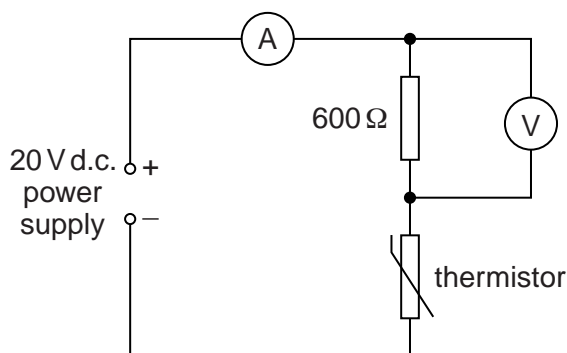

Fig. 8.1

The ammeter reads 0.025 A.

- (a) Calculate

- (i) the reading on the voltmeter,

reading = [2]

- (ii) the resistance of the thermistor.

resistance = [2]

- (b) The temperature of the thermistor increases.

State what, if anything, happens to

- (i) the resistance of the thermistor,

..... [1]

- (ii) the ammeter reading and to the voltmeter reading.

ammeter reading:

voltmeter reading:

[1]

Section B

Answer **two** questions from this section. Answer in the spaces provided.

- 9 A submarine is at rest deep beneath the surface of the sea. The gravitational field strength is 10 N/kg , the atmospheric pressure is $1.0 \times 10^5\text{ Pa}$ and the density of sea water is $1.0 \times 10^3\text{ kg/m}^3$.

(a) Calculate

- (i) the pressure due to the sea water at a depth of 120 m ,

pressure = [2]

- (ii) the total pressure at a depth of 120 m .

total pressure = [1]

- (b) Fig. 9.1 shows a horizontal hatch of surface area 0.45 m^2 on the top of the submarine. The hatch is at a depth of 120 m beneath the surface of the sea.

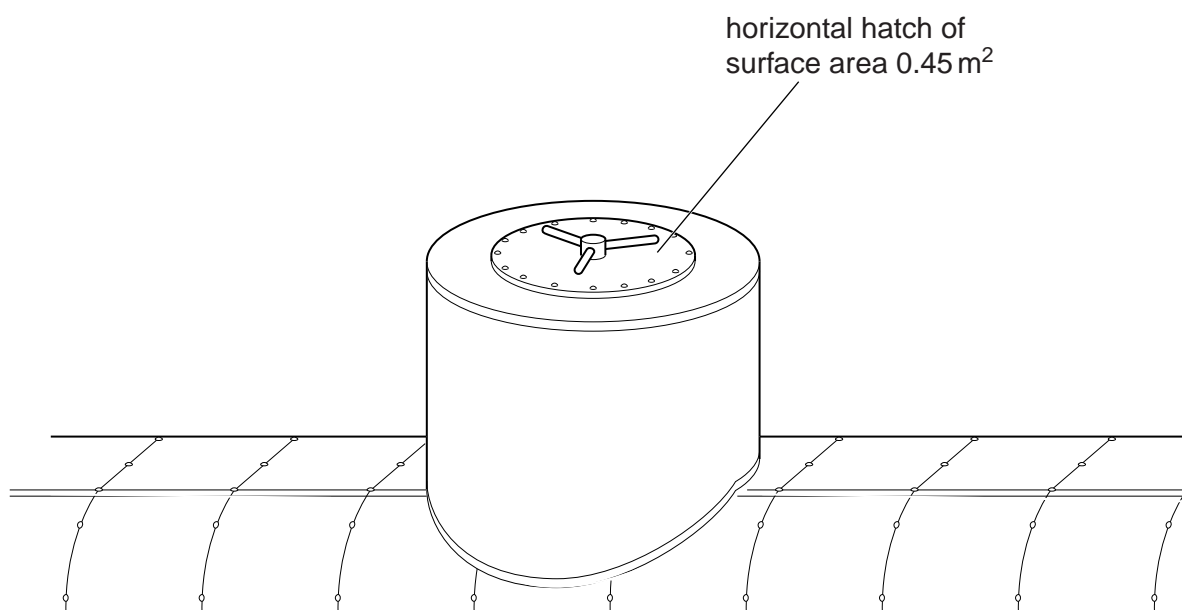
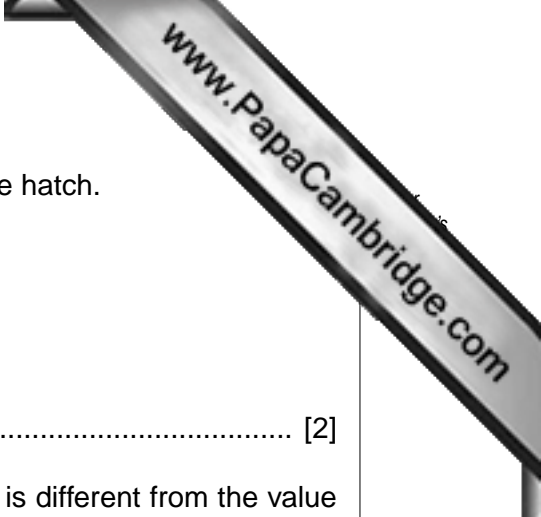

Fig. 9.1



(i) Calculate the downward force acting on the surface of the hatch.

force = [2]

(ii) State two reasons why the force needed to lift the hatch is different from the value calculated in (i).

1.

2.

[2]

(c) The submarine uses ultrasound to detect obstacles.

(i) State what is meant by *ultrasound*.

.....

..... [2]

(ii) The ultrasound is produced by a vibrating source.

Describe how the ultrasound is transmitted through the water.

.....

.....

.....

..... [3]

(iii) An ultrasound pulse is emitted. At a later time, the reflected pulse is detected. The time between the emission and the detection of the pulse is t .

1. State the other quantity that must be known in order to determine the distance of the obstacle from the submarine.

..... [1]

2. State how the distance of the obstacle from the submarine is calculated.

..... [1]

(iv) State one other use of ultrasound.

.....

..... [1]

- 10 Fig. 10.1 shows a domestic heater that is used to heat a room. It contains 16 large bricks each of mass 7.5 kg.

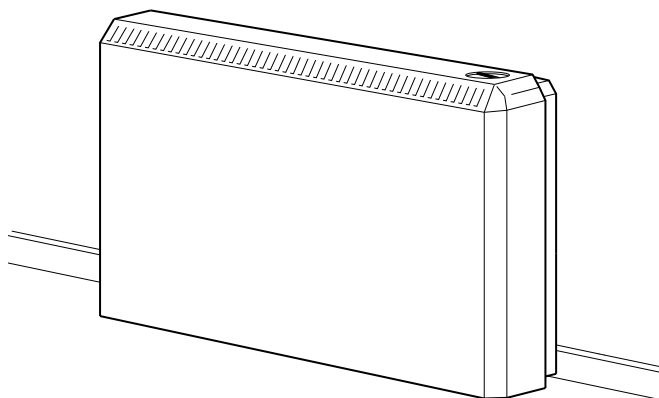

Fig. 10.1

During the night, the bricks are heated from a temperature of 17 °C to 96 °C. The bricks are made from a material that has a specific heat capacity of 2300 J/(kg °C).

- (a) Calculate the thermal energy (heat) supplied to the bricks.

thermal energy = [3]

- (b) During the day, the bricks gradually cool and the stored thermal energy is released to the room. After 7.0 hours, the bricks have cooled to 17 °C.

- (i) Calculate the average rate of release of thermal energy to the room during these 7.0 hours.

rate = [2]

- (ii) At the beginning of the day, the heater releases thermal energy at a greater rate than later in the day.

Suggest why.

.....

 [2]

- (c) Fig. 10.2 is a diagram of the heater standing on the floor of the room and placed against one of the walls.

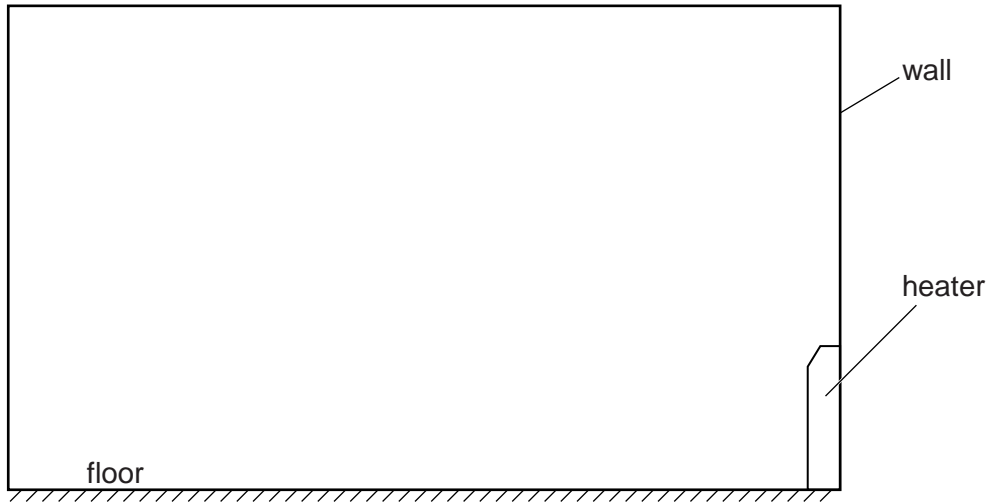

Fig. 10.2

Describe, and explain in detail, how the thermal energy is transferred throughout the room. You may draw on Fig. 10.2.

.....

.....

.....

.....

.....

.....

..... [5]

- (d) State one method of thermal insulation that is used to keep a room warm, and explain why it is effective.

.....

.....

.....

.....

..... [3]

- 11 (a) Fig. 11.1 shows a thunder cloud with a flat, positively charged base. It passes over a tree growing in a region of flat, open land.

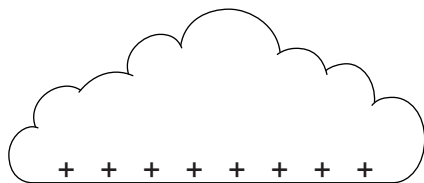

Fig. 11.1 (not to scale)

- (i) On Fig. 11.1, mark the charge on the tree. [1]
 (ii) Explain how the tree becomes charged.

.....

 [2]

- (iii) A lightning strike occurs and, in 2.0×10^{-4} s, a charge of 560 C passes from the cloud to the tree. The size of the charge on an electron is 1.6×10^{-19} C.

1. Calculate the number of electrons that pass between the tree and the cloud.

number = [2]

2. Calculate the average current in the lightning strike.

current = [2]

- (b) Two flat metal plates are positioned horizontally, one above the other. Fig. 11.2 shows the positive terminal of a high-voltage supply unit connected to the bottom plate and the negative terminal connected to the top plate.

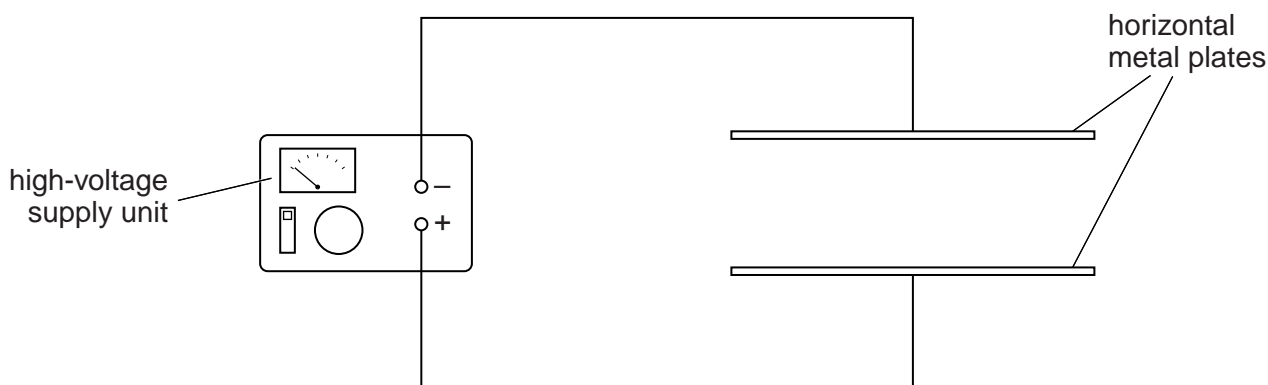

Fig. 11.2

The high-voltage supply is switched on.

- (i) On Fig. 11.2, draw the shape and the direction of the electric field produced. [3]
 (ii) Suggest why a small, charged oil droplet placed between the two metal plates accelerates upwards.

.....

 [3]

- (iii) The oil droplet touches the top metal plate. State and explain what happens to the charge on the oil droplet.

.....

 [2]

Permission to reproduce items where third-party owned material protected by copyright is included has been sought and cleared where possible. Every reasonable effort has been made by the publisher (UCLES) to trace copyright holders, but if any items requiring clearance have unwittingly been included, the publisher will be pleased to make amends at the earliest possible opportunity.