

CANDIDATE
NAME

CENTRE
NUMBER

--	--	--	--	--

CANDIDATE
NUMBER

--	--	--	--



PHYSICS (PRINCIPAL)

Paper 3 Written Paper

9792/03

May/June 2019

3 hours

Candidates answer on the Question Paper.

No Additional Materials are required.

READ THESE INSTRUCTIONS FIRST

Write your centre number, candidate number and name on all the work you hand in.

Write in dark blue or black pen.

You may use an HB pencil for any diagrams or graphs.

Do not use staples, paper clips, glue or correction fluid.

DO NOT WRITE IN ANY BARCODES.

Section 1

Answer **all** questions.

You are advised to spend about 1 hour 30 minutes on this section.

Section 2

Answer any **three** questions. All six questions carry equal marks.

You are advised to spend about 1 hour 30 minutes on this section.

Electronic calculators may be used.

You may lose marks if you do not show your working or if you do not use appropriate units.

At the end of the examination, fasten all your work securely together.

The number of marks is given in brackets [] at the end of each question or part question.

For Examiner's Use

1	
2	
3	
4	
5	
6	
7	
8	
9	
10	
11	
12	
13	
Total	

This syllabus is regulated for use in England, Wales and Northern Ireland as a Cambridge International Level 3 Pre-U Certificate.

This document consists of **41** printed pages and **3** blank pages.

Data

gravitational field strength close to Earth's surface	$g = 9.81 \text{ N kg}^{-1}$
elementary charge	$e = 1.60 \times 10^{-19} \text{ C}$
speed of light in vacuum	$c = 3.00 \times 10^8 \text{ m s}^{-1}$
Planck constant	$h = 6.63 \times 10^{-34} \text{ J s}$
permittivity of free space	$\epsilon_0 = 8.85 \times 10^{-12} \text{ F m}^{-1}$
gravitational constant	$G = 6.67 \times 10^{-11} \text{ N m}^2 \text{ kg}^{-2}$
electron mass	$m_e = 9.11 \times 10^{-31} \text{ kg}$
proton mass	$m_p = 1.67 \times 10^{-27} \text{ kg}$
unified atomic mass constant	$u = 1.66 \times 10^{-27} \text{ kg}$
molar gas constant	$R = 8.31 \text{ J K}^{-1} \text{ mol}^{-1}$
Avogadro constant	$N_A = 6.02 \times 10^{23} \text{ mol}^{-1}$
Boltzmann constant	$k = 1.38 \times 10^{-23} \text{ J K}^{-1}$
Stefan-Boltzmann constant	$\sigma = 5.67 \times 10^{-8} \text{ W m}^{-2} \text{ K}^{-4}$

Formulae

uniformly accelerated motion	$s = ut + \frac{1}{2}at^2$	change of state	$\Delta E = mL$	
	$v^2 = u^2 + 2as$		refraction	$n = \frac{\sin\theta_1}{\sin\theta_2}$
	$s = \left(\frac{u+v}{2}\right)t$			$n = \frac{v_1}{v_2}$
heating	$\Delta E = mc\Delta\theta$			

diffraction		electromagnetic induction	$E = -\frac{d(N\Phi)}{dt}$
single slit, minima	$n\lambda = b \sin\theta$	Hall effect	$V = Bvd$
grating, maxima	$n\lambda = d \sin\theta$	time dilation	$t' = \frac{t}{\sqrt{1 - \frac{v^2}{c^2}}}$
double slit interference	$\lambda = \frac{ax}{D}$	length contraction	$l' = l\sqrt{1 - \frac{v^2}{c^2}}$
Rayleigh criterion	$\theta \approx \frac{\lambda}{b}$	kinetic theory	$\frac{1}{2}m\langle c^2 \rangle = \frac{3}{2}kT$
photon energy	$E = hf$	work done on/by a gas	$W = p\Delta V$
de Broglie wavelength	$\lambda = \frac{h}{p}$	radioactive decay	$\frac{dN}{dt} = -\lambda N$ $N = N_0 e^{-\lambda t}$ $t_{\frac{1}{2}} = \frac{\ln 2}{\lambda}$
simple harmonic motion	$x = A \cos \omega t$ $v = -A\omega \sin \omega t$ $a = -A\omega^2 \cos \omega t$ $F = -m\omega^2 x$ $E = \frac{1}{2}mA^2\omega^2$	attenuation losses	$I = I_0 e^{-\mu x}$
energy stored in a capacitor	$W = \frac{1}{2}QV$	mass-energy equivalence	$\Delta E = c^2\Delta m$
capacitor discharge	$Q = Q_0 e^{-\frac{t}{RC}}$	hydrogen energy levels	$E_n = \frac{-13.6\text{eV}}{n^2}$
electric force	$F = \frac{Q_1 Q_2}{4\pi\epsilon_0 r^2}$	Heisenberg uncertainty principle	$\Delta p \Delta x \geq \frac{h}{2\pi}$
electrostatic potential energy	$W = \frac{Q_1 Q_2}{4\pi\epsilon_0 r}$	Wien's displacement law	$\lambda_{\max} \propto \frac{1}{T}$
gravitational force	$F = -\frac{Gm_1 m_2}{r^2}$	Stefan's law	$L = 4\pi\sigma r^2 T^4$
gravitational potential energy	$E = -\frac{Gm_1 m_2}{r}$	electromagnetic radiation from a moving source	$\frac{\Delta\lambda}{\lambda} \approx \frac{\Delta f}{f} \approx \frac{v}{c}$
magnetic force	$F = BIl \sin\theta$ $F = BQv \sin\theta$		

Section 1

Answer **all** questions in this section.

You are advised to spend about 1 hour 30 minutes on this section.

- 1 (a) State what is meant by *centripetal* acceleration.

.....
 [1]

- (b) A train is designed so that its carriages tilt slightly inwards, at an angle θ , as the train travels around corners. This is to ensure that the contact force from the seat continues to act through the centre of gravity of a passenger so that the passenger has a more comfortable ride.

Fig. 1.1 shows a cross-section through the carriage of a train travelling around a corner. Fig. 1.2 shows the forces acting on a passenger of mass m in this carriage.

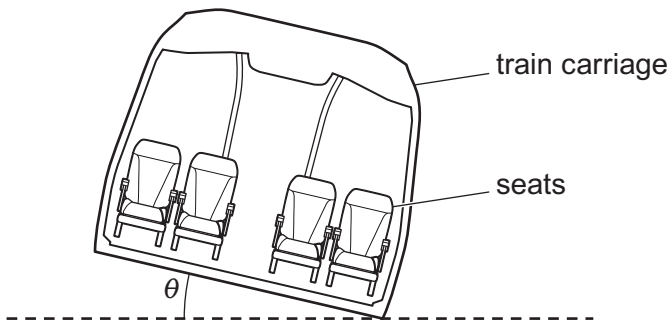

Fig. 1.1
(cross-section through carriage)

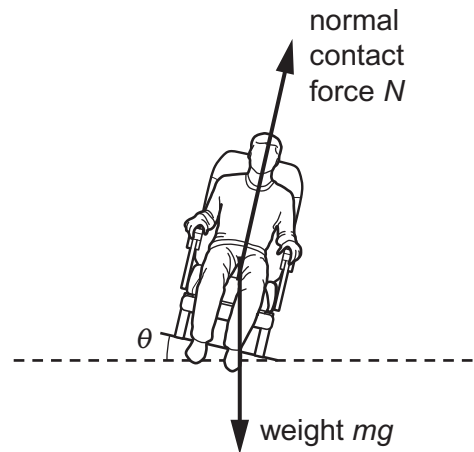

Fig. 1.2
(forces on passenger)

- (i) Explain, with reference to Fig. 1.2, why the passenger will have a more comfortable ride when the contact force acts through the centre of gravity of the passenger when travelling around a corner.

.....

 [2]

- (ii) Show that, for the train travelling at speed v around a corner of radius r , the angle of tilt θ is given by:

$$\tan \theta = \frac{v^2}{rg}$$

[3]

- (c) The train moving at a constant speed of 60 ms^{-1} travels along a horizontal section of track between points X and Y, as shown in the view from above in Fig. 1.3.

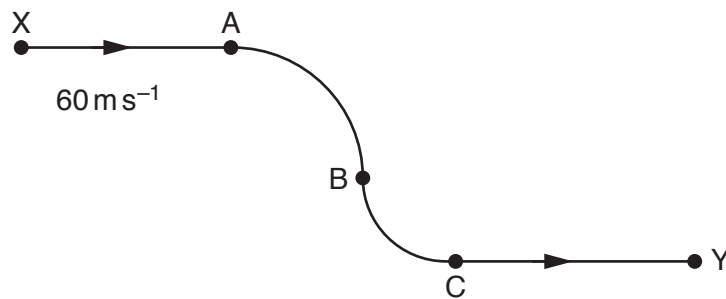

Fig. 1.3 (view from above)

The radius of the curve between points A and B is 4.2 km. The radius of the curve between points B and C is 2.1 km.

Sketch a graph on Fig. 1.4 to show the variation of the angle of tilt θ with the distance along the track between X and Y. Label the vertical axis with suitable values.

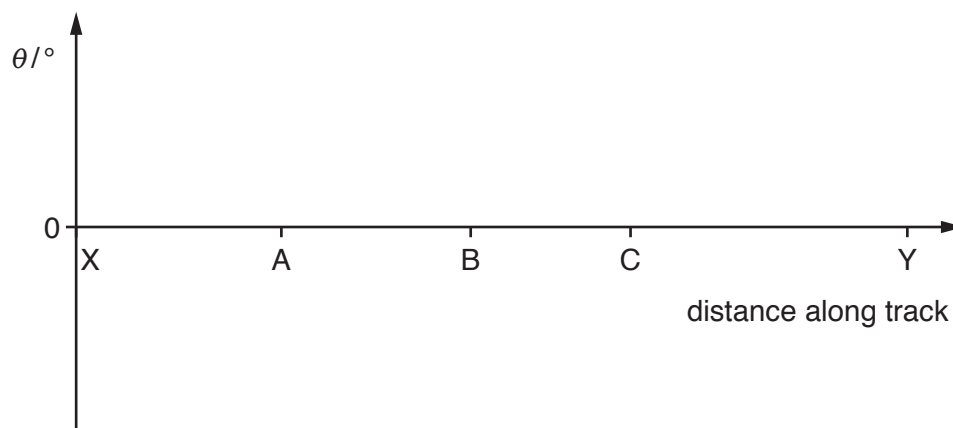

Fig. 1.4

[4]

(d) Suggest, with a reason, the extent to which it is possible to ensure an equally comfortable ride for all of the passengers in the train.

.....

.....

..... [1]

[Total: 11]

2 (a) Define *capacitance*.

.....
 [1]

(b) A capacitor of capacitance $40\ \mu\text{F}$ is connected into the circuit shown in Fig. 2.1.

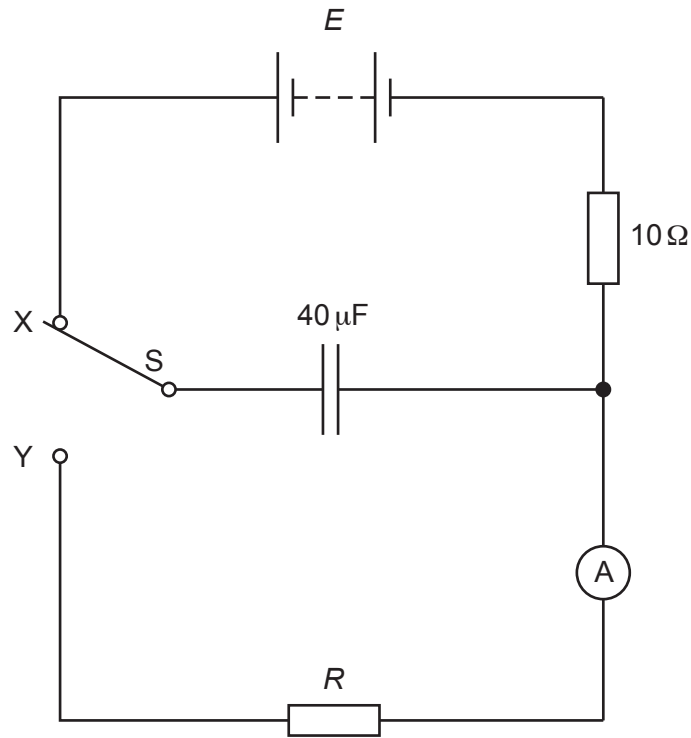

Fig. 2.1

The two-way switch S is initially connected to terminal X so that the capacitor charges through the $10\ \Omega$ resistor.

(i) The time constant of the charging circuit is the same as the time constant for the capacitor discharging through a $10\ \Omega$ resistor.

Calculate the time constant of the charging circuit.

time constant = s [1]

(ii) The capacitor can be considered to be fully charged after charging for 0.10 s.

Suggest a reason to explain this, with reference to your answer in (b)(i).

.....
 [1]

- (c) The switch S in Fig. 2.1 is now connected to terminal Y, at time $t = 0$. The current I indicated by the ammeter is recorded at times t as shown in the table of Fig. 2.2.

t/s	I/mA	$\ln(I/\text{mA})$
0.10	0.53	
0.20	0.47	
0.30	0.41	
0.40	0.36	
0.50	0.32	
0.60	0.28	

Fig. 2.2

- (i) Complete the table in Fig. 2.2 by calculating values of $\ln(I/\text{mA})$. [2]
- (ii) Plot a graph, on the axes of Fig. 2.3, of $\ln(I/\text{mA})$ against t .
Draw a line of best fit on your graph. [2]

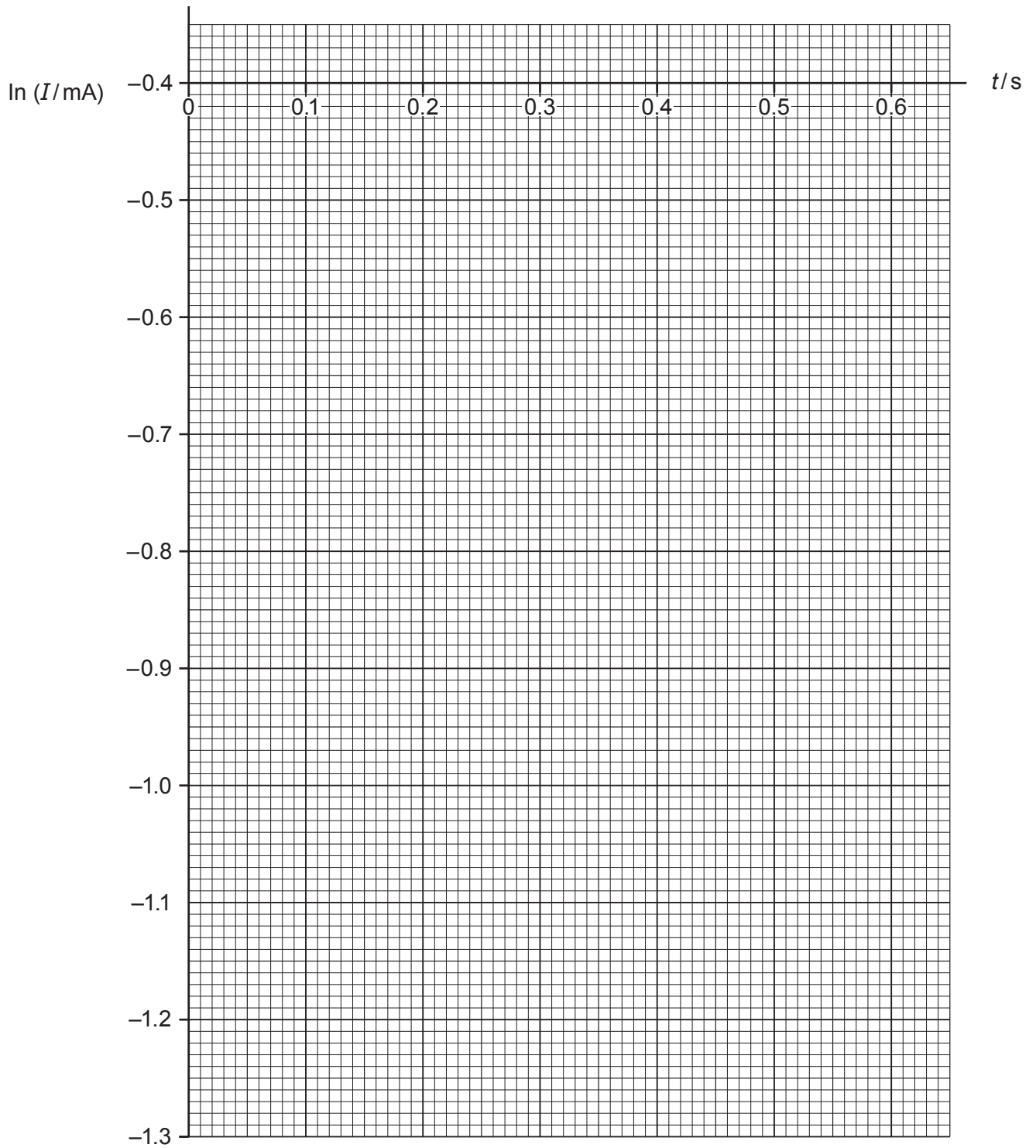

Fig. 2.3

(d) Use your graph in Fig. 2.3 to determine:

(i) the current in the discharge circuit in Fig. 2.1 at time $t = 0$

current =mA [2]

(ii) the time constant of the discharge circuit

time constant = s [2]

(iii) the resistance R of the resistor in the discharge circuit

$R = \dots\dots\dots \text{k}\Omega$ [1]

(iv) the electromotive force (e.m.f.) E of the battery.

$E = \dots\dots\dots \text{V}$ [1]

[Total: 13]

- 3 (a) State what is meant by the *gravitational potential energy* stored between two point masses that are separated by some distance from each other.

.....

 [2]

- (b) A spherical planet has a mean density ρ and radius R .

Give expressions, in terms of ρ and R , for:

- (i) the mass of the planet

[1]

- (ii) the gravitational potential energy of an object of mass m at the surface of the planet.

[1]

- (c) (i) Use your answer in (b)(ii) to show that the escape velocity v for the planet is given by:

$$v = \sqrt{\frac{8\pi GR^2\rho}{3}}$$

[3]

- (ii) The Moon has a radius of $1.74 \times 10^6 \text{ m}$ and a mean density of $3.34 \times 10^3 \text{ kg m}^{-3}$.

Calculate the escape velocity for an object on the surface of the Moon.

escape velocity = ms^{-1} [1]

- (d) (i) The temperature of the surface of the Moon exceeds 100°C during its day.

Calculate the root mean square (r.m.s.) speed of a molecule of hydrogen gas, ${}^1_1\text{H}_2$, at 100°C .

r.m.s. speed = ms^{-1} [3]

- (ii) Suggest why the Moon cannot have a hydrogen atmosphere.

.....

 [1]

[Total: 12]

- 4 (a) (i) State *Faraday's law* of electromagnetic induction.

.....
 [2]

- (ii) State *Lenz's law* of electromagnetic induction.

.....
 [1]

- (b) A helicopter has four main rotor blades, each of length 8.0 m, as shown in Fig. 4.1 and Fig. 4.2.

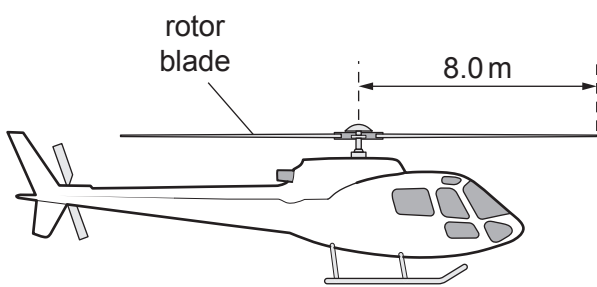

Fig. 4.1
(view from the side)

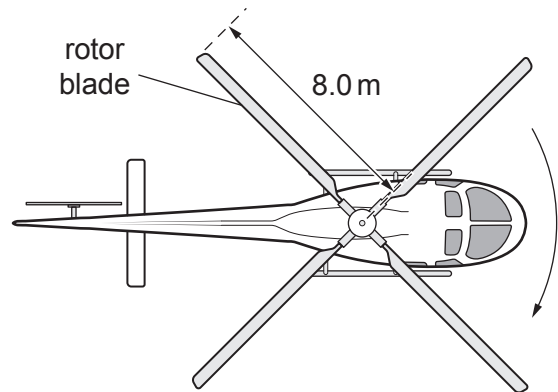

Fig. 4.2
(view from above)

The rotor blades are horizontal and rotating at 200 revolutions per second. This causes the helicopter to remain stationary in equilibrium in the air. Viewed from above, the direction of rotation is clockwise.

The Earth's magnetic field through the rotor blades is uniform. It has a magnitude of $4.7 \times 10^{-5} \text{ T}$ and is in a direction downwards at an angle of 50° to the horizontal, as shown in Fig. 4.3.

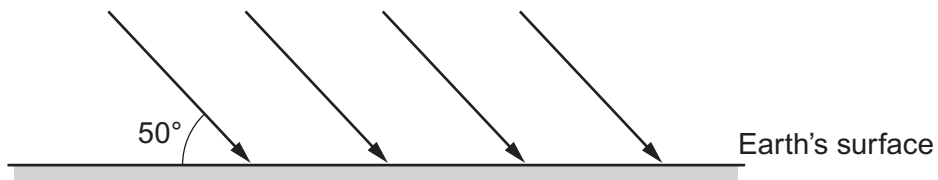

Fig. 4.3

- (i) Calculate the magnetic flux cut by one rotor blade during one complete revolution. Give a unit with your answer.

magnetic flux = unit [3]

- (ii) Calculate the e.m.f. induced across the two ends of this rotor blade.

e.m.f. =V [2]

- (iii) State, with a reason, which end of the rotor blade (the inner end or the outer end) is at the higher potential.

.....
.....
.....
..... [2]

- (iv) State, with a reason, the potential difference between the outer ends of two rotor blades that are directly opposite to each other.

.....
.....
..... [2]

[Total: 12]

5 (a) State two assumptions that are made in the kinetic theory model of gases about the particles in an ideal gas.

1.
 2.
- [2]

(b) (i) Describe what is observed in Brownian motion.

.....
 [1]

(ii) Explain how these observations provide evidence for the kinetic theory.

.....
 [1]

(c) A sample of an ideal gas containing 5.00 mol of the gas is at a temperature of 300 K and exerts a pressure of 1.00×10^5 Pa.

(i) Calculate the volume of the gas.

volume =m³ [2]

(ii) Plot a point on Fig. 5.1 to represent the pressure and volume of this gas at 300 K. Label this point A. [1]

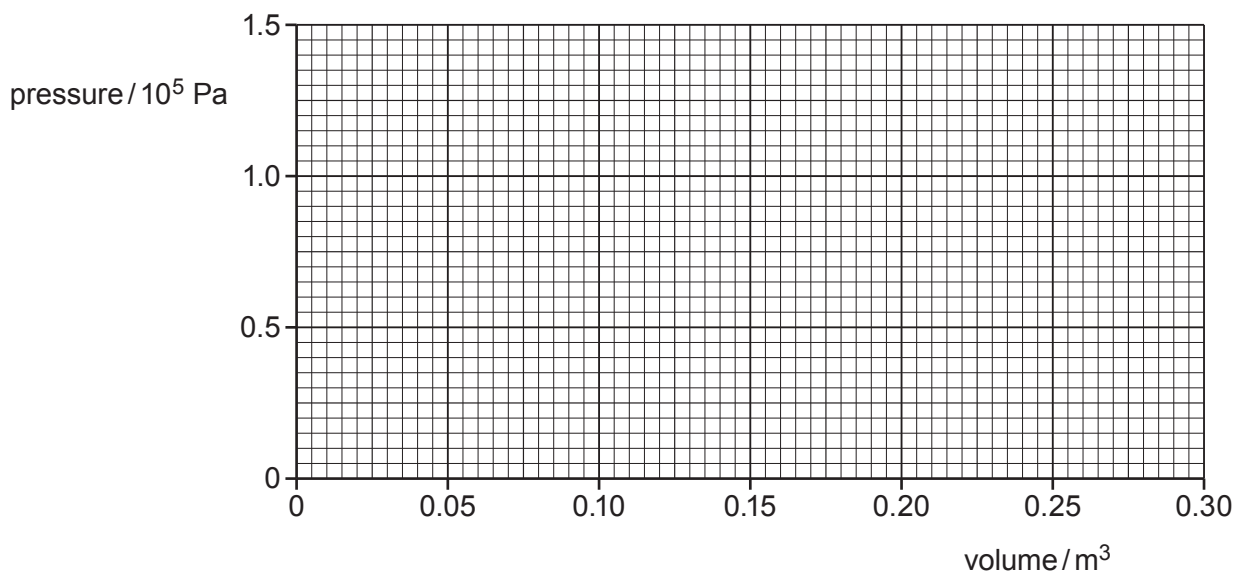

Fig. 5.1

- (iii) On Fig. 5.1, draw a line to indicate how the pressure of the gas varies with its volume for a temperature of 300 K. Label this line B.

[1]

- (d) The gas at point A in (c) is now heated at a constant pressure of $1.00 \times 10^5 \text{ Pa}$ so that its temperature rises from 300 K to 600 K.

- (i) Draw a line on Fig. 5.1 to show this change. Label this line C.

[2]

- (ii) Use your answer in (d)(i) to calculate the work done by the gas during this change.

work done = kJ [2]

- (iii) The total increase in internal energy of the gas during this change is 18.7 kJ.

Determine the amount of thermal energy supplied to the gas.

thermal energy = kJ [2]

[Total: 14]

- 6 A student carries out an investigation that involves measurement of radioactive count rates from solutions of a compound of uranium-238.

Uranium-238 has a half-life of 4.5×10^9 years.

In the first part of the investigation, the student makes up a solution of the compound of known concentration. She measures out a volume of this solution which she knows contains 52 mg of uranium-238. She pours this measured volume into a test-tube.

She then places the test-tube near to a clamped radiation detector and takes repeated measurements of count rate.

She records count rates, in counts per minute (cpm), of 383, 396, 374 and 389.

- (a) (i) Give a reason why it is necessary for the student to take repeat readings of count rate.

.....
.....
..... [1]

- (ii) State **one other** precaution the student must take to ensure that the readings taken are accurate.

.....
.....
..... [1]

- (iii) Calculate the average recorded count rate.

average count rate = cpm [1]

- (iv) Calculate the activity of 52 mg of uranium-238. Give a unit with your answer.

activity = unit [4]

- (v) Estimate the percentage of disintegrations of uranium-238 that are recorded by the radiation detector.

percentage =% [1]

- (b) State one assumption that the estimate in (a)(v) requires.

.....
..... [1]

- (c) The student now replaces the solution of known concentration with a solution of unknown concentration. She takes measurements of count rate from this second solution. Her objective is to determine the mass of uranium-238 in the second solution by comparing the activities of the two solutions.

State two variables that the student must ensure remain constant if she is to be able to compare the two sets of measurements meaningfully.

.....
.....
..... [2]

[Total: 11]

7 (a) State *Hubble's law*.

.....
..... [1]

(b) Explain the principles used by observers on Earth to determine the speeds of distant galaxies.

.....
.....
.....
..... [2]

(c) Describe how observations about distant galaxies provide evidence for

(i) the expanding universe,

.....
.....
..... [2]

(ii) the Big Bang theory.

.....
.....
..... [2]

[Total: 7]

Section 2

Answer any **three** questions in this section.
You are advised to spend about 1 hour 30 minutes on this section.

- 8 (a) A thin uniform rod of length L and mass m is rotated about an axis perpendicular to its length. Fig. 8.1 shows the rod rotated about one end. Fig. 8.2 shows the rod rotated about its centre. Point C shows the position of the centre of mass of the rod.

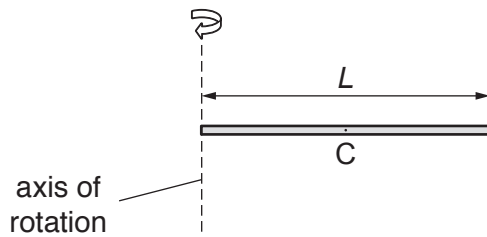

Fig. 8.1

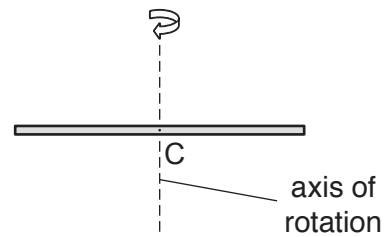

Fig. 8.2

Explain why the moment of inertia of the rod is greater in Fig. 8.1 than in Fig. 8.2.

.....

.....

.....

..... [2]

- (b) The rod, pivoted at the end P, is shown in Fig. 8.3.

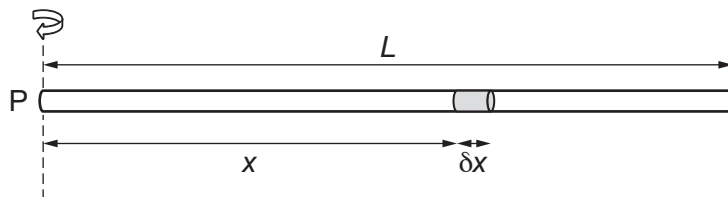

Fig. 8.3

A short section of the rod of length δx is at a distance x from end P.

- (i) Write down an expression for the mass δm of the short section of the rod.

[1]

- (ii) Write down an expression for the moment of inertia δI about point P of this short section.

[1]

- (iii) Show that the moment of inertia of the whole rod about P is given by:

$$I_P = \frac{1}{3}mL^2$$

[4]

- (iv) Using $I_P = \frac{1}{3}mL^2$ or otherwise, derive an expression for the moment of inertia I_C of the rod about its centre of mass.

[2]

- (c) An old street lamp of height 5.0 m and mass 200 kg can be considered to behave like a thin uniform rod PQ of length 5.0 m. The base of the street lamp has corroded and it falls to the ground, pivoting about point P, as shown in Fig. 8.4.

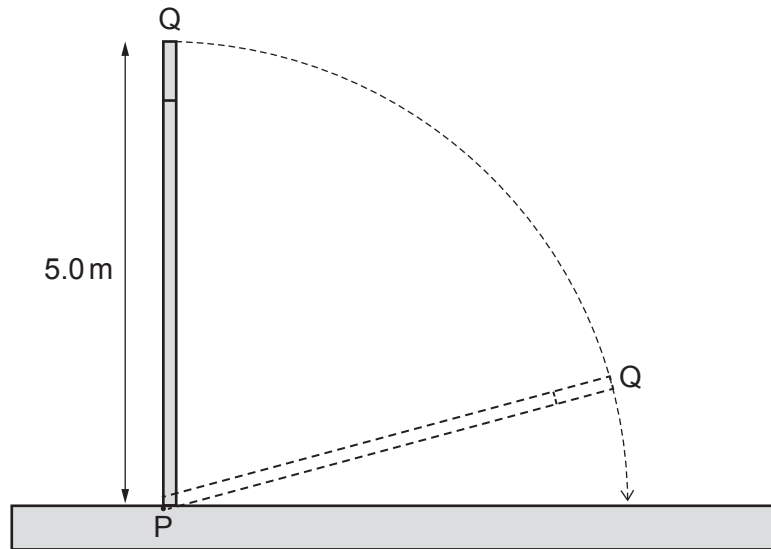

Fig. 8.4

- (i) Determine the change in gravitational potential energy of the street lamp.

change in gravitational potential energy = J [2]

- (ii) By considering conservation of energy, determine the speed at which point Q hits the ground. Assume that the work done against frictional forces is negligible.

speed = ms^{-1} [4]

- (d) A uniform disc of moment of inertia I_{disc} is rotating freely on frictionless bearings about a vertical axis through its centre of mass as shown in Fig. 8.5. The disc has angular velocity ω . A small object of mass m is dropped vertically onto the disc and sticks to it at a distance b from the axis of rotation as shown in Fig. 8.6. The angular velocity of the combined system is now 0.99ω .

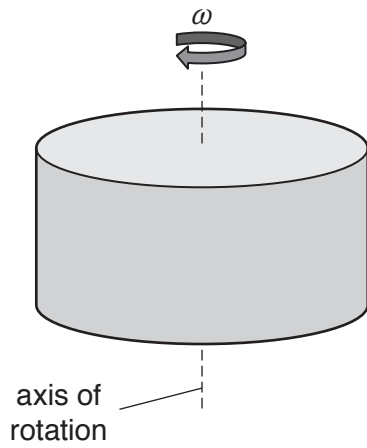

Fig. 8.5

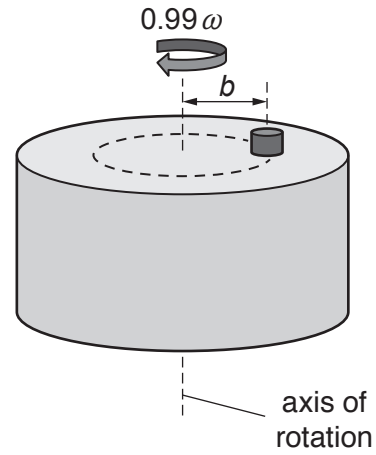

Fig. 8.6

Derive an expression for the moment of inertia I_{disc} in terms of m and b .

[4]

[Total: 20]

- 9 When an earthquake occurs, the waves produced cause surface vibrations. The vibrations can damage buildings far from the epicentre (source) of the earthquake.

The vertical ground vibrations 50 km from a particular earthquake can be modelled by the equation:

$$s = 0.014 \cos (12t)$$

where s is the vertical displacement in metres and t is the time in seconds.

- (a) State the amplitude and frequency of these vibrations.

amplitude =m

frequency = Hz
[2]

- (b) Use differentiation to derive expressions for:

- (i) the vertical velocity v of the ground as these waves pass

[2]

- (ii) the vertical acceleration a of the ground as these waves pass.

[1]

- (c) The U.S. Geological Survey measures Peak Ground Acceleration (PGA) to create an instrumental intensity scale for the effects of earthquakes. This scale is shown in Fig. 9.1.

instrumental intensity scale	PGA / ms^{-2}	maximum ground velocity / ms^{-1}	perceived shaking	potential damage
I	< 0.017	< 0.001	not felt	none
II–III	0.017 – 0.14	0.001 – 0.011	weak	none
IV	0.14 – 0.38	0.011 – 0.034	light	none
V	0.38 – 0.90	0.034 – 0.081	moderate	very light
VI	0.90 – 1.8	0.081 – 0.16	strong	light
VII	1.8 – 3.3	0.16 – 0.31	very strong	moderate
VIII	3.3 – 6.4	0.31 – 0.60	severe	moderate to heavy
IX	6.4 – 12.2	0.60 – 1.16	violent	heavy
X+	> 12.2	> 1.16	extreme	very heavy

Fig. 9.1

Peak Ground Acceleration (PGA) is the maximum acceleration of the ground during an Earthquake.

Assuming that the ground movements can be modelled as simple harmonic oscillations calculate the frequency and the amplitude of the strongest earthquake causing an instrumental intensity scale of V.

frequency = Hz

amplitude = m
[5]

- (d) In reality, earthquakes cause the ground to accelerate in three perpendicular directions, x, y and z, as shown in Fig. 9.2.

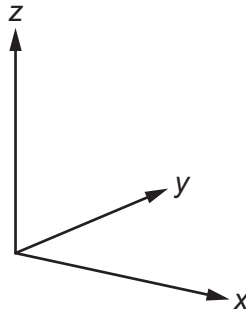

Fig. 9.2

- (i) During a particular earthquake the maximum ground accelerations along x, y and z are:

$$a_x = 8.0 \text{ ms}^{-2}, a_y = a_z = 1.5 \text{ ms}^{-2}$$

Show that the maximum resultant ground acceleration that could be produced by these vibrations is 8.3 ms^{-2} .

[2]

- (ii) State why the maximum resultant ground acceleration might be less than 8.3 ms^{-2} .

.....

.....

..... [1]

- (e) When a building is shaken by an earthquake it vibrates at the same frequency as the ground vibration. However, the amplitude of the building's oscillation can be much larger than the amplitude of the movements of the ground.

- (i) Explain why the building can oscillate with such a large amplitude.

.....

.....

.....

.....

..... [2]

- (ii) State two properties of the building that will affect how strongly it responds to the earthquake vibrations.

.....
 [2]

- (f) It is suggested that the Peak Ground Acceleration decreases with distance r from the epicentre according to the equation $\text{PGA} = \frac{k}{r}$ where k is a constant.

Fig. 9.3 gives some data from an earthquake.

distance r from epicentre / km	56	84	120	220
PGA / ms^{-2}	1.20	0.78	0.53	0.30

Fig. 9.3

Use the data in Fig. 9.3 to explain whether the suggested equation is valid.

[3]

[Total: 20]

- 10 In a model of the hydrogen atom, developed by Bohr, the electron can only orbit the nucleus (a proton) in a set of circular orbits with discrete energy levels E_n given by:

$$E_n = \frac{-13.6 \text{ eV}}{n^2}$$

where n is an integer called the principal quantum number.

- (a) It is possible to interpret n as the number of complete de Broglie waves that fit into one orbit.

- (i) Use this interpretation to show that the angular momentum L of an electron in the n^{th} orbit is given by the expression:

$$L = \frac{nh}{2\pi}$$

[3]

- (ii) A hydrogen atom absorbs a photon and the electron makes a quantum jump from the n^{th} to the $(n+1)^{\text{th}}$ level.

Derive an expression for the change in the angular momentum of the atom.

[1]

- (iii) State and explain what this implies about the angular momentum of the photon.

.....

 [2]

(b) (i) The total energy of an electron in a hydrogen atom is made up of two forms of energy.

State these **two** forms of energy.

.....
 [1]

(ii) Show that, for a circular orbit of radius r , the total energy E is given by:

$$E = \frac{-e^2}{8\pi\epsilon_0 r}$$

[4]

(iii) Explain why the radius of the orbit of an electron in a hydrogen atom can have only certain discrete values.

.....

 [2]

(c) A hydrogen atom in the $n = 2$ state emits a photon and decays to the $n = 1$ state.

Calculate:

(i) the wavelength of the photon emitted

wavelength = m [3]

(ii) the change in radius of the orbit of the electron in this atom.

change in radius = m [4]

[Total: 20]

11 (a) At the end of the nineteenth century most physicists thought that light was an electromagnetic wave consisting of vibrations in a medium called the 'luminiferous aether'.

(i) Suggest a reason why these physicists thought that light needed a medium in which to travel.

.....
.....
..... [1]

(ii) Explain why, if the aether hypothesis were correct, the speed of light measured by different observers who are moving relative to one another would differ.

.....
.....
.....
.....
.....
..... [2]

(b) In 1887 Michelson and Morley carried out an experiment to measure the effect on the speed of light of the Earth's motion through the aether. A beam of monochromatic light was split into two perpendicular beams. These were recombined to form an interference pattern that was viewed with a telescope as shown in Fig. 11.1. The light paths in the experiment are shown in Fig. 11.2.

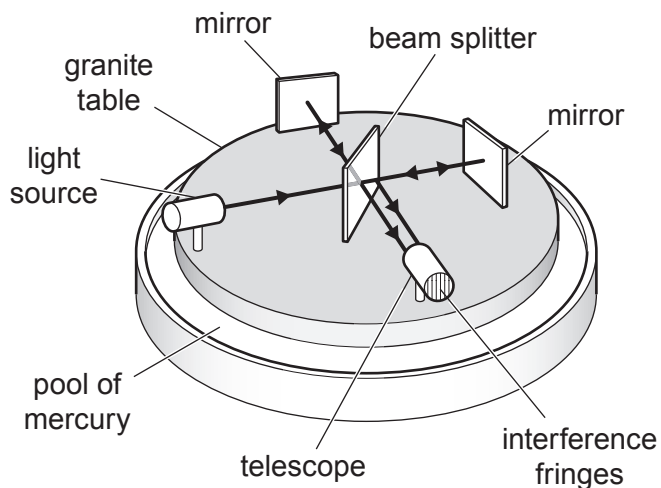

Fig. 11.1

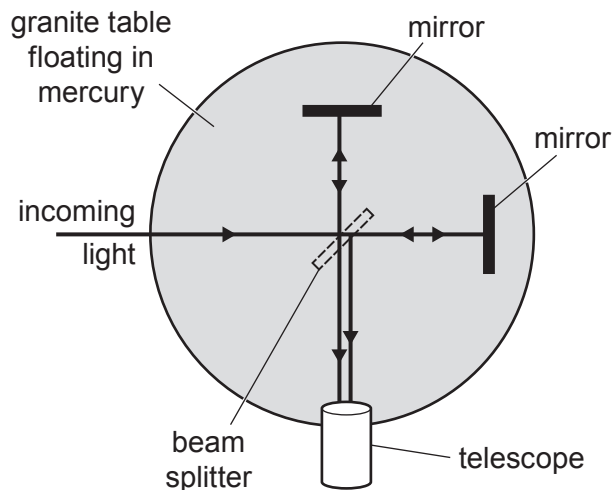

Fig. 11.2

Michelson and Morley expected the interference pattern to change if the apparatus were rotated or if measurements were made at different times in the year.

(i) State what determines the positions of the maxima and minima (interference fringes) in the observed interference pattern.

.....

.....

..... [1]

(ii) Explain why they expected the positions of the interference fringes to change if the apparatus were rotated or if measurements were made at different times in the year.

.....

.....

.....

.....

.....

.....

.....

.....

.....

..... [2]

(iii) State how actual observations compare with the expected observations described in (b)(ii).

.....
..... [1]

(iv) State Einstein's two postulates of special relativity.

postulate 1

postulate 2

[2]

(v) Explain how Einstein's postulates are consistent with the results of experiments such as the one described in (b).

.....
.....
.....
.....
.....
.....
.....
..... [3]

(c) Two clocks, A and B, are in the same inertial reference frame separated by a distance d along the x -axis. They are synchronised in this reference frame. A spacecraft, moving at constant velocity v parallel to the x -axis, passes clock A when it reads time $t = 0$. At this moment an observer inside the spacecraft starts an on-board clock, D.

(i) Write down an expression for the distance between clocks A and B according to the observer inside the spacecraft.

[1]

(ii) Write down an expression for the time on the on-board clock D at the moment the spacecraft passes clock B.

[1]

(iii) Write down an expression for the time on clock B at the moment the spacecraft passes it.

[1]

(iv) Explain why an observer at rest relative to AB and an observer on the spacecraft will disagree about the time shown on clock A at the moment the spacecraft passes clock B.

.....
.....
.....
.....
.....
.....
.....
.....
.....
..... [3]

(d) A photon travels from the Sun to the Earth.

Explain why, in the frame of reference of the photon, the journey is instantaneous.

.....
.....
.....
.....
.....
..... [2]

[Total: 20]

- 12 In 2002 Olaf Nairz, Markus Arndt, and Anton Zeilinger reported that they had carried out a double slit experiment with large molecules (fullerene molecules containing 60 carbon atoms). The set-up of their experiment is shown (simplified) in Fig. 12.1.

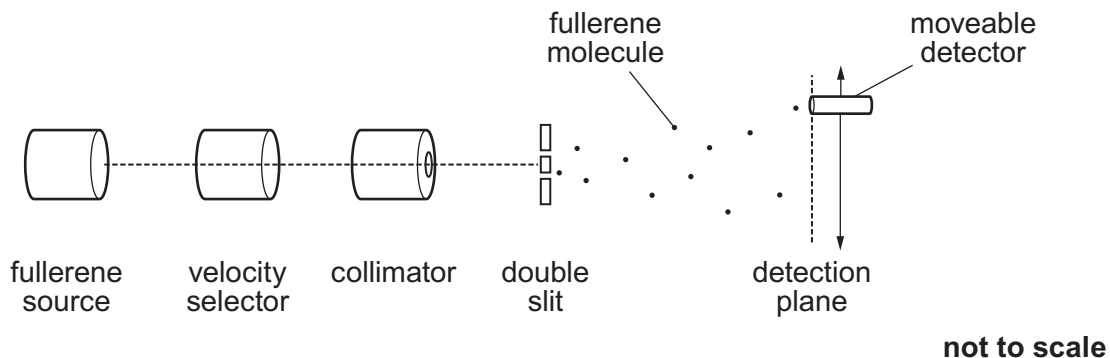

Fig. 12.1

The fullerene source emits molecules with a range of velocities so a velocity selector is used to select molecules with velocities very close to a single value, in this case 200 m s^{-1} . The collimator creates a narrow beam of molecules.

- mass of a fullerene molecule = $1.2 \times 10^{-24} \text{ kg}$
- velocity of molecules emerging from velocity selector = 200 m s^{-1}
- separation of slits in double slit = 100 nm
- distance from double slit to detection plane = 1.2 m

- (a) Explain why it is important, in this experiment, for the molecules reaching the double slit to have a very narrow range of velocities.

.....

 [2]

- (b) Explain why the collimator is necessary.

.....

 [2]

- (c) Calculate the de Broglie wavelength of the fullerene molecules reaching the double slit.

wavelength = m [2]

- (d) The detector was placed at a large number of different positions on the detection plane and in each position it recorded the number of molecules arriving in 50 s. Typical results are shown in Fig. 12.2.

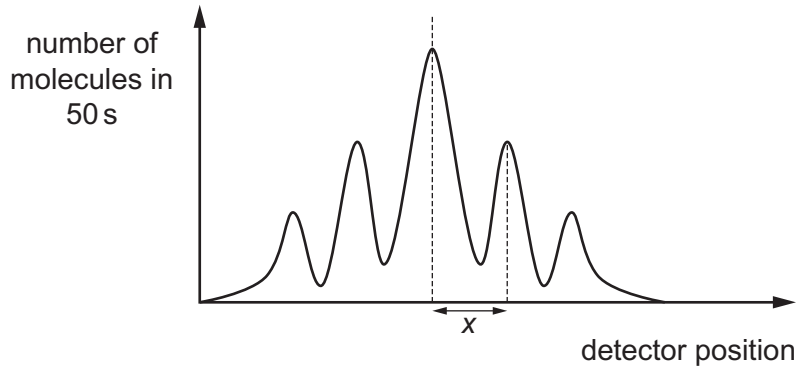

Fig. 12.2

Calculate the expected separation of maxima in the detection plane (shown as x in Fig. 12.2).

$x = \dots\dots\dots$ m [3]

- (e) A double-slit with a slit separation of 100 nm is very difficult to manufacture.

Explain why, nevertheless, it is desirable to make both the slit separation and the molecular velocity as small as possible.

.....

.....

.....

.....

.....

.....

.....

.....

.....

..... [4]

- (f) Fullerene molecules are shaped like tiny footballs and in many circumstances they are treated as particles. The experimenters set up their experiment so that only one molecule at a time was interacting with the double slit. Even so, over a long period of time, the same interference pattern builds up.

Explain how the results of this experiment illustrate that quantum theory is:

- (i) indeterministic

.....
.....
..... [2]

- (ii) non-local.

.....
.....
..... [2]

- (g) Suggest and explain a reason why physicists think it is important to carry out the double slit experiment with ever larger molecules.

.....
.....
.....
.....
.....
.....
.....
.....
.....
.....
..... [3]

[Total: 20]

- 13 (a) (i) A mass of water in the form of steam at 100 °C condenses onto a glass plate and forms water droplets that are also initially at 100 °C. The droplets then cool to a constant temperature of 20 °C.

Add ticks (✓) to Fig. 13.1 to show what happens to the water and to the Universe (including the droplet) during the two stages described above.

condensation at 100 °C	decreases	stays the same	increases
total energy of water			
total entropy of water			
total energy of Universe			
total entropy of Universe			

cooling from 100 °C to 20 °C	decreases	stays the same	increases
total energy of water			
total entropy of water			
total energy of Universe			
total entropy of Universe			

Fig. 13.1

[4]

- (ii) State the second law of thermodynamics in terms of entropy.

.....
 [1]

- (iii) Explain how the overall process described in (a)(i) above is consistent with the second law of thermodynamics.

.....

 [2]

- (b) A heat pump is designed to move heat from one place to another. These can be fitted to houses so that heat from the surrounding air can be used to warm the inside of the house, even if the temperature inside the house is already warmer than the surrounding air.

Fig. 13.2 shows a heat pump working when it is being used to transfer heat from outside to inside a house.

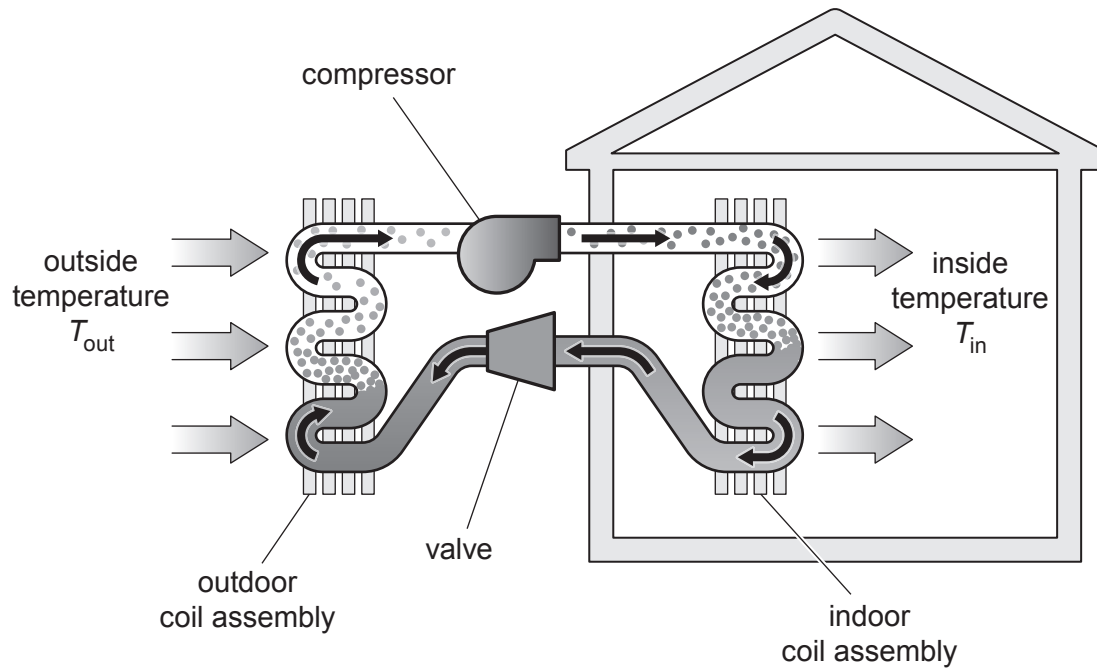

Fig. 13.2

For an ideal heat pump the entropy change when heat Q is taken into or expelled from the pump at temperature T is $\Delta S = \frac{Q}{T}$.

- (i) Show that an ideal heat pump would violate the second law of thermodynamics if the only energy transfer were to transfer heat Q from outside to inside when the outside temperature was lower than the inside temperature.

[3]

- (ii) In practice the heat pump must be supplied with work in order to operate. This additional work is transferred to heat inside the building. Fig. 13.3 shows the energy flow in an ideal heat pump when $T_{\text{in}} > T_{\text{out}}$.

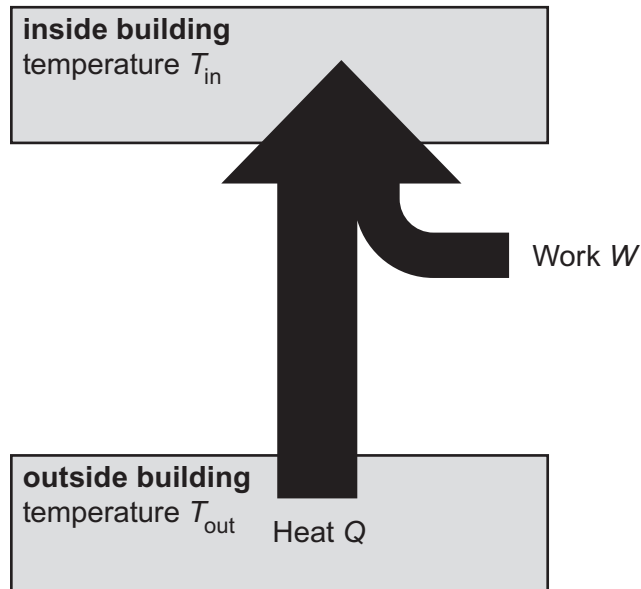

Fig. 13.3

Derive an expression, in terms of Q and the temperatures T_{in} and T_{out} , for the minimum work, W , that must be supplied to the heat pump.

[5]

(c) (i) Explain what is meant by the *thermodynamic arrow of time*.

.....
.....
.....
..... [2]

(ii) Explain why a system in equilibrium cannot be used to determine the direction of time.

.....
.....
.....
..... [2]

(iii) State what (c)(i) and (c)(ii) imply about the present thermodynamic state of the Universe.

.....
..... [1]

[Total: 20]

BLANK PAGE

Permission to reproduce items where third-party owned material protected by copyright is included has been sought and cleared where possible. Every reasonable effort has been made by the publisher (UCLES) to trace copyright holders, but if any items requiring clearance have unwittingly been included, the publisher will be pleased to make amends at the earliest possible opportunity.

To avoid the issue of disclosure of answer-related information to candidates, all copyright acknowledgements are reproduced online in the Cambridge Assessment International Education Copyright Acknowledgements Booklet. This is produced for each series of examinations and is freely available to download at www.cambridgeinternational.org after the live examination series.

Cambridge Assessment International Education is part of the Cambridge Assessment Group. Cambridge Assessment is the brand name of the University of Cambridge Local Examinations Syndicate (UCLES), which itself is a department of the University of Cambridge.