

PART ONE

Mathematics 0580 Formula Sheet Pg 1/9

① Standard Form

$A \times 10^n$
 $1 \leq A < 10$ & n can be +ve or -ve.

Example

Express in standard form:

- a) $321000 = 3.21 \times 10^5$
b) $0.000678 = 6.78 \times 10^{-4}$

② Prime number

Memorise all prime numbers from 2 to 71.

2, 3, 5, 7, 11, 13, 17, 19, 23, 29, 31, 37, 41, 43, 47, 53, 59, 61, 67, 71

③ Upper & Lower Bound

Example

Each of the length is measured correct to the nearest centimetre.

Find:

- (a) the upper bound for the perimeter &
(b) the lower bound for the perimeter.

Answer

- (a) Upper bound \Rightarrow round all reading up by 0.5 cm.

$$10 \text{ cm} \Rightarrow 10.5 \text{ cm}$$

$$5 \text{ cm} \Rightarrow 5.5 \text{ cm}$$

$$\begin{aligned} \text{Perimeter} &= 10.5 + 10.5 + 5.5 + 5.5 \\ &= 32 \text{ cm} \end{aligned}$$

- b) Lower bound \Rightarrow round all reading down by 0.5 cm.

$$10 \text{ cm} \Rightarrow 9.5 \text{ cm}$$

$$5 \text{ cm} \Rightarrow 4.5 \text{ cm}$$

$$\begin{aligned} \text{Perimeter} &= 9.5 + 9.5 + 4.5 + 4.5 \\ &= 38 \text{ cm} \end{aligned}$$

④ Direct & Inverse Proportion

Example 1

x is directly proportional to y .

When $y = 10$, $x = 5$

Find x when $y = 20$.

Answer

$$x = ky$$

$$5 = k(10)$$

$$k = \frac{5}{10} = \frac{1}{2}$$

$$x = \frac{1}{2}y$$

When $y = 20$,

$$x = \frac{1}{2}(20)$$

$$= 10$$

Example 2

x is inversely proportional to y .

When $y = 10$, $x = 2$

Find x when $y = 30$.

Answer

$$x = \frac{k}{y}$$

$$2 = \frac{k}{10}$$

$$k = 2 \times 10$$

$$= 20$$

$$x = \frac{20}{y}$$

When $y = 30$

$$x = \frac{20}{30}$$

$$= \frac{2}{3}$$

⑤ Percentage

Example

Express 64 as a percentage of 80.

Answer

$$\frac{64}{80} \times 100\% = 80\%$$

Mathematics 0580 Formula Sheet Pg 2/9

⑦ Simple & Compound Interest

$$\text{Simple interest (I)} = \frac{PRT}{100}$$

P = principal, R = rate, T = time

Example 1

Calculate the interest owed if a man borrows \$300 from a bank charging 2% simple interest per month for 3 months?

$$P = 300, R = 2\%, T = 3$$

$$I = \frac{300 \times 2 \times 3}{100}$$

$$= \$18$$

Compound Interest

$$A = P \left(1 + \frac{R}{100}\right)^n$$

A = total amount after time, n

P = principal

R = rate

n = time

Example 2

Calculate the total amount owed if a man borrows \$300 from a bank charging 2% compound interest per month for 3 months?

$$P = 300, R = 2, n = 3$$

$$\begin{aligned} \text{Total amount owed} &= P \left(1 + \frac{R}{100}\right)^n \\ &= 300 \left(1 + \frac{2}{100}\right)^3 \\ &= \$318.36 \end{aligned}$$

⑧ Gradient of a straight line

$$\text{Gradient} = \frac{y_1 - y_2}{x_1 - x_2}$$

Example

Calculate the gradient of a line that passes through point A(-2, -1) & B(4, 2)

Answer

$$\begin{array}{cc} A(-2, -1) & B(4, 2) \\ x_1, y_1 & x_2, y_2 \end{array}$$

$$\begin{aligned} \text{Gradient} &= \frac{-1 - 2}{-2 - 4} \\ &= \frac{-3}{-6} \\ &= \frac{1}{2} \end{aligned}$$

⑨ Equation of a line

$$y = mx + c$$

① find the gradient, m.

② find the y-intercept, c.

Example

Find the equation of a line that passes through A(-2, -1) & B(4, 2)

Answer

$$\text{Eqn of a line} \Rightarrow y = mx + c$$

$$m = \frac{1}{2} \text{ (found above)}$$

$$y = \frac{1}{2}x + c$$

To find c, sub in point A.

$$-1 = \frac{1}{2}(-2) + c$$

$$-1 = -1 + c$$

$$c = 0$$

$$y = \frac{1}{2}x + 0$$

$$\Rightarrow y = \frac{1}{2}x$$

Mathematics 0580 Formula Sheet Pg 3/9

⑩ Midpoint of 2 given points

$$\text{Midpoint} = \left(\frac{x_1 + x_2}{2}, \frac{y_1 + y_2}{2} \right)$$

Example

Find the midpoint of $P(-2, 8)$ & $Q(4, -4)$

Answer

$$P(-2, 8) \quad Q(4, -4)$$

$$x_1 \quad y_1 \quad x_2 \quad y_2$$

$$\text{Midpoint} = \left(\frac{-2+4}{2}, \frac{8+(-4)}{2} \right)$$

$$= (1, 2)$$

⑪ Length between 2 points

$$\text{Length} = \sqrt{(x_1 - x_2)^2 + (y_1 - y_2)^2}$$

Example

Find the distance between $P(-2, 8)$ & $Q(4, -4)$

Answer

$$P(-2, 8) \quad Q(4, -4)$$

$$x_1 \quad y_1 \quad x_2 \quad y_2$$

$$\text{Distance} = \sqrt{(-2-4)^2 + (8-(-4))^2}$$

$$= \sqrt{6^2 + 12^2}$$

$$= \sqrt{180}$$

$$= 13.4 \text{ units}$$

⑫ Function

Example

$$f(x) = 4x + 1 \quad g(x) = x^3 + 1$$

$$f(2) \Rightarrow \text{sub } x=2 \text{ \& solve for } f(x)$$

$$f(2) = 4(2) + 1$$

$$= 8 + 1$$

$$= 9$$

$$fg(x) \Rightarrow \text{sub } x = g(x)$$

$$fg(x) = 4(x^3 + 1) + 1$$

$$= 4x^3 + 4 + 1$$

$$= 4x^3 + 5$$

$$f^{-1}(x) \Rightarrow \text{let } y = f(x) \text{ \& make } x \text{ the subj.}$$

$$\text{Let } y = f(x) = 4x + 1$$

$$y = 4x + 1$$

$$4x = y - 1$$

$$x = \frac{y-1}{4}$$

$$f^{-1}(x) = \frac{x-1}{4}$$

⑬ Indices

$$a^m \times a^n = a^{m+n}$$

$$\text{Example: } 3x^5 \times 4x^3 = 12x^{5+3}$$

$$= 12x^8$$

$$a^m \div a^n = a^{m-n}$$

$$\text{Example: } 24x^7 \div 6x^3 = 4x^{7-3}$$

$$= 4x^4$$

$$a^0 = 1$$

$$\text{Example: } 24x^7 \div 3x^7 = 8x^{7-7}$$

$$= 8x^0$$

$$= 8(1)$$

$$= 8$$

Mathematics 0580 Formula Sheet Pg 4/9

$$(a^m)^n = a^{m \times n} = a^{mn}$$

Example: $(3x^2)^4 = 3^4 x^{2 \times 4}$
 $= 81x^8$

$$(a \times b)^n = a^n \times b^n$$

$$\left(\frac{a}{b}\right)^n = \frac{a^n}{b^n}$$

$$a^{-n} = \frac{1}{a^n}$$

Example: $x^2 y^5 \div x^7 y^3 = x^{2-7} y^{5-3}$
 $= x^{-5} y^2$
 $= \frac{1}{x^5} y^2$
 $= \frac{y^2}{x^5}$

$$a^{\frac{1}{n}} = \sqrt[n]{a}, n \neq 0$$

$$a^{\frac{m}{n}} = \sqrt[n]{a^m}, n \neq 0$$

Solving Eqn involving Indices

$$3^x \times 3^2 = 81$$

$$3^{x+2} = 81$$

$$3^{x+2} = 3^4$$

$$x+2 = 4$$

$$x = 4 - 2$$

$$x = 2$$

(14) Solving Quadratic Eqn

- By factorisation

Example: $x^2 - x - 6 = 0$

$$(x-3)(x+2) = 0$$

$$x-3=0 \quad x+2=0$$

$$x=3 \quad x=-2$$

$$\begin{array}{r|l} x & -3 & -3x \\ \hline x & 2 & 2x \\ \hline x^2 & -6 & -x \end{array}$$

- By formula

* When question says "give your answers correct to 2 decimal places.", USE FORMULA *

$$x = \frac{-b \pm \sqrt{b^2 - 4ac}}{2a}$$

(5) Symmetry Properties of Circles

a) Equal chords are equidistant from centre

If $AB = CD \Rightarrow x = y$

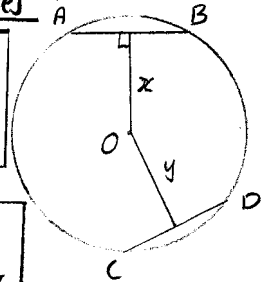

b) Perpendicular bisector of chord passes through centre

c) Tangents from an external point are equal in length $\Rightarrow KP = KQ \Rightarrow x = y$

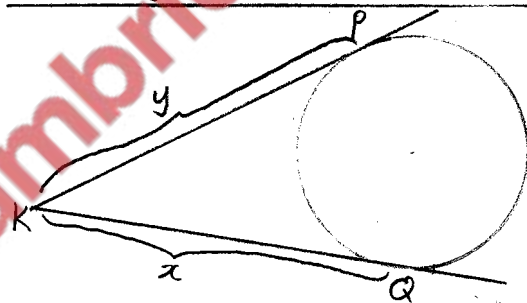

Paper 1 Qn

(16) Angle Properties

a) Angles at a point = 360°

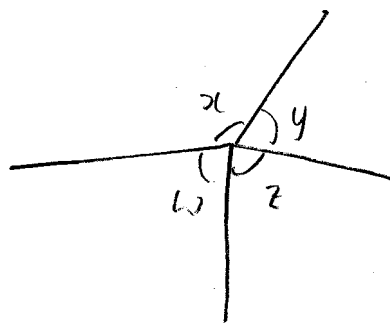

$$\angle w + \angle x + \angle y + \angle z = 360^\circ$$

Mathematics 0580 Formula Sheet Pg 5/9

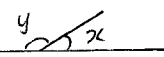

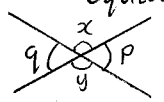
b) Angles on a straight line = 180°
 $\angle x + \angle y = 180^\circ$ 

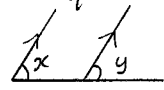
c) Vertically opp. angles are equal.
 $\angle x = \angle y$
 $\angle p = \angle q$ 

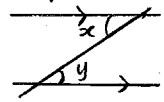
d) Corresponding angles are equal. (F)
 $\angle x = \angle y$ 

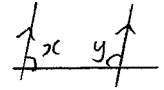
e) Alternate angles are equal (Z)
 $\angle x = \angle y$ 

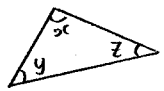
f) Interior angles = 180° (U)
 $\angle x + \angle y = 180^\circ$ 

g) Angles in a $\Delta = 180^\circ$
 $\angle x + \angle y + \angle z = 180^\circ$ 
 Angles in a quadrilateral = 360°
 $\angle w + \angle v + \angle x + \angle y = 360^\circ$

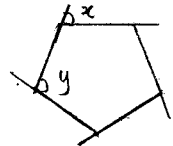
h) Polygons & their angles
 For regular polygon with n sides, ext $\angle = \frac{360^\circ}{n}$
 For regular polygon with n sides, int. $\angle = 180^\circ - \frac{360^\circ}{n}$
Example For a 5-sided polygon, $n = 5$
 ext. $\angle = \angle x = \frac{360^\circ}{5} = 72^\circ$
 int. $\angle = \angle y = 180^\circ - 72^\circ = 108^\circ$

i) Irregular Polygon & their angles
 Total ext. $\angle s = 360^\circ$
 Total interior $\angle s = (n-2) \times 180^\circ$

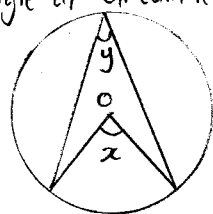
j) Angle at centre = $2 \times$ angle at circumference
 $\angle x = 2 \times \angle y$ 

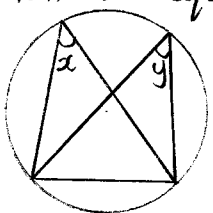
k) Angles in the same segments are equal
 $\angle x = \angle y$ 

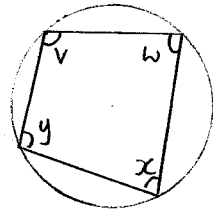
l) Opp $\angle s$ in a cyclic quadrilateral = 180°
 $\angle v + \angle x = 180^\circ$
 $\angle y + \angle w = 180^\circ$ 

⑰ Locus

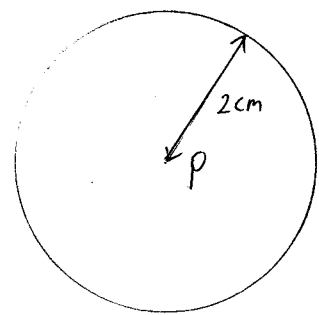
a) Given distance from a given point
 Example: Construct a locus 2cm from P.

Mathematics 0580 Formula Sheet Pg 6/9

b) Given distance from a given line
 Example: construct a locus 2cm from line PQ

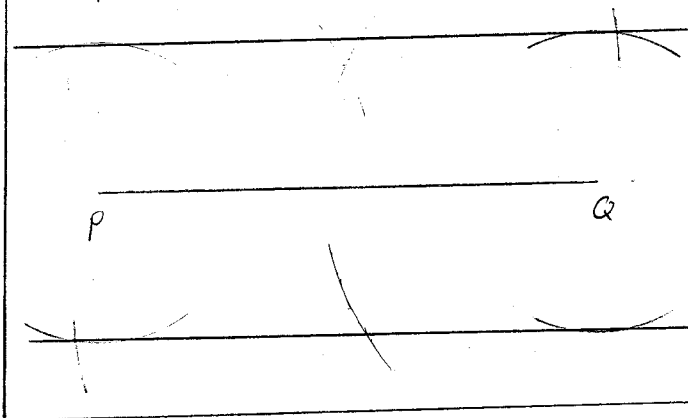

c) Equidistant from 2 given point
 Example: Construct a locus that is equidistant from point P & point Q

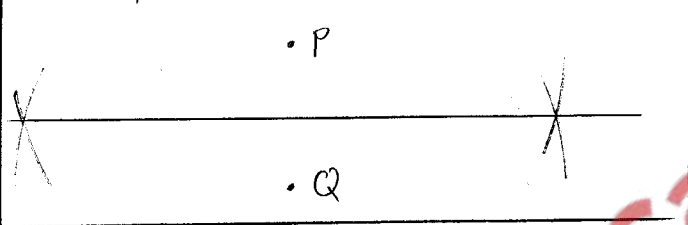

d) Equidistant from 2 given intersecting lines
 Example: Construct a locus equidistant from PQ & MN.

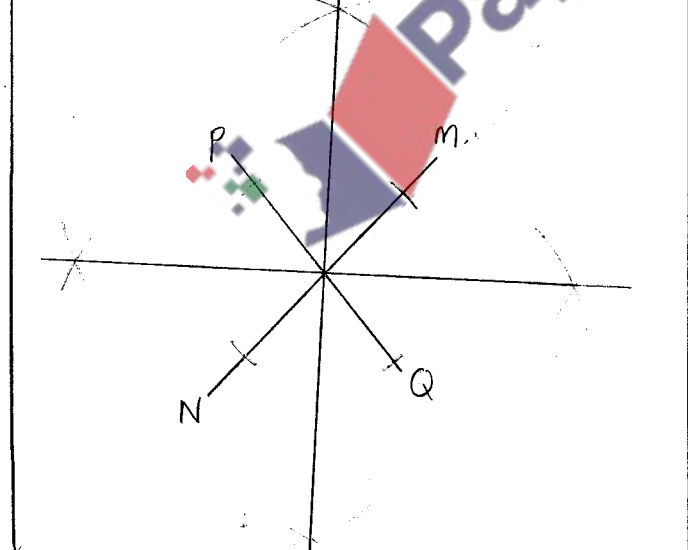

⑧ Mensuration

- a) Circumference of circle = $2\pi r$
- b) Area of circle = πr^2
- c) Area of parallelogram = Length \times height
- d) Area of trapezium = $\frac{1}{2} (l_1 + l_2) \times$ height
- e) Volume of a cuboid = $l \times b \times h$
- f) Volume of prism = surface area \times height
- g) Volume of cylinder = $\pi r^2 h$
- h) Surface area of cuboid = $2(lb) + 2(bh) + 2(lh)$
- i) Surface area of cylinder = $2\pi r^2 + 2\pi r h$
- j) Arc length = $\frac{\theta}{360} \times 2\pi r$
- k) Area of sector = $\frac{\theta}{360} \times \pi r^2$

⑨ Trigonometry

Right-angled triangle

a) $a^2 + b^2 = c^2$

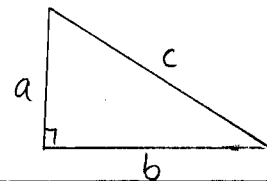

b) TOA CAH SOH

$\tan x = \frac{\text{OPP}}{\text{adj}}$

$\cos x = \frac{\text{adj}}{\text{hyp}}$

$\sin x = \frac{\text{OPP}}{\text{hyp}}$

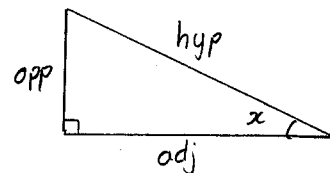

Not a right-angled triangle

c) Area of $\Delta = \frac{1}{2} a b \sin C$

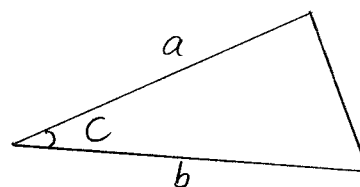

Mathematics 0580 Formula Sheet Pg 7/9

d) Sine Rule

$$\frac{a}{\sin A} = \frac{b}{\sin B}$$

When to use?

- ① Given 2 side & 1 angle, find last angle
- ② Given 2 angle & 1 side, find last side

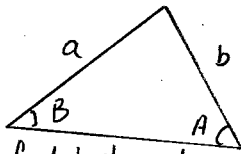

e) Cosine Rule

$$c^2 = a^2 + b^2 - 2ab \cos C$$

When to use?

- ① Given 2 sides & 1 angle, find last side
- ② Given 3 sides, find angle

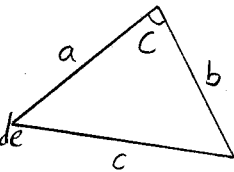

b) For histogram,

$$\text{Frequency density} = \frac{\text{frequency}}{\text{width}}$$

② Probability

If we call a particular event 'A' then the probability of 'A' happening is

$$P(A) = \frac{\text{Number of different way A can happen}}{\text{Total number of outcomes}}$$

The 'and' rule

$$P(A \text{ and } B) = P(A) \times P(B)$$

The 'or' rule

$$P(A \text{ or } B) = P(A) + P(B)$$

② Statistics

a) Mode, median & mean

Example: normal die, numbered 1 to 6, rolled 50 times

Score	1	2	3	4	5	6
Frequency	15	10	7	5	6	7

Mode = 15 \Rightarrow score with highest frequency

Median \Rightarrow score in the middle position.

$$\frac{50+1}{2} = 25.5 \Rightarrow 25^{\text{th}} \text{ \& } 26^{\text{th}} \text{ position}$$

$$\text{median} = \frac{2+3}{2}$$

$$= 2.5$$

$$\text{Mean} = \frac{\text{total score}}{\text{frequency}}$$

$$= \frac{1 \times 15 + 2 \times 10 + 3 \times 7 + 4 \times 5 + 5 \times 6 + 6 \times 7}{50}$$

$$= 2.96$$

② Matrices

For a matrix, $A = \begin{bmatrix} a & b \\ c & d \end{bmatrix}$

$$\text{determinant } A = ad - bc$$

$$A^{-1} = \frac{1}{ad-bc} \begin{bmatrix} d & -b \\ -c & a \end{bmatrix}$$

Example: Find A^{-1} of $A = \begin{bmatrix} -6 & 7 \\ -4 & 3 \end{bmatrix}$

$$A^{-1} = \frac{1}{(-6)(3) - (7)(-4)} \begin{bmatrix} 3 & -7 \\ 4 & -6 \end{bmatrix}$$

$$= \frac{1}{-18 + 28} \begin{bmatrix} 3 & -7 \\ 4 & -6 \end{bmatrix}$$

$$= \frac{1}{10} \begin{bmatrix} 3 & -7 \\ 4 & -6 \end{bmatrix}$$

$$= \begin{bmatrix} \frac{3}{10} & -\frac{7}{10} \\ \frac{2}{5} & -\frac{3}{5} \end{bmatrix}$$

Mathematics 0580 Formula Sheet Pg 8/9

23 Transformation

a) Reflection

Example: Describe transformation T to U

Reflection [1 mark]

$y = x$ [1 mark]

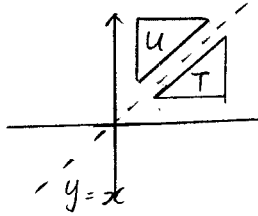

b) Rotation

Example: Describe transformation T to U

Rotation [1 mark]

Centre (0,0) [1 mark]

180° [1 mark]

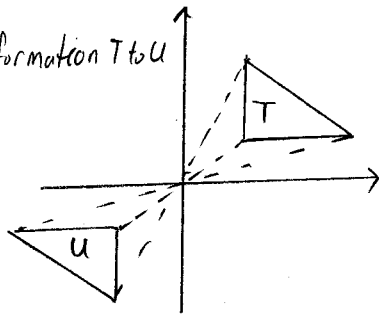

c) Translation

Example: describe the transformation T to U

Translation [1 mark]

$\begin{pmatrix} 3 \\ -5 \end{pmatrix}$ [1 mark]

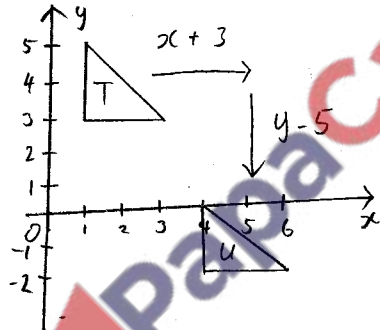

d) Enlargement

Example: describe the transformation T to U

Enlargement [1 mark]

Centre (0,0) [1 mark]

⇒ Draw 2 lines AA' & BB' interception is the centre

$$\begin{aligned} \text{scale factor} &= \frac{OA'}{OA} \\ &= \frac{4}{2} \\ &= 2 \end{aligned}$$

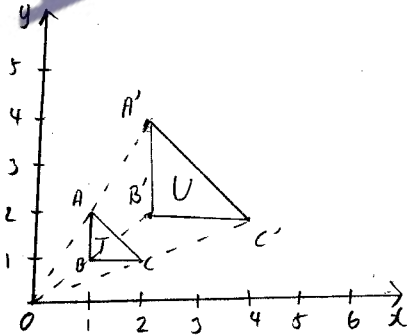

e) Shearing

Example:

Describe the transformation T to U

Shearing [1 mark]

Invariant line, y-axis [1 mark]

shear factor = -1

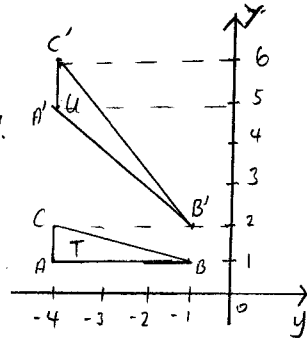

How to find invariant line?

- ① Draw 2 lines AB & A'B' & find interception point 1
- ② Draw 2 lines CB & C'B' & find interception point 2.
- ③ Connect interception point 1 & 2 to get invariant line.

How to find shear factor?

$$\text{shear factor} = \frac{\text{distance from invariant to old pt.}}{\text{distance old point to new pt.}}$$

- Note:
- dist to the left ⇒ -ve
 - " " " right ⇒ +ve
 - dist upward ⇒ +ve
 - dist downward ⇒ -ve

f) Stretching

Example: Describe transformation T to U

Stretching [1 mark]

invariant [1 mark]

x-axis

stretch factor

$$\begin{aligned} &= \frac{\text{invariant to new pt}}{\text{invariant to old pt}} \\ &= \frac{6}{3} \\ &= 2 \end{aligned}$$

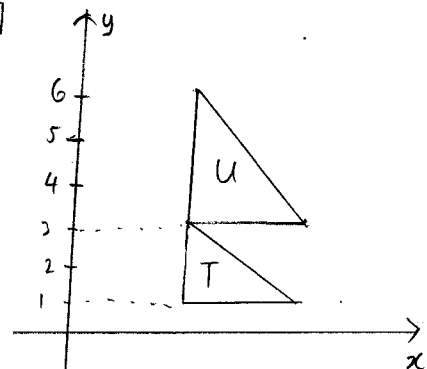

② Similar Figures.

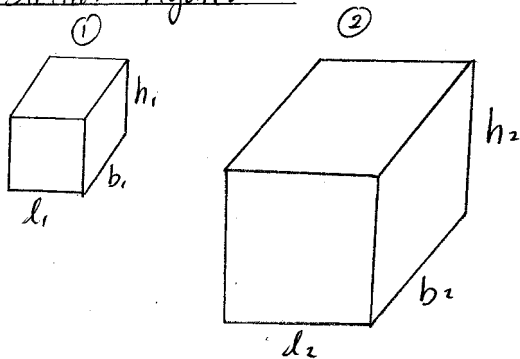

$$a) \left(\frac{l_1}{l_2}\right) = \left(\frac{b_1}{b_2}\right) = \left(\frac{h_1}{h_2}\right)$$

$$b) \frac{A_1}{A_2} = \left(\frac{l_1}{l_2}\right)^2$$

$$c) \frac{V_1}{V_2} = \left(\frac{l_1}{l_2}\right)^3$$



PapaCambridge

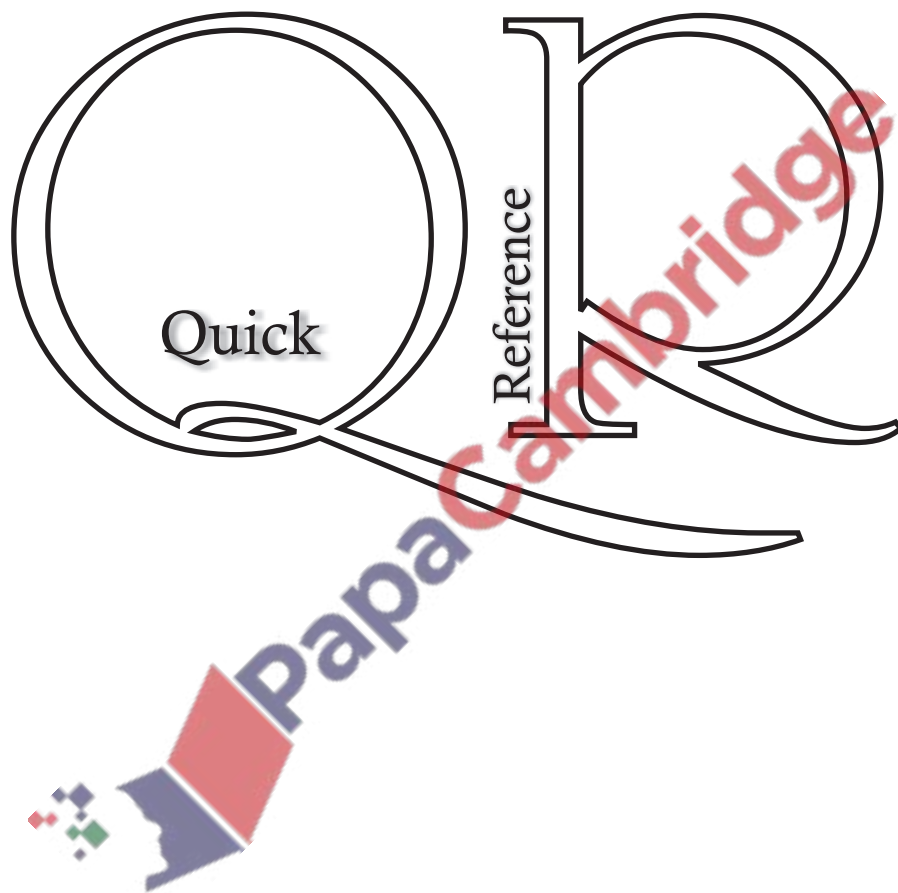

Mathematics

Important points and formulas

Third Edition (May 2009)

Content

No.	Topic / sub topic	Page
1	Natural numbers	1
2	Whole Numbers	1
3	Integers	1
4	Rational Numbers	1
5	Irrational Numbers	1
6	Terminating Decimals	1
7	Recurring Decimals	1
8	Significant figures	1
9	Decimal Places	1
10	Standard Form	1
11	Conversion Factors	2
12	Time	2
13	Percentages	2
14	Simple Interest	2
15	Compound Interest	2
16	Speed, Distance and Time	3
17	Quadratic Equations	3
18	Expansion of algebraic expressions	3
19	Factorization of algebraic expressions	3
20	Ordering	3
21	Variation	4
22	PYTHAGORAS' THEOREM	4
23	Area and Perimeter	4
24	Surface Area and Volume	5
25	Angles on a straight line	6
26	Vertically opposite angles	6
27	Different types of triangles	6
28	Parallel Lines	6
29	Types of angles	6
30	Angle properties of triangle	7
31	Congruent Triangles	7
32	Similar Triangles	7
33	Areas of Similar Triangles	8
34	Polygons	8
35	Similar Solids	8
36	CIRCLE	9
37	Chord of a circle	9
38	Tangents to a Circle	10
39	Laws of Indices	10
40	Solving Inequalities	11
41	TRIGONOMETRY	11
42	Bearing	11
43	Cartesian co-ordinates	12
44	Distance – Time Graphs	12
45	Speed – Time Graphs	12
46	Velocity	13
47	Acceleration	13
48	SETS	13

49	Loci and construction	14
50	Vectors	14
51	Column Vectors	15
52	Parallel Vectors	15
53	Modulus of a Vector	15
54	MATRICES	15
55	The Inverse of a Matrix	15
56	Transformations	16 -17
57	Transformation by Matrices	18
58	STATISTICS	19
59	Probability	20
60	Symmetry	21

NUMBER

Natural Numbers: Numbers which are used for counting purpose are called natural numbers.

Ex: 1, 2, 3, 4,100,

Whole Numbers: Natural numbers including 0 are called Whole Numbers.

Ex: 0, 1, 2, 3, 4,

Integers: Positive natural numbers, negative natural numbers along with 0 are called integers.

Ex.:, -4, -3, -2, -1, 0, 1, 2, 3, 4,

Rational Numbers: Numbers which are in the form of $\frac{p}{q}$ ($q \neq 0$) where p and q are positive or negative whole numbers are called rational numbers.

Ex: $\frac{1}{2}$, $\frac{3}{4}$, $\frac{-5}{7}$, $\frac{49}{-56}$

Irrational Numbers: Numbers like $\sqrt{2}$, π cannot be expressed as rational numbers. Such types of numbers are called as irrational numbers.

Ex: $\sqrt{5}$, $\sqrt{17}$,

Terminating Decimals

These are decimal numbers which stop after a certain number of decimal places.

For example, $7/8 = 0.875$, is a terminating decimal because it stops (terminates) after 3 decimal places.

Recurring Decimals

These are decimal numbers which keep repeating a digit or group of digits; for example $137/259 = 0.528\ 957\ 528\ 957\ 528\ 957\ \dots$, is a recurring decimal. The six digits 528957 repeat in this order. Recurring decimals are written with dots over the first and last digit of the repeating digits, e.g. $0.\dot{5}28\ 95\dot{7}$

- The order of operations follows the **BODMAS** rule:

Brackets
Powers Of
Divide
Multiply
Add
Subtract

- Even numbers:** numbers which are divisible by 2, eg, 2, 4, 6, 8, ...
- Odd numbers:** numbers which are not divisible by 2, eg; 1, 3, 5, 7 ...

- Real numbers** are made up of all possible *rational* and *irrational* numbers.
- An **integer** is a whole number.
- A **prime number** is divisible only by itself and by one (1). 1 is not a prime number. It has only two factors. 1 and the number itself.
- The exact value of **rational** number can be written down as the ratio of two whole numbers.
- The exact value of an **irrational** number cannot be written down.
- A **square number** is the result of multiplying a number by itself.
Ex: $1^2, 2^2, 3^2, \dots$ i.e. 1, 4, 9,
- A **cube number** is the result of multiplying a number by itself three times.
Ex: $1^3, 2^3, 3^3, \dots$ i.e. 1, 8, 27,
- The **factors** of a number are the numbers which divide exactly into two.
eg. Factors of 36
1, 2, 3, 4, 6, 9, 12, 18
- Multiples** of a number are the numbers in its times table.
eg. Multiples of 6 are 6, 12, 18, 24, 30, ...

Significant figures;

Example;

$8064 = 8000$ (correct to 1 significant figures)
 $8064 = 8100$ (correct to 2 significant figures)
 $8064 = 8060$ (correct to 3 significant figures)
 $0.00508 = 0.005$ (correct to 1 significant figures)
 $0.00508 = 0.0051$ (correct to 2 significant figures)
 $2.00508 = 2.01$ (correct to 3 significant figures)

Decimal Places

Example

$0.0647 = 0.1$ (correct to 1 decimal places)
 $0.0647 = 0.06$ (correct to 2 decimal places)
 $0.0647 = 0.065$ (correct to 3 decimal places)
 $2.0647 = 2.065$ (correct to 3 decimal places)

Standard Form:

The number $a \times 10^n$ is in standard form when $1 \leq a < 10$ and n is a positive or negative integer.

Eg: $2400 = 2.4 \times 10^3$
 $0.0035 = 3.5 \times 10^{-3}$

Conversion Factors:

Length:

$$1 \text{ km} = 1000 \text{ m}$$

$$1 \text{ m} = 100 \text{ cm}$$

$$1 \text{ cm} = 10 \text{ mm}$$

km means kilometer
m means meter
cm means centimeter
mm means millimeter

Mass:

$$1 \text{ kg} = 1000 \text{ gm}$$

$$1 \text{ gm} = 1000 \text{ mgm}$$

$$1 \text{ tonne} = 1000 \text{ kg}$$

where kg means kilogram

gm means gram

mgm means milligram

Volume:

$$1 \text{ litre} = 1000 \text{ cm}^3$$

$$1 \text{ m}^3 = 1000 \text{ litres}$$

$$1 \text{ kilo litre} = 1000 \text{ litre}$$

$$1 \text{ dozen} = 12$$

Time:

$$1 \text{ hour} = 60 \text{ minutes} = 3600 \text{ seconds}$$

$$1 \text{ minute} = 60 \text{ seconds.}$$

$$1 \text{ day} = 24 \text{ hours}$$

$$1 \text{ year} = 12 \text{ months}$$

$$= 52 \text{ weeks}$$

$$= 365.25 \text{ days.}$$

$$1 \text{ week} = 7 \text{ days}$$

$$1 \text{ leap year} = 366 \text{ days}$$

$$1 \text{ light year} = 9.46 \times 10^{12} \text{ km.}$$

Percentages:

- Percent means per hundred.
- To express one quantity as a percentage of another, first write the first quantity as a fraction of the second and then multiply by 100.
- Profit = S.P. – C.P.
- Loss = C.P. – S.P.
- Profit percentage = $\frac{SP-CP}{CP} \times 100$
- Loss percentage = $\frac{CP-SP}{CP} \times 100$

where CP = Cost price and SP = Selling price

Simple Interest:

To find the interest:

- $i = \frac{PRT}{100}$ where
P = money invested or borrowed
R = rate of interest per annum
T = Period of time (in years)

To find the amount:

- $A = P + I$ where *A* = amount

Compound Interest:

$$A = p \left(1 + \frac{r}{100} \right)^n$$

Where,

A stands for the amount of money accruing after *n* year.

P stands for the principal

R stands for the rate per cent per annum

n stands for the number of years for which the money is invested.

Speed, Distance and Time:

- Distance = speed x time

$$\bullet \text{ Speed} = \frac{\text{distance}}{\text{time}}$$

$$\bullet \text{ Time} = \frac{\text{distance}}{\text{Speed}}$$

$$\bullet \text{ Average speed} = \frac{\text{total distance}}{\text{total time}}$$

- Units of speed: km/hr, m/sec
- Units of distance: km, m
- Units of time: hr, sec

$$\bullet \text{ km / hr} \times \frac{5}{18} = \text{m / sec}$$

$$\bullet \text{ m / sec} \times \frac{18}{5} = \text{km / hr}$$

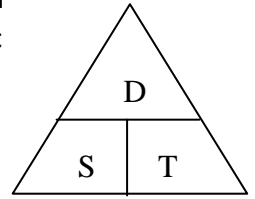

ALGEBRA

Quadratic Equations:

An equation in which the highest power of the variable is 2 is called quadratic equation. Thus $ax^2 + bx + c = 0$ where a, b, c are constants and $a \neq 0$ is a general equation.

Solving quadratic equations:

We can solve quadratic equation by method of,

- Factorization
- Using the quadratic formula
- Completing the square

(a) Solution by factors:

Consider the equation $c \times d = 0$, where c and d are numbers. The product $c \times d$ can only be zero if either c or d (or both) is equal to zero.

i.e. $c = 0$ or $d = 0$ or $c = d = 0$.

(b) Solution by formula:

The solutions of the quadratic equation $ax^2 + bx + c = 0$ are given by the formula:

$$x = \frac{-b \pm \sqrt{b^2 - 4ac}}{2a}$$

(c) Completing the square

- Make the coefficient of x^2 , i.e. $a = 1$
- Bring the constant term, i.e. c to the right side of equation.
- Divide coefficient of x , i.e. by 2 and add the square i.e. $(\frac{b}{2})^2$ to both sides of the equation.
- Factorize and simplify answer

Expansion of algebraic expressions

- $a(b + c) = ab + ac$
- $(a + b)^2 = a^2 + 2ab + b^2$
- $(a - b)^2 = a^2 - 2ab + b^2$
- $a^2 + b^2 = (a + b)^2 - 2ab$
- $a^2 - b^2 = (a + b)(a - b)$

Factorization of algebraic expressions

- $a^2 + 2ab + b^2 = (a + b)^2$
- $a^2 - 2ab + b^2 = (a - b)^2$
- $a^2 - b^2 = (a + b)(a - b)$

Ordering:

= is equal to

≠ is not equal to

> is greater than

≥ is greater than or equal to

< is less than

≤ is less than or equal to

Variation:

Direct Variation:

y is proportional to x

$$y \propto x$$

$$y = kx$$

Inverse Variation:

y is inversely proportional to x

$$y \propto \frac{1}{x}$$

$$y = \frac{k}{x}$$

MENSURATION

PYTHAGORAS' THEOREM

For all the **right angled** triangles “ the square on the hypotenuse is equal to the sum of the squares on the other two sides”

$$c^2 = a^2 + b^2$$

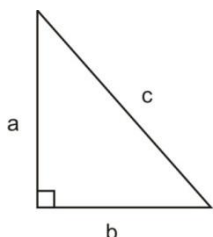

$$c = \sqrt{a^2 + b^2}$$

$$b = \sqrt{c^2 - a^2}$$



$$a = \sqrt{c^2 - b^2}$$

Area and Perimeter:

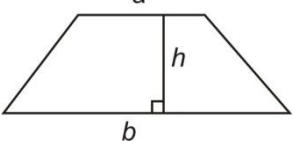
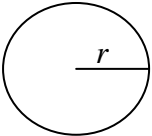
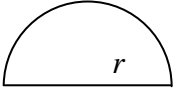
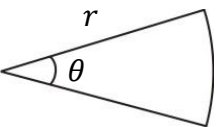
Figure	Diagram	Area	Perimeter
Rectangle		Area = $l \times b$	perimeter = $2(l + b)$
Square		Area = side \times side = $a \times a$	perimeter = $4 \times$ side = $4 \times a$
Parallelogram		Area = $b \times h$	perimeter = $2(a + b)$
		Area = $ab \sin \theta$ where a, b are sides and θ is the included angle	
Triangle		Area = $\frac{1}{2} \times \text{base} \times \text{height}$	perimeter = $a + b + c$
		Area = $\frac{1}{2} ab \sin C$	
		$= \sqrt{s(s-a)(s-b)(s-c)}$ where $s = \frac{a+b+c}{2}$	

Trapezium		Area = $\frac{1}{2}(a + b)h$	perimeter = Sum of all sides
Circle		Area = πr^2	circumference = $2\pi r$
Semicircle		Area = $\frac{1}{2}\pi r^2$	perimeter = $\frac{1}{2}\pi d + d$
Sector		Area = $\pi r^2 \times \frac{\theta}{360}$	length of an arc = $2\pi r \times \frac{\theta}{360}$

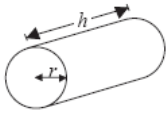
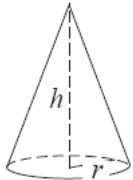
Surface Area and Volume:

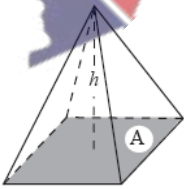
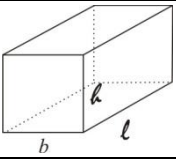
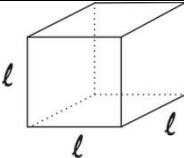
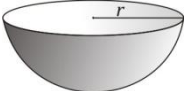
Figure	Diagram	Surface Area	Volume
Cylinder		curved surface area = $2\pi rh$ total surface area = $2\pi r(h + r)$	Volume = $\pi r^2 h$
Cone		curved surface area = πrl where $l = \sqrt{r^2 + h^2}$ total surface area = $\pi r(l + r)$	Volume = $\frac{1}{3}\pi r^2 h$
Sphere		Surface area = $4\pi r^2$	Volume = $\frac{4}{3}\pi r^3$
Pyramid		Base area + area of the shapes in the sides	Volume = $\frac{1}{3} \times \text{base area} \times \text{perpendicular height}$
Cuboid		Surface area = $2(lb + bh + lh)$	Volume = $l \times b \times h$
Cube		Surface area = $6l^2$	Volume = l^3
Hemisphere		Curved surface area = $2\pi r^2$	Volume = $\frac{2}{3}\pi r^3$

GEOMETRY

(a) Angles on a straight line

The angles on a straight line add up to 180° .

$$x + y + z = 180^\circ$$

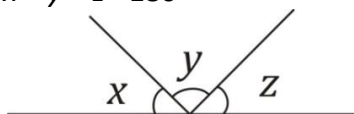

(b) Angle at a point

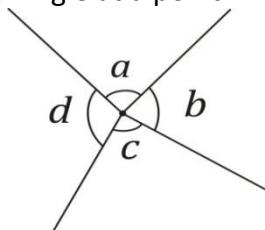

The angles at a point add up to 360° .

$$a + b + c + d = 360^\circ$$

(c) Vertically opposite angles

If two straight lines intersect, then

$$a = c$$

$$b = d \text{ (Vert. opp. } \angle\text{s)}$$

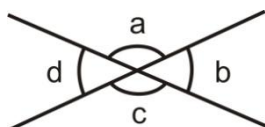

Parallel Lines:

When lines never meet, no matter how far they are extended, they are said to be parallel.

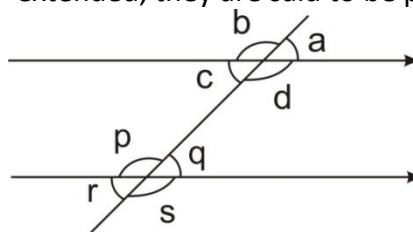

- Vertically opposite angles are equal.
 $a = c$; $b = d$; $p = s$ and $q = r$
- **Corresponding angles** are equal.
 $a = q$; $b = p$; $c = r$ and $d = s$
- **Alternate angles** are equal.
 $c = q$ and $d = p$.
- Sum of the angles of a triangle is 180° .
- Sum of the angles of a quadrilateral is 360° .

Types of angles

Given an angle θ , if

$\theta < 90^\circ$, then θ is an **acute** angle

$90^\circ < \theta < 180^\circ$, then θ is an **obtuse** angle

$180^\circ < \theta < 360^\circ$, then θ is an **reflex** angle

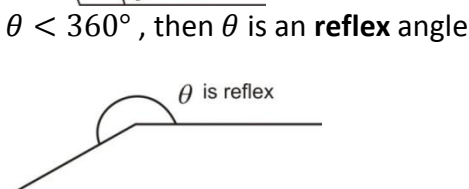
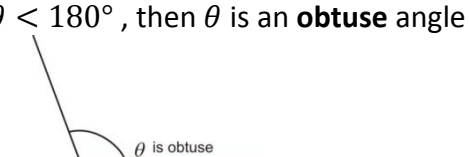
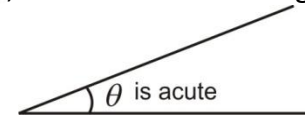

Triangles

Different types of triangles:

1. An isosceles triangle has 2 sides and 2 angles the same.

$$AB = AC$$

$$ABC = BCA$$

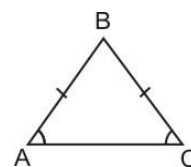

2. An equilateral triangle has 3 sides and 3 angles the same.

$$AB = BC = CA \text{ and } ABC = BCA = CAB$$

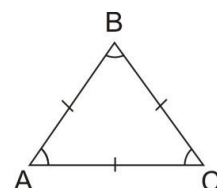

3. A triangle in which one angle is a right angle is called the right angled triangle.

$$ABC = 90^\circ$$

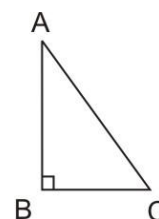

Angle properties of triangle:

- The sum of the angles of a triangle is equal to 180° .
- In every triangle, the greatest angle is opposite to the longest side. The smallest angle is opposite to the shortest side.
- Exterior angle is equal to the sum of the opposite interior angles.

$$x = a + b$$

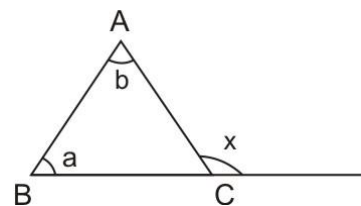

Congruent Triangles:

Two triangles are said to be congruent if they are equal in every aspect.

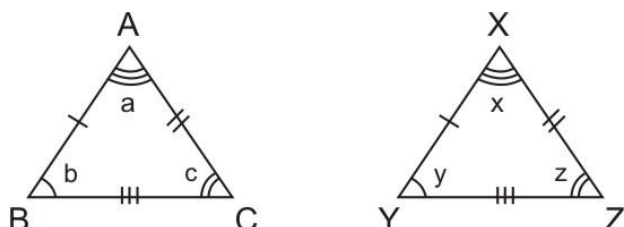

$$\begin{aligned} AB &= XY \\ BC &= YZ \\ AC &= XZ \end{aligned}$$

$$\begin{aligned} \angle a &= \angle x \\ \angle b &= \angle y \\ \angle c &= \angle z \end{aligned}$$

Similar Triangles:

If two triangles are similar then they have a pair of corresponding equal angles and the three ratios of corresponding sides are equal.

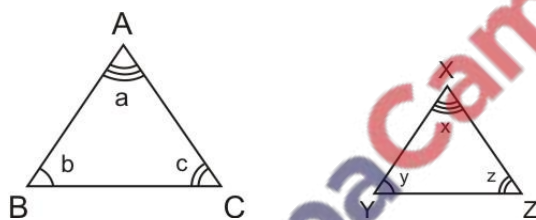

$$\angle a = \angle x; \angle b = \angle y \text{ and } \angle c = \angle z$$

$$\frac{AB}{XY} = \frac{BC}{YZ} = \frac{AC}{XZ}$$

If you can show that one of the following conditions is true for two triangles, then the two triangles are similar.

- i) The angles of one triangle are equal to the corresponding angles of the other triangle.

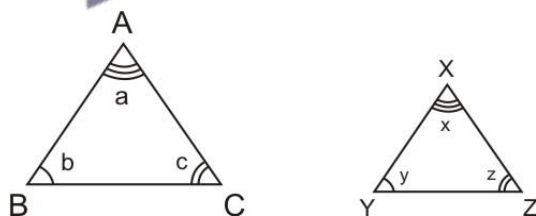

ΔABC is similar to ΔXYZ because $\angle a = \angle x; \angle b = \angle y$ and $\angle c = \angle z$

- ii) The ratio of corresponding sides is equal.

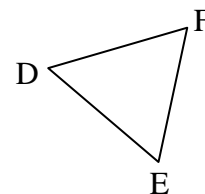
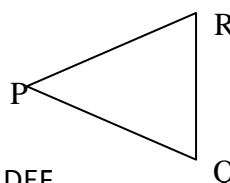

$$\text{If } \frac{PQ}{DE} = \frac{PR}{DF} = \frac{QR}{EF} \text{ then } \Delta PQR \text{ is similar to } \Delta DEF$$

iii) The ratios of the corresponding sides are equal and the angles between them are equal.

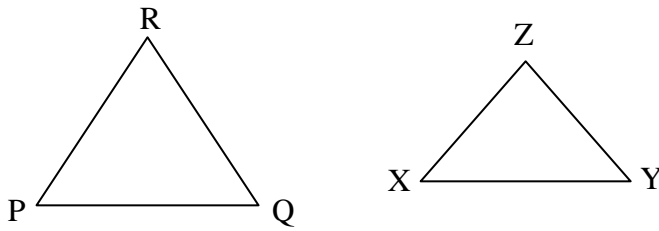

ΔPQR is similar to ΔXYZ (if, for eg: $\angle P = \angle X$ and $\frac{PQ}{XY} = \frac{PR}{XZ}$)

Areas of Similar Triangles:

The ratio of the areas of similar triangles is equal to the ratio of the square on corresponding sides.

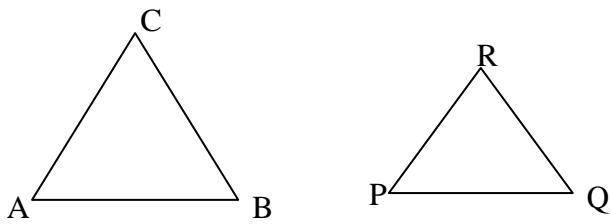

$$\frac{\text{area of } \Delta ABC}{\text{area of } \Delta PQR} = \frac{AB^2}{PQ^2} = \frac{BC^2}{QR^2} = \frac{AC^2}{PR^2}$$

Polygons:

- The exterior angles of a polygon add up to 360° .
- The sum of the interior angles of a polygon is $(n - 2) \times 180^\circ$ where n is the number of sides of the polygon.
- A regular polygon has equal sides and equal angles.
- If the polygon is regular and has n sides, then each exterior angle = $\frac{360}{n}$
-

3 sides = triangle	4 sides = quadrilateral	5 sides = pentagon
6 sides = hexagon	7 sides = heptagon	8 sides = octagon
9 sides = nonagon	10 sides = decagon	

Similar Solids:

If two objects are similar and the ratio of corresponding sides is k , then

- the ratio of their areas is k^2 .
- the ratio of their volumes is k^3 .

Length

$$\frac{l_1}{l_2} = \frac{r_1}{r_2} = \frac{h_1}{h_2}$$

Area

$$\frac{A_1}{A_2} = \frac{r_1^2}{r_2^2} = \frac{h_1^2}{h_2^2}$$

Volume

$$\frac{V_1}{V_2} = \frac{r_1^3}{r_2^3} = \frac{h_1^3}{h_2^3}$$

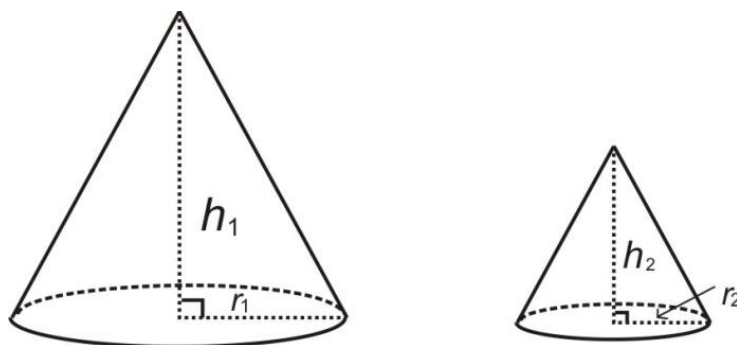

CIRCLE

- The angle subtended by an arc at the centre is twice the angle subtended at the circumference

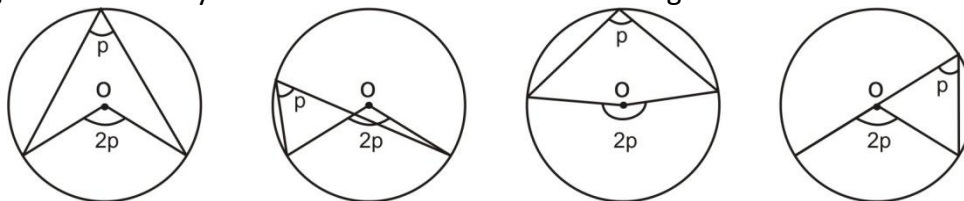

- Angles subtended by an arc in the same segment of a circle are equal.

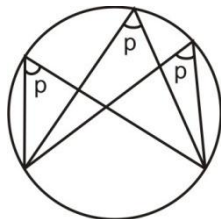

- The angle in a semi-circle is a right angle. [or if a triangle is inscribed in a semi-circle the angle opposite the diameter is a right angle]. $\angle APB = 90^\circ$

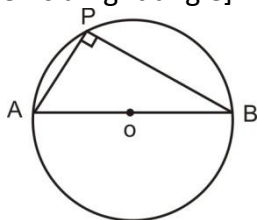

- Opposite angles of a cyclic quadrilateral add up to 180° (supplementary). The corners touch the circle. $A+C = 180^\circ$, $B+D = 180^\circ$

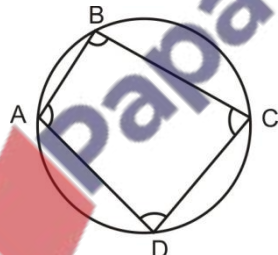

- The exterior angle of a cyclic quadrilateral is equal to the interior opposite angle. ($b = p$)

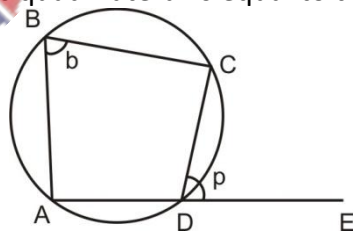

Chord of a circle:

A line joining two points on a circle is called a **chord**.

The area of a circle cut off by a chord is called a **segment**.

AXB is **the minor arc** and AYB is **the major arc**.

- The line from the centre of a circle to the mid-point of a chord bisects the chord at right angles.
- The line from the centre of a circle to the mid-point of a chord bisects the angle subtended by the chord at the centre of the circle.

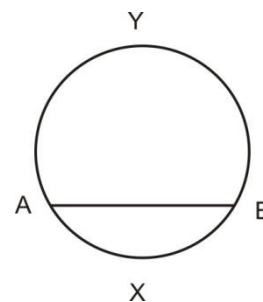

Tangents to a Circle:

- The angle between a tangent and the radius drawn to the point of contact is 90° .

$$ABO = 90^\circ$$

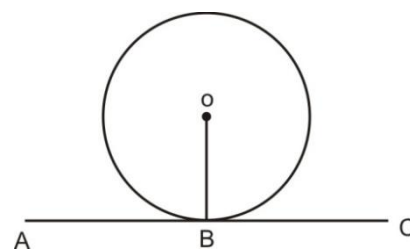

- From any point outside a circle just two tangents to the circle may be drawn and they are of equal length.

$$TA = TB$$

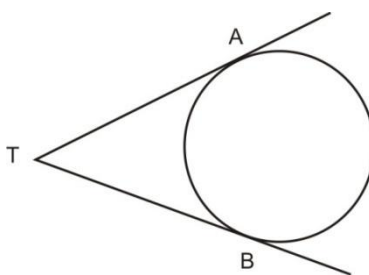

- Alternate Segment Theorem**

The angle between a tangent and a chord through the point of contact is equal to the angle subtended by the chord in the alternate segment.

$$QAB = ACB \quad (p = q)$$

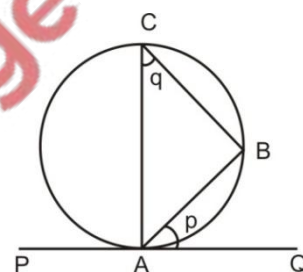

- $TC^2 = AC \times BC$

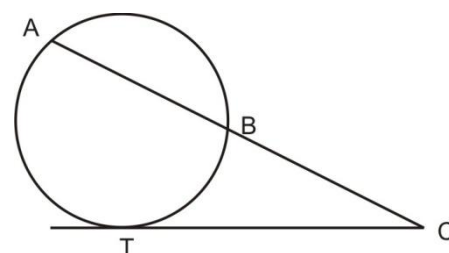

INDICES:

- $a^m \times a^n = a^{m+n}$

- $a^m \div a^n = a^{m-n}$

- $(a^m)^n = a^{mn}$

- $a^0 = 1$

- $a^{-n} = \frac{1}{a^n}$

- $(a \times b)^m = a^m \times b^m$

- $\left(\frac{a}{b}\right)^m = \frac{a^m}{b^m}$

- $(\sqrt[n]{a})^m = a^{m/n}$

- $\sqrt{a} \times \sqrt{b} = \sqrt{a \times b}$

- $\frac{\sqrt{a}}{\sqrt{b}} = \frac{\sqrt{a}}{\sqrt{b}}$

- $(\sqrt{a})^2 = a$

Solving Inequalities:

When we multiply or divide by a negative number the inequality is reversed.

Eg: $4 > -2$

By multiplying by -2 [$4(-2) < (-2)(-2)$]

$-8 < +4$

TRIGONOMETRY

Let ABC be a right angled triangle, where $B = 90^\circ$

- $\sin \theta = \frac{\text{Opposite Side}}{\text{Hypotenuse}} = \frac{O}{H}$

- $\cos \theta = \frac{\text{Adjacent Side}}{\text{Hypotenuse}} = \frac{A}{H}$

- $\tan \theta = \frac{\text{Opposite side}}{\text{Adjacent Side}} = \frac{O}{A}$

SOH CAH TOA

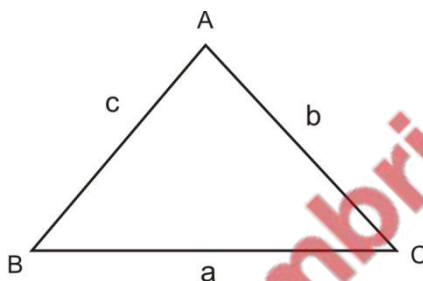
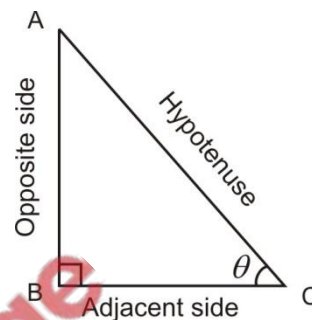

Sine Rule:

$$\frac{a}{\sin A} = \frac{b}{\sin B} = \frac{c}{\sin C}$$

Cosine Rule:

To find the length of a side:

- $a^2 = b^2 + c^2 - 2bc \cos A$
- $b^2 = a^2 + c^2 - 2ac \cos B$
- $c^2 = a^2 + b^2 - 2ab \cos C$

To find an angle when all the three sides are given:

- $\cos A = \frac{b^2 + c^2 - a^2}{2bc}$
- $\cos B = \frac{a^2 + c^2 - b^2}{2ac}$
- $\cos C = \frac{a^2 + b^2 - c^2}{2ab}$



Bearing

The bearing of a point B from another point A is;

(a) an angle measured from the north at A.

(b) In a clockwise direction.

(c) Written as three-figure number (i.e. from 000° to 360°)

Eg: The bearing of B from A is 050° .

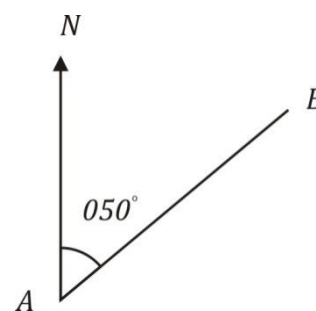

Cartesian co-ordinates

Gradient and equation of a straight line

The gradient of the straight line joining any two given points $A(x_1, y_1)$ and $B(x_2, y_2)$ is;

$$m = \frac{y_2 - y_1}{x_2 - x_1}$$

The gradient/intercept form of the equation of a straight line is $y = mx + c$, where m = gradient and c = intercept on y – axis.

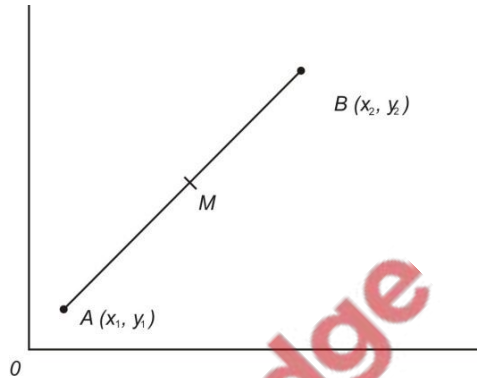
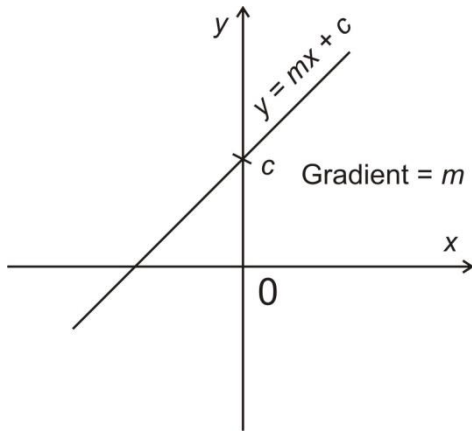

- The midpoint of the line joining two points $A(x_1, y_1)$ and $B(x_2, y_2)$ is; $M = \left(\frac{x_1+x_2}{2}, \frac{y_1+y_2}{2}\right)$
- The distance between two points $A(x_1, y_1)$ and $B(x_2, y_2)$ is; $AB = \sqrt{(x_2 - x_1)^2 + (y_2 - y_1)^2}$
- Parallel lines have the same gradient.
- In a graph, gradient = $\frac{\text{Vertical height}}{\text{Horizontal height}}$ or $\frac{y}{x}$

Distance – Time Graphs:

From O to A : Uniform speed
From B to C : uniform speed
From A to B : Stationery (speed = 0)

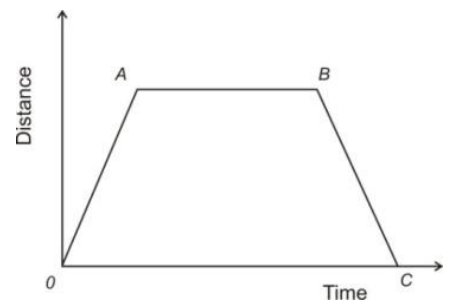

The **gradient** of the graph of a distance-time graph gives the **speed** of the moving body.

Speed – Time Graphs:

From O to A : Uniform speed
From A to B : Constant speed (acceleration = 0)
From B to C : Uniform deceleration / retardation

The **area** under a speed –time graph represents the **distance travelled**.

The **gradient** of the graph is the **acceleration**. If the acceleration is negative, it is called deceleration or retardation. (The moving body is slowing down.)

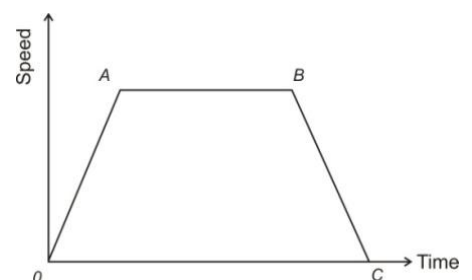

Velocity:

Velocity is the rate of change of distance with respect to the time.

Acceleration:

Acceleration is the rate of change of velocity with respect to time.

SETS:

Notations

- ξ = universal set
- \cup (union) = all the elements
- \cap (intersection) = common elements
- \emptyset or $\{ \}$ = empty set
- \in = belongs to
- \notin = does not belongs to
- \subseteq = Subset
- A' = compliment of A (i.e. the elements of ξ - the elements of A)
- $n(A)$ = the number of elements in A.
- De Morgan's Laws: $(A \cup B)' = (A' \cap B')$
 $(A \cap B)' = (A' \cup B')$

Subset \subseteq

$B \subseteq A$ means every elements of set B is also an element of set A.

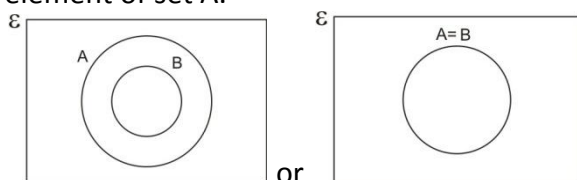

Proper subset \subset

$B \subset A$ means every element of B is an element of set A but $B \neq A$.

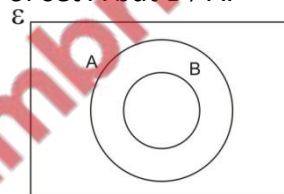

Disjoint sets

Disjoint set do not have any element in common. If A and B are disjoint sets, then

$$A \cap B = \emptyset$$

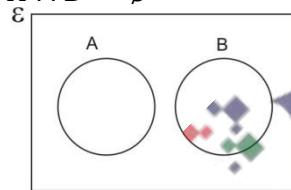

Intersection \cap

$A \cap B$ is the set of elements which are in A and also in B

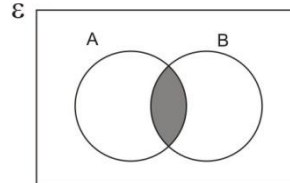

Union \cup

$A \cup B$ is the set of elements in either A, B or both A and B.

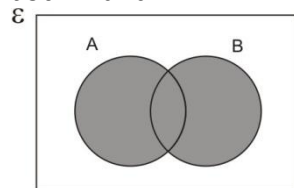

Complement

The complement of A, written as A' refers to the elements in ξ but not in A.

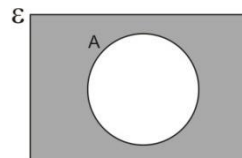

Loci and construction

The locus of a point is a set of points satisfying a given set of conditions.

(a) Locus of points at a distance x from a given point, O .

Locus: The circumference of a circle centre O , radius x .

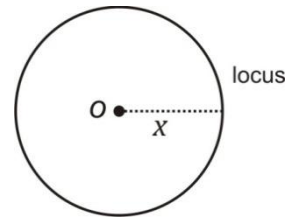

(b) Locus of a points at a distance x from a straight line AB

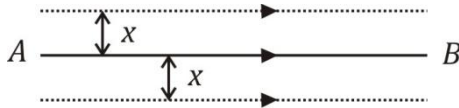

Locus: A pair of parallel lines to the given line AB .

(c) Locus of points equidistance between 2 points.

Locus: Perpendicular bisector of the two points.

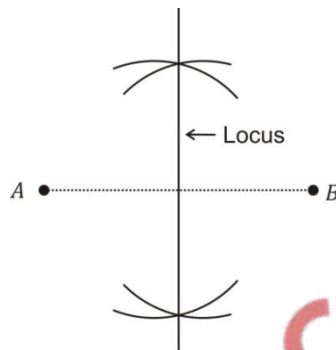

(d) Locus of points equidistant from two given lines AB and AC

Locus: Angle bisector of $\angle BAC$

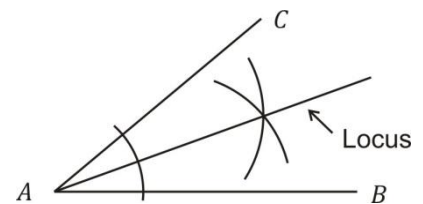

Vectors:

- A vector quantity has both magnitude and direction.
- Vectors a and b represented by the line segments can be added using the parallelogram rule or the nose-to-tail method.

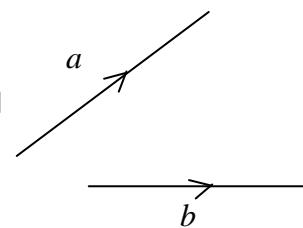

- A scalar quantity has a magnitude but no direction. Ordinary numbers are scalars.
- The negative sign reverses the direction of the vector.
- The result of $a - b$ is $a + -b$
i.e. subtracting b is equivalent to adding the negative of b .

Addition and subtraction of vectors

$$\vec{OA} + \vec{AC} = \vec{OC} \quad (\text{Triangular law of addition})$$

$$\vec{OB} + \vec{OA} = \vec{OC} \quad (\text{parallelogram law of addition})$$

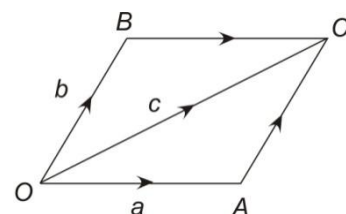

Column Vectors:

The top number is the horizontal component and the bottom number is the vertical component

$$\begin{pmatrix} x \\ y \end{pmatrix}$$

Parallel Vectors:

- Vectors are parallel if they have the same direction. Both components of one vector must be in the same ratio to the corresponding components of the parallel vector.
- In general the vector $k \begin{pmatrix} a \\ b \end{pmatrix}$ is parallel to $\begin{pmatrix} a \\ b \end{pmatrix}$

Modulus of a Vector:

The modulus of a vector a , is written as $|a|$ and represents the length (or magnitude) of the vector.

In general, if $x = \begin{pmatrix} m \\ n \end{pmatrix}$, $|x| = \sqrt{m^2 + n^2}$

MATRICES:**Addition and Subtraction:**

Matrices of the same order are added (or subtracted) by adding (or subtracting) the corresponding elements in each matrix.

$$\begin{pmatrix} a & b \\ c & d \end{pmatrix} + \begin{pmatrix} p & q \\ r & s \end{pmatrix} = \begin{pmatrix} a+p & b+q \\ c+r & d+s \end{pmatrix}$$

$$\begin{pmatrix} a & b \\ c & d \end{pmatrix} - \begin{pmatrix} p & q \\ r & s \end{pmatrix} = \begin{pmatrix} a-p & b-q \\ c-r & d-s \end{pmatrix}$$

Multiplication by a Number:

Each element of a matrix is multiplied by the multiplying number.

$$k \times \begin{pmatrix} a & b \\ c & d \end{pmatrix} = \begin{pmatrix} ka & kb \\ kc & kd \end{pmatrix}$$

Multiplication by another Matrix:

Matrices may be multiplied only if they are compatible. The number of columns in the left-hand matrix must equal the number of rows in the right-hand matrix.

$$\begin{pmatrix} a & b \\ c & d \end{pmatrix} \times \begin{pmatrix} p & q \\ r & s \end{pmatrix} = \begin{pmatrix} ap+br & aq+bs \\ cp+dr & cq+ds \end{pmatrix}$$

- In matrices A^2 means $A \times A$. [you must multiply the matrices together]

The Inverse of a Matrix:

$$\text{If } A = \begin{pmatrix} a & b \\ c & d \end{pmatrix} \text{ then } A^{-1} = \frac{1}{(ad-bc)} \begin{pmatrix} d & -b \\ -c & a \end{pmatrix}$$

- $AA^{-1} = A^{-1}A = I$ where I is the identity matrix.
- The number $(ad - bc)$ is called the **determinant** of the matrix and is written as $|A|$
- If $|A| = 0$, then the **matrix has no inverse**.
- Multiplying by the inverse of a matrix gives the same result as dividing by the matrix.

e.g. if $AB = C$
 $A^{-1}AB = A^{-1}C$
 $B = A^{-1}C$

- If $C = \begin{pmatrix} x \\ y \end{pmatrix}$ and $D = \begin{pmatrix} r \\ s \end{pmatrix}$ then $C + D = \begin{pmatrix} x+r \\ y+s \end{pmatrix}$

Transformations:

a) Reflection:

When describing a reflection, the position of the mirror line is essential.

b) Rotation:

To describe a rotation, the centre of rotation, the angle of rotation and the direction of rotation are required.

A clockwise rotation is negative and an anticlockwise rotation is positive.

>> (angle) (Direction) rotation about (centre)

c) Translation:

When describing a translation it is necessary to give the translation vector

- $+x$ represents movement to the right
- $-x$ represents movement to the left
- $+y$ represents movement to the top
- $-y$ represents movement to the bottom.

>> Translation by the column vector -----

d) Enlargement:

To describe an enlargement, state;

- The scale factor, K
- The centre of enlargement (the invariant point)

$$\text{Scale factor} = \frac{\text{length of the image}}{\text{length of the object}}$$

>> Enlargement by the scale factor --- centre -----

- If $K > 0$, both the object and the image lie on the same side of the centre of enlargement.
- If $K < 0$, the object and the image lie on opposite side of the centre of enlargement.
- If the scale factor lies between 0 and 1, then the resulting image is smaller than the object.

[although the image is smaller than the object, the transformation is still known as an enlargement]

$$\text{Area of image} = K^2 \text{ area of object}$$

Repeated Transformations:

$XT(P)$ means 'perform transformation T on P and then perform X on the image.'

$XX(P)$ may be written $X^2(P)$.

Inverse Transformations:

The inverse of a transformation is the transformation which takes the image back to the object.

If translation T has a vector $\begin{pmatrix} x \\ y \end{pmatrix}$, then the translation which has the opposite effect has vector $\begin{pmatrix} -x \\ -y \end{pmatrix}$.

This is written as T^{-1} .

If rotation R denotes 90° clockwise rotation about (0, 0), then R^{-1} denotes 90° anticlockwise rotation about (0, 0).

For all reflections, the inverse is the same reflection.

Base vectors

The base vectors are considered as $I = \begin{pmatrix} 1 \\ 0 \end{pmatrix}$ and $J = \begin{pmatrix} 0 \\ 1 \end{pmatrix}$

The columns of a matrix give us the images of I and J after the transformation.

Shear:

Shear factor = $\frac{\text{Distance a point moves due to the shear}}{\text{Perpendicular distance of the point from the fixed line}} = \frac{a}{b}$

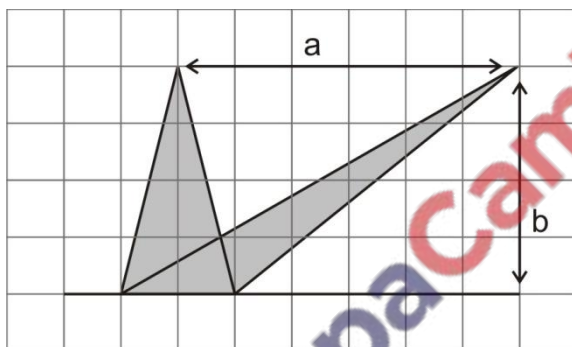

[The shear factor will be the same calculated from any point on the object with the exception of those on the invariant line]

$$\text{Area of image} = \text{Area of object}$$

Stretch:

To describe a stretch, state;

- the stretch factor, p
- the invariant line,
- the direction of the stretch

(always perpendicular to the invariant line)

$$\text{Scale factor} = \frac{\text{Perpendicular distance of } C' \text{ from } AB}{\text{Perpendicular distance of } C \text{ from } AB}$$

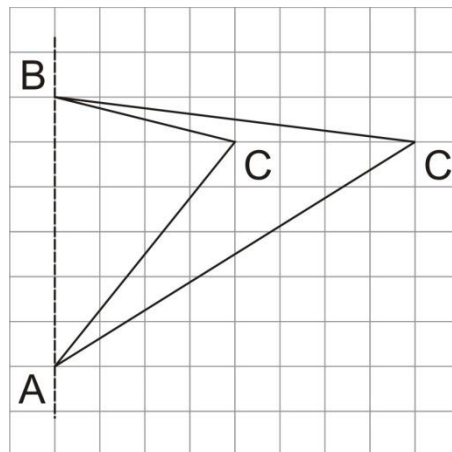

Where, P is the stretch factor

$$\text{Area of image} = p \times \text{Area of object}$$

Transformation by Matrices

Reflection

Matrix	Transformation
$\begin{pmatrix} 1 & 0 \\ 0 & -1 \end{pmatrix}$	Reflection in the x-axis
$\begin{pmatrix} -1 & 0 \\ 0 & 1 \end{pmatrix}$	Reflection in the y-axis
$\begin{pmatrix} 0 & 1 \\ 1 & 0 \end{pmatrix}$	Reflection in the line $y = x$
$\begin{pmatrix} 0 & -1 \\ -1 & 0 \end{pmatrix}$	Reflection in the line $y = -x$

Rotation

Matrix	Angle	Direction	centre
$\begin{pmatrix} 0 & -1 \\ 1 & 0 \end{pmatrix}$	90°	anticlockwise	(0, 0)
$\begin{pmatrix} 0 & 1 \\ -1 & 0 \end{pmatrix}$	90°	clockwise	(0, 0)
$\begin{pmatrix} -1 & 0 \\ 0 & -1 \end{pmatrix}$	180°	Clockwise/ anticlockwise	(0, 0)

Enlargement

$\begin{pmatrix} k & 0 \\ 0 & k \end{pmatrix}$ where $k =$ scale factor and centre of enlargement = (0, 0)

Stretch

Matrix	Stretch factor	Invariant line	Direction
$\begin{pmatrix} k & 0 \\ 0 & 1 \end{pmatrix}$	k	y-axis	Parallel to x - axis
$\begin{pmatrix} 1 & 0 \\ 0 & k \end{pmatrix}$	k	x - axis	Parallel to y - axis

Shear

Matrix	Shear factor	Invariant line	Direction
$\begin{pmatrix} 1 & k \\ 0 & 1 \end{pmatrix}$	k	x-axis	Parallel to x - axis
$\begin{pmatrix} 1 & 0 \\ k & 1 \end{pmatrix}$	k	y - axis	Parallel to y - axis

STATISTICS

Bar Graph:

A bar chart makes numerical information easy to see by showing it in a pictorial form.

The width of the bar has no significance. The length of each bar represents the quantity.

Pie Diagram:

The information is displayed using sectors of a circle.

Histograms:

A histogram displays the frequency of either continuous or grouped discrete data in the form of bars.

The bars are joined together.

The bars can be of varying width.

The frequency of the data is represented by the area of the bar and not the height.

[When class intervals are different it is the area of the bar which represents the frequency not the height]. Instead of frequency being plotted on the vertical axis, frequency density is plotted.

$$\text{Frequency density} = \frac{\text{frequency}}{\text{class width}}$$

Mean:

The mean of a series of numbers is obtained by adding the numbers and dividing the result by the number of numbers.

$$\text{Mean} = \frac{\sum fx}{\sum f} \quad \text{where } \sum fx \text{ means 'the sum of the products'}$$

i.e. $\sum (\text{number} \times \text{frequency})$

and $\sum f$ means 'the sum of the frequencies'.

Median:

The median of a series of numbers is obtained by arranging the numbers in ascending order and then choosing the number in the 'middle'. If there are two 'middle' numbers the median is the average (mean) of these two numbers.

Mode:

The mode of a series of numbers is simply the number which occurs most often.

Frequency tables:

A frequency table shows a number x such as a score or a mark, against the frequency f or number of times that x occurs.

Cumulative frequency:

Cumulative frequency is the total frequency up to a given point.

Cumulative frequency Curve:

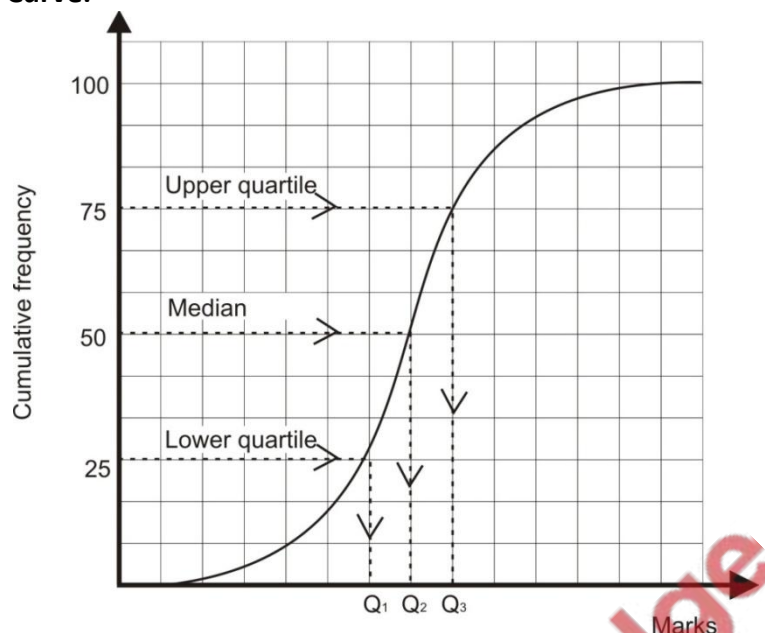

A cumulative frequency curve shows the median at the 50th percentile of the cumulative frequency. The value at the 25th percentile is known as the lower quartile and that at the 75th percentile as the upper quartile.

A measure of the spread or dispersion of the data is given by the inter-quartile range where **inter-quartile range = upper quartile – lower quartile.**

Probability:

- Probability is the study of chance, or the likelihood of an event happening.
- Probability of an event = $\frac{\text{number of favourable outcomes}}{\text{Total number of equally likely outcomes}}$
- If the probability = 0 it implies the event is impossible
- If the probability = 1 it implies the event is certain to happen.
- All probabilities lie between 0 and 1.
- Probabilities are written using fractions or decimals.

Exclusive events:

Two events are exclusive if they cannot occur at the same time.

The OR Rule:

For exclusive events A and B

$$p(A \text{ or } B) = p(A) + p(B)$$

Independent events:

Two events are independent if the occurrence of one even is unaffected by the occurrence of the other.

The AND Rule:

$$p(A \text{ and } B) = p(A) \times p(B)$$

where $p(A)$ = probability of A occurring

$p(B)$ = probability of B occurring

Tree diagrams:

A tree diagram is a diagram used to represent probabilities when two or more events are combined.

Symmetry:

- A line of symmetry divides a two-dimensional shape into two congruent (identical) shapes.
- A plane of symmetry divides a three-dimensional shape into two congruent solid shapes.
- A two-dimensional shape has rotational symmetry if, when rotated about a central point, it fits its outline. The number of times it fits its outline during a complete revolution is called the order of rotational symmetry.

Shape	Number of Lines of Symmetry	Order of Rotational Symmetry
Square	4	4
Rectangle	2	2
Parallelogram	0	2
Rhombus	2	2
Trapezium	0	1
Kite	1	1
Equilateral Triangle	3	3
Regular Hexagon	6	6

