



Cambridge IGCSE™

CANDIDATE
NAME

CENTRE
NUMBER

--	--	--	--	--

CANDIDATE
NUMBER

--	--	--	--

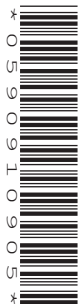

CO-ORDINATED SCIENCES

0654/41

Paper 4 Theory (Extended)

October/November 2024

2 hours

You must answer on the question paper.

No additional materials are needed.

INSTRUCTIONS

- Answer **all** questions.
- Use a black or dark blue pen. You may use an HB pencil for any diagrams or graphs.
- Write your name, centre number and candidate number in the boxes at the top of the page.
- Write your answer to each question in the space provided.
- Do **not** use an erasable pen or correction fluid.
- Do **not** write on any bar codes.
- You may use a calculator.
- You should show all your working and use appropriate units.

INFORMATION

- The total mark for this paper is 120.
- The number of marks for each question or part question is shown in brackets [].
- The Periodic Table is printed in the question paper.

This document has **24** pages. Any blank pages are indicated.

1 Fig. 1.1 is a diagram of the alimentary canal and associated organs in humans.

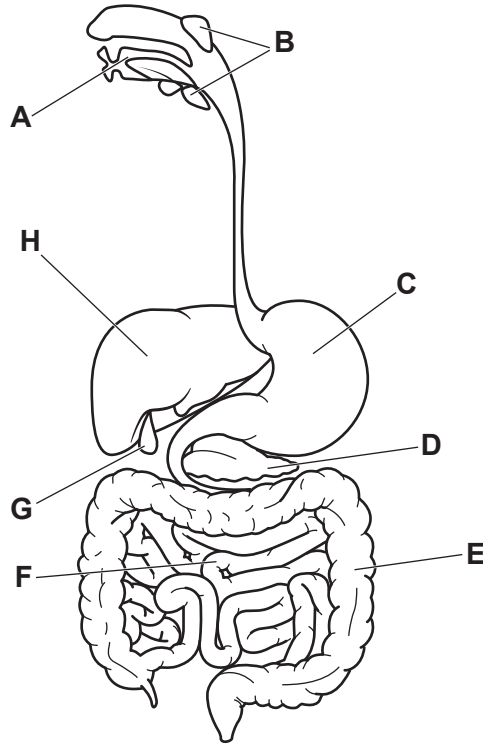

Fig. 1.1

(a) State the letter that identifies a part in Fig. 1.1:

- that contains villi
- that produces bile
- that produces insulin
- where mechanical digestion occurs.

[4]

(b) Identify the name of the enzyme secreted by part **B** in Fig. 1.1 **and** describe its function.

name

function

.....

.....

[3]

(c) Teeth are involved in the process of digestion.

State the names of **two** different types of teeth.

1

2

[2]

(d) Outline the different roles of bile in digestion.

.....
.....
.....
.....
.....
.....
.....
.....
.....
.....
.....

[4]

[Total: 13]

2 The arrangement and movement of particles in solids, liquids and gases are different.

(a) Draw **one** line from each state of matter to the arrangement and movement of particles.

state of matter

**arrangement and movement
of particles**

solid

particles are close together but
arranged randomly and free to
move around each other

liquid

particles are far apart in a random
arrangement and move quickly in
all directions

gas

particles are close together and
vibrate about fixed positions in a
regular lattice

[2]

(b) A student tests the melting point of four different solids.

Table 2.1 shows their results.

Table 2.1

solid	A	B	C	D
melting point/°C	72	81–88	104	61

State which of the four solids, **A**, **B**, **C** or **D**, is a mixture. Explain your answer.

mixture

explanation

.....

[2]

(c) Table 2.2 shows the relative molecular mass, M_r , of three different gases.

Table 2.2

gas	carbon dioxide CO_2	ammonia NH_3	sulfur dioxide SO_2
M_r	44	17	64

State which gas will diffuse **fastest**. Explain your answer.

gas

explanation

..... [2]

(d) Sulfur dioxide is a common pollutant in the air.

(i) State the source of sulfur dioxide in the air.

..... [1]

(ii) State an adverse effect of sulfur dioxide in the air.

..... [1]

(e) Sulfur is used in the manufacture of sulfuric acid in the Contact Process.

Complete and balance the equations for the Contact Process.

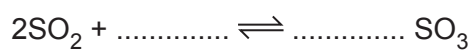
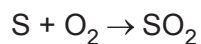

[4]

[Total: 12]

3 A student investigates the properties of graphite.

(a) Fig. 3.1 shows a cylinder of graphite.

The cylinder is 6.50 cm long and has a cross-sectional area of 0.300 cm².

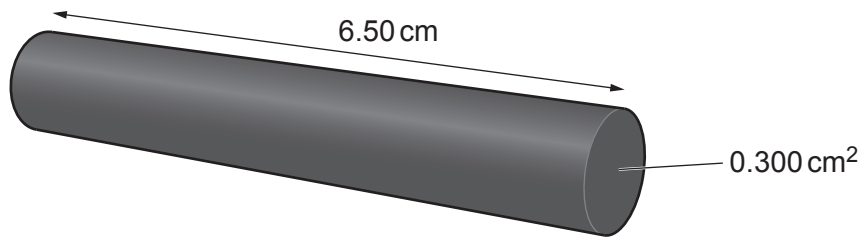

Fig. 3.1

(i) Show that the volume of the cylinder of graphite is 1.95 cm³.

[1]

(ii) The mass of the cylinder of graphite is 4.40 g.

Calculate the density of graphite.

density = g/cm³ [2]

- (b) The student investigates the resistance of the cylinder of graphite using the circuit shown in Fig. 3.2.

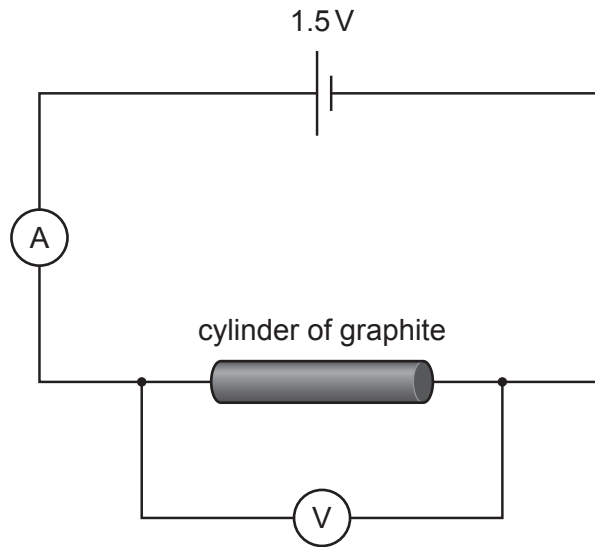

Fig. 3.2

- (i) State the reading shown on the voltmeter in Fig. 3.2.

reading = V [1]

- (ii) The ammeter reads 0.60A.

Use your answer to (b)(i) to calculate the resistance of the cylinder of graphite.

resistance = Ω [2]

- (iii) A different cylinder of graphite has double the length and double the cross-sectional area of the cylinder in Fig. 3.2.

Explain why the resistance of both cylinders is the same.

.....

 [2]

- (c) Graphite is a solid at room temperature.

Describe the main method of thermal energy transfer in solids.

.....

 [2]

- 4 (a) A student monitors their heart rate during vigorous exercise for 30 minutes.

Their heart rate is measured in beats per minute (bpm).

Fig. 4.1 is a graph of the results.

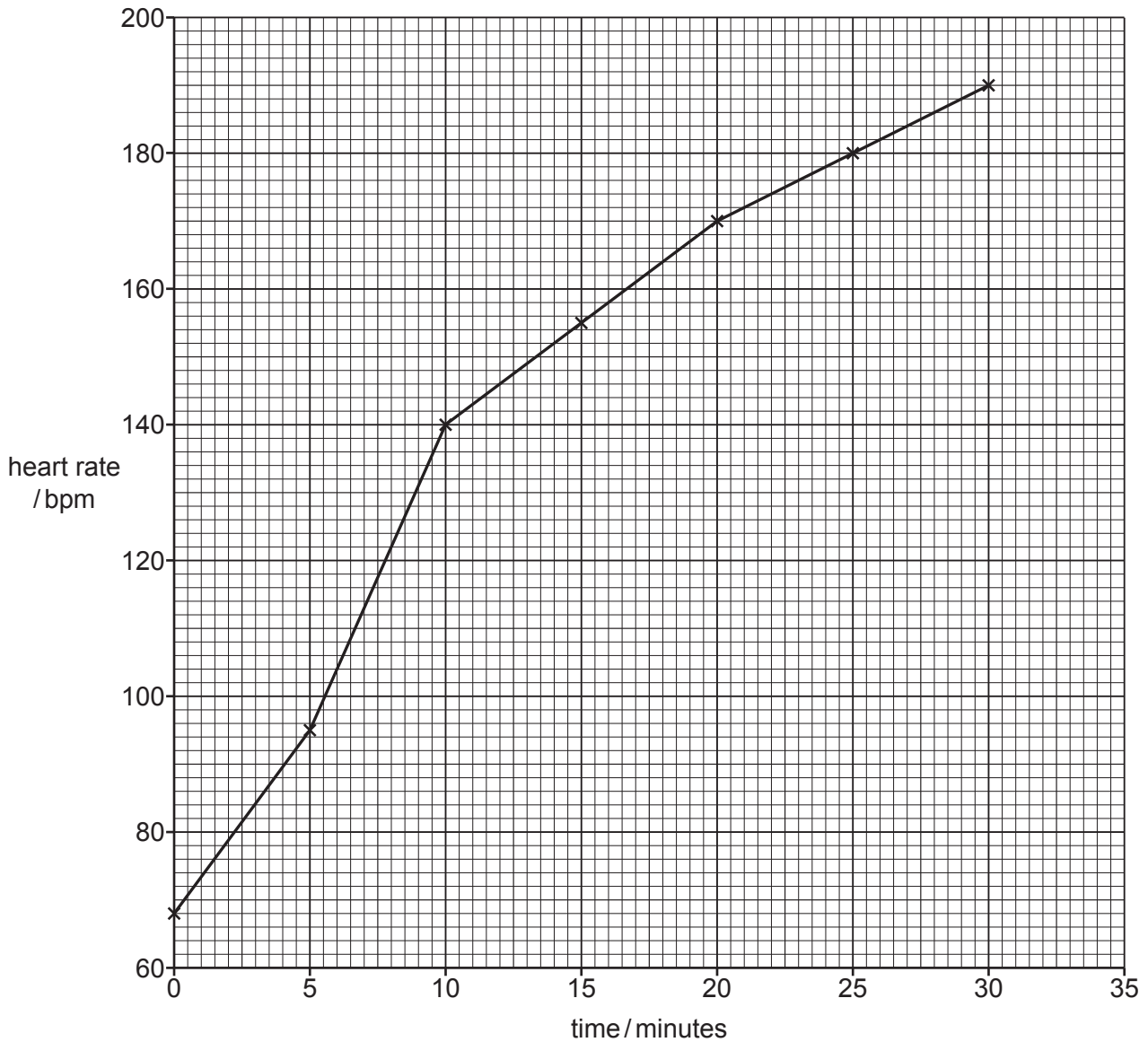

Fig. 4.1

Complete the sentences to describe **and** explain the results in Fig. 4.1.

During exercise, the heart rate increases to a maximum of bpm.

Heart rate increases because the body requires more energy for muscular

Energy is released by the process of aerobic respiration.

The oxygen required for aerobic respiration is transported by in red blood cells.

[3]

(b) Complete the balanced chemical equation for aerobic respiration.

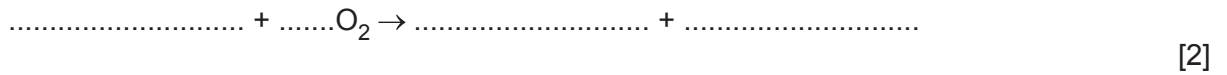

(c) During vigorous exercise energy is also released by anaerobic respiration.

Describe **two** disadvantages of anaerobic respiration.

- 1
-
- 2
- [2]

(d) Blood is transported by blood vessels.

(i) Explain why veins in the legs have valves but arteries in the legs do not have valves.

.....
.....
.....
.....
..... [2]

(ii) State the name of the main artery that transports blood away from the heart.

..... [1]

(e) Plants have specialised transport vessels.

State the name of **two** plant vessels specialised for transport.

- 1
 - 2
- [2]

[Total: 12]

- 5 (a) Complete the sentences about the structure of an atom.

An atom has a central nucleus containing and
and a series of of electrons surrounding the nucleus.

[2]

- (b) The element oxygen exists as isotopes.

State what is meant by isotopes.

.....
.....
.....
..... [3]

- (c) Oxygen atoms join together with covalent bonds to form oxygen molecules, O_2 .

Complete the dot-and-cross diagram to show the bonding in an oxygen molecule.

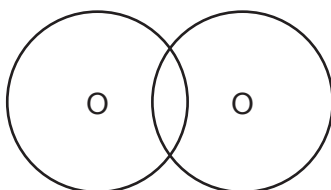

[2]

- (d) Oxygen atoms bond with silicon atoms to form silicon(IV) oxide, SiO_2 , which has a high melting point and is hard like diamond.

Describe the way the silicon and oxygen bond in the structure of silicon(IV) oxide.

.....
.....
..... [2]

[Total: 9]

6 Fig. 6.1 shows a mobile phone (cell phone) on a wireless charging pad.

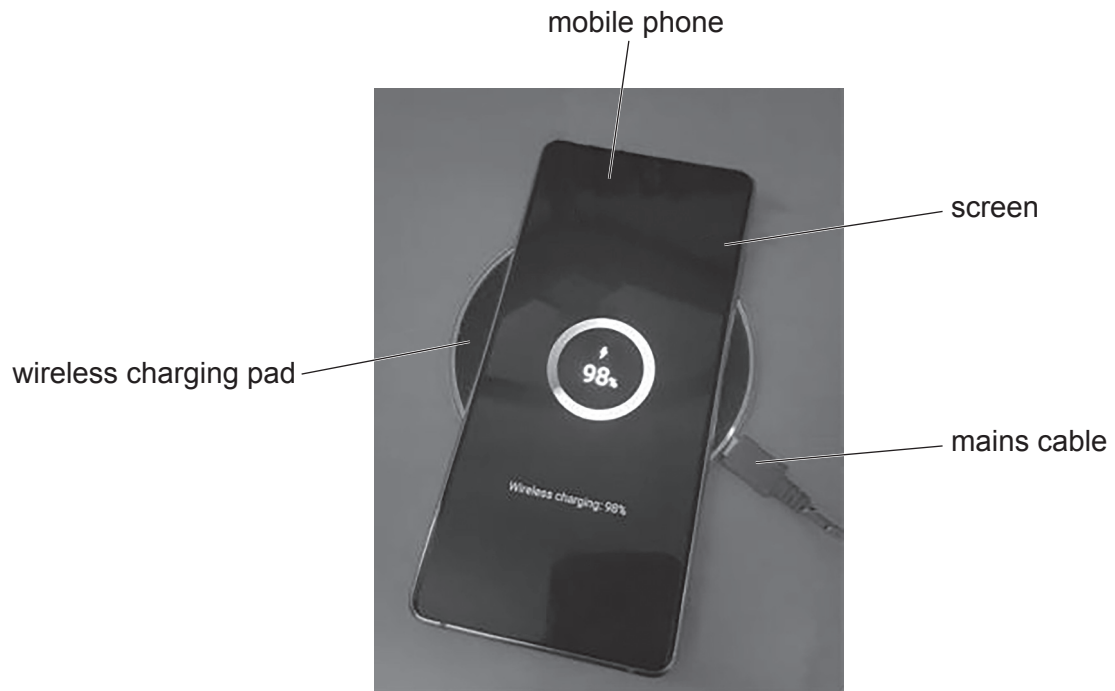

Fig. 6.1

(a) The screen of the mobile phone is made from glass.

When light travels from air into glass it is refracted and changes direction.

(i) Place **one** tick (✓) in each row of Table 6.1 to state the effect on the properties of frequency, speed and wavelength for light as the light travels from air into glass.

Table 6.1

	decreases	stays the same	increases
frequency			
speed			
wavelength			

[3]

(ii) A ray of light is incident on the screen of the mobile phone.

The angle of incidence is 53° .

The refractive index of glass is 1.5.

Calculate the angle of refraction r .

$r = \dots\dots\dots^\circ$ [2]

(b) The mobile phone battery holds a maximum charge of 3300 C.

The current used to charge the battery is 0.60 A.

Calculate the time taken to fully charge the mobile phone battery.

time taken = $\dots\dots\dots$ s [2]

(c) The wireless charging pad in Fig. 6.1 contains a coil of wire. The mains cable provides an alternating current (a.c.) to the coil of wire.

The mobile phone contains a second coil of wire.

Describe how an electromotive force (e.m.f.) is induced in the second coil of wire when the mobile phone is placed on the charging pad.

.....
.....
.....
..... [2]

[Total: 9]

- 7 (a) A student cuts cylinders of potato of almost identical size and measures the length of each one.

The student immerses each potato cylinder in a different concentration of sucrose solution for 24 hours.

After 24 hours, the student measures the lengths of each potato cylinder.

The student calculates the percentage change in length of the potato cylinders.

Table 7.1 shows the results.

Table 7.1

concentration of sucrose solution in mol/dm ³	length of potato cylinder before immersion /mm	length of potato cylinder after immersion /mm	change in length of potato cylinder /mm	percentage change in length of potato cylinder
0.20	50.0	51.5	1.5	+3.0
0.40	50.0	51.0	1.0	
0.60	49.0	49.5	0.5	+1.0
0.80	49.5	48.0	-1.5	-3.0
1.00	49.5	47.5	-2.0	-4.0

- (i) Calculate the percentage change in the length of the potato cylinder in the 0.40 mol/dm³ sucrose solution.

percentage change =% [2]

- (ii) Identify the concentration of sucrose solution in Table 7.1 that results in the smallest water potential gradient.

concentration = mol/dm³ [1]

- (iii) Identify the concentration of sucrose solution in Table 7.1 that results in the potato cells with the greatest turgor pressure.

concentration = mol/dm³ [1]

- (iv) State the name of the process that causes the change in length in potato cylinders.

..... [1]

(b) Potato plants can reproduce asexually.

(i) State the type of cell division used for asexual reproduction.

..... [1]

(ii) Explain why a population of plants produced by asexual reproduction is unlikely to survive changes in the environment.

.....
.....
.....
.....
..... [2]

(iii) State **two** raw materials required for the growth of the potato plant.

1
2 [2]

[Total: 10]

8 A student investigates the reaction between zinc and dilute nitric acid, HNO_3 .

Zinc nitrate, $\text{Zn}(\text{NO}_3)_2$, and hydrogen gas, H_2 , are made.

(a) Construct the balanced symbol equation for this reaction.

..... [2]

(b) The student performs two reactions, X and Y, using different concentrations of nitric acid.

They use the same mass of zinc granules and the same temperature of nitric acid in each reaction.

Fig. 8.1 shows a graph of their results.

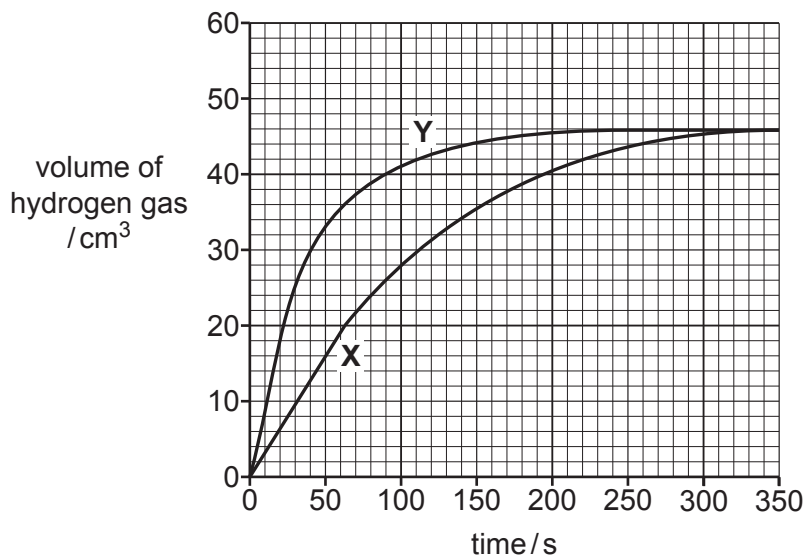

Fig. 8.1

(i) State which reaction, X or Y, uses a higher concentration of nitric acid.

Use Fig. 8.1 to explain your answer.

reaction

explanation

.....

.....

[1]

(ii) Determine the average rate of reaction **X** during the first 50 seconds.

average rate = cm^3/s [2]

(c) Reactions **X** and **Y** both produced 46 cm^3 of hydrogen gas measured at room temperature and pressure (r.t.p.).

Calculate the mass of 46 cm^3 of hydrogen gas.

The volume of one mole of any gas is 24 dm^3 at room temperature and pressure (r.t.p.).

Show your working.

[M_r : H_2 , 2]

mass of 46 cm^3 of hydrogen gas = g [3]

(d) The student repeats reaction **Y** at a **higher temperature**.

State and explain how the rate of reaction changes.

Use ideas about collisions between particles.

.....

.....

.....

..... [3]

[Total: 11]

9 Tritium (${}^3_1\text{H}$) is an isotope of hydrogen.

(a) Tritium decays by beta (β) emission.

(i) Use correct nuclide notation to complete the decay equation for tritium.



[3]

(ii) The half-life of tritium is 12.3 years.

Calculate the time taken, in years, for 87.5% of a sample of tritium to decay.

time = years [2]

(b) A beta particle is emitted from a tritium nucleus with a speed of $2.0 \times 10^8 \text{ m/s}$ and a kinetic energy of $1.8 \times 10^{-14} \text{ J}$.

(i) Calculate the distance travelled by the beta particle in $3.5 \times 10^{-10} \text{ s}$.

distance = m [2]

(ii) Calculate the mass of the beta particle.

mass = kg [2]

[Total: 9]

10 Scientists investigate eutrophication in a lake.

They measure the relative abundance of different factors.

Fig. 10.1 is a graph summarising the results.

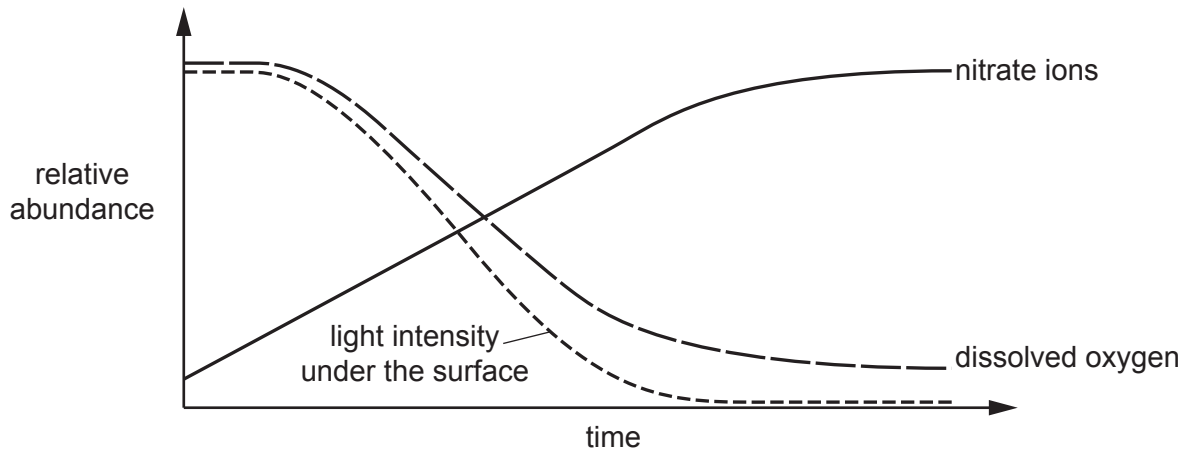

Fig. 10.1

(a) The growth of surface producers in the lake increases during eutrophication.

Explain why, using the information in Fig. 10.1.

.....

.....

.....

.....

.....

..... [2]

(b) The number of underwater producers in the lake decreases during eutrophication.

Explain why, using the information in Fig. 10.1.

.....

.....

.....

.....

..... [2]

(c) State the name of the type of organisms that cause the change in dissolved oxygen in the lake in Fig. 10.1.

..... [1]

[Total: 5]

- 11 Aluminium is extracted by electrolysis from the ore bauxite that contains aluminium oxide, Al_2O_3 .

The equation for the overall reaction is



- (a) A scientist electrolyses 81.6 g of aluminium oxide.

Calculate the maximum mass of aluminium extracted from the aluminium oxide.

Show your working.

[A_r : Al, 27; O, 16]

mass of aluminium = g [2]

- (b) At the anode oxide ions, O^{2-} , form oxygen molecules.

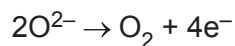

State if this reaction is oxidation or reduction.

Explain your answer.

.....
 [1]

- (c) Construct the ionic half-equation for the reaction at the cathode.

..... [2]

- (d) Iron can be extracted from iron oxide by heating the iron oxide with carbon.

Explain why aluminium **cannot** be extracted from aluminium oxide using this method.

.....
 [1]

(e) Fig. 11.1 shows metallic bonding.

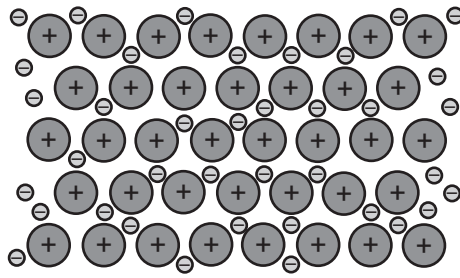

Fig. 11.1

Use Fig. 11.1 to explain why metals conduct electricity.

.....

.....

..... [2]

[Total: 8]

12 A car is moving at 9.0 m/s along a flat horizontal road.

The driver applies the brakes, and the car slows down and stops.

(a) Fig. 12.1 shows a speed–time graph for the car as it brakes.

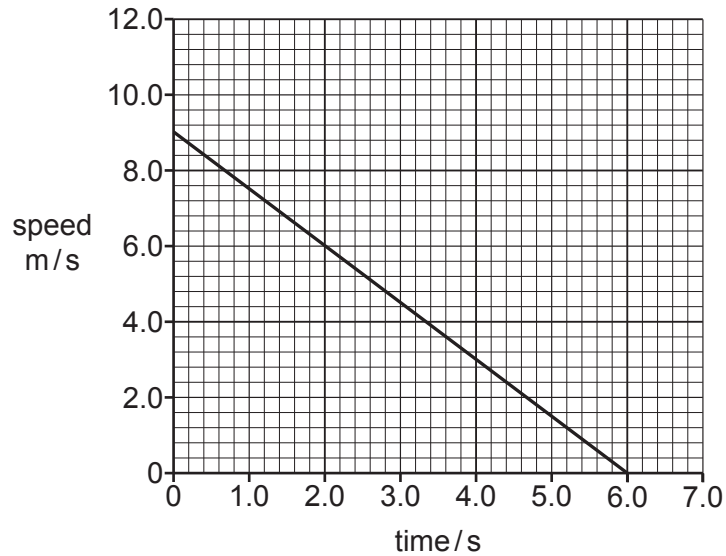

Fig. 12.1

(i) Complete the sentence to describe one energy transfer that takes place.

The kinetic energy of the car is transferred to energy of the surroundings.

[1]

(ii) The braking force acting on the car is 2500 N.

Calculate the work done by the braking force in stopping the car.

work done = J [3]

(b) Fig. 12.2 shows the driver pushing the brake pedal with his foot.

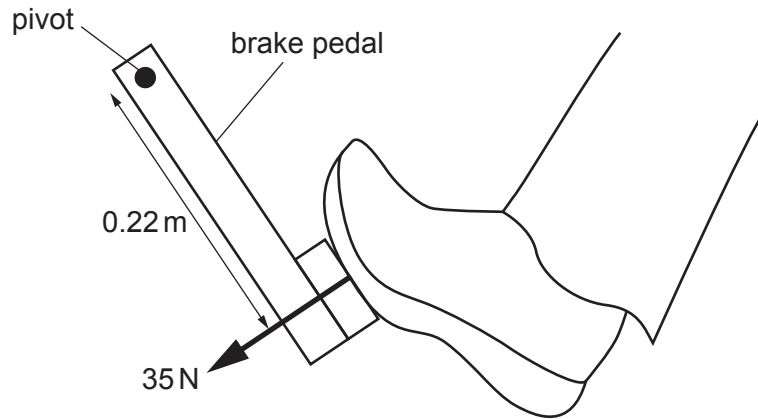

Fig. 12.2

The driver applies a force of 35 N on the brake pedal.

The force is applied 0.22 m from the pivot.

Calculate the moment of the force about the pivot.

moment = Nm [2]

(c) When the brakes are applied, a lamp switches on to alert other drivers.

(i) The lamp uses a current of 3.0 A and has a power output of 36 W.

Calculate the potential difference across the lamp.

potential difference = V [2]

(ii) The lamp emits light with a wavelength of 7.5×10^{-7} m.

Calculate the frequency of the light emitted by the lamp.

State the unit for your answer.

frequency = unit [4]

[Total: 12]

The Periodic Table of Elements

Group																	
I	II	III										IV	V	VI	VII	VIII	
3 Li lithium 7	4 Be beryllium 9	1 H hydrogen 1										6 C carbon 12	7 N nitrogen 14	8 O oxygen 16	9 F fluorine 19	2 He helium 4	
11 Na sodium 23	12 Mg magnesium 24	Key atomic number atomic symbol name relative atomic mass										14 Si silicon 28	15 P phosphorus 31	16 S sulfur 32	17 Cl chlorine 35.5	18 Ar argon 40	
19 K potassium 39	20 Ca calcium 40	21 Sc scandium 45	22 Ti titanium 48	23 V vanadium 51	24 Cr chromium 52	25 Mn manganese 55	26 Fe iron 56	27 Co cobalt 59	28 Ni nickel 59	29 Cu copper 64	30 Zn zinc 65	31 Ga gallium 70	32 Ge germanium 73	33 As arsenic 75	34 Se selenium 79	35 Br bromine 80	36 Kr krypton 84
37 Rb rubidium 85	38 Sr strontium 88	39 Y yttrium 89	40 Zr zirconium 91	41 Nb niobium 93	42 Mo molybdenum 96	43 Tc technetium —	44 Ru ruthenium 101	45 Rh rhodium 103	46 Pd palladium 106	47 Ag silver 108	48 Cd cadmium 112	49 In indium 115	50 Sn tin 119	51 Sb antimony 122	52 Te tellurium 128	53 I iodine 127	54 Xe xenon 131
55 Cs caesium 133	56 Ba barium 137	57–71 lanthanoids	72 Hf hafnium 178	73 Ta tantalum 181	74 W tungsten 184	75 Re rhenium 186	76 Os osmium 190	77 Ir iridium 192	78 Pt platinum 195	79 Au gold 197	80 Hg mercury 201	81 Tl thallium 204	82 Pb lead 207	83 Bi bismuth 209	84 Po polonium —	85 At astatine —	86 Rn radon —
87 Fr francium —	88 Ra radium —	89–103 actinoids	104 Rf rutherfordium —	105 Db dubnium —	106 Sg seaborgium —	107 Bh bohrium —	108 Hs hassium —	109 Mt meitnerium —	110 Ds darmstadtium —	111 Rg roentgenium —	112 Cn copernicium —	113 Nh nihonium —	114 Fl flerovium —	115 Mc moscovium —	116 Lv livermorium —	117 Ts tennessine —	118 Og oganesson —

lanthanoids	57 La lanthanum 139	58 Ce cerium 140	59 Pr praseodymium 141	60 Nd neodymium 144	61 Pm promethium —	62 Sm samarium 150	63 Eu europium 152	64 Gd gadolinium 157	65 Tb terbium 159	66 Dy dysprosium 163	67 Ho holmium 165	68 Er erbium 167	69 Tm thulium 169	70 Yb ytterbium 173	71 Lu lutetium 175
actinoids	89 Ac actinium —	90 Th thorium 232	91 Pa protactinium 231	92 U uranium 238	93 Np neptunium —	94 Pu plutonium —	95 Am americium —	96 Cm curium —	97 Bk berkelium —	98 Cf californium —	99 Es einsteinium —	100 Fm fermium —	101 Md mendelevium —	102 No nobelium —	103 Lr lawrencium —

The volume of one mole of any gas is 24 dm³ at room temperature and pressure (r.t.p.).