



Chemical Bonding

0 Levels (GCE & iGCSE)

(IGCSE 0620 - MCQs)0620_w/14/qp13

8 Which substance is methane?

	volatility	electrical conductivity at room temperature	solubility in water
A	high	good	soluble
B	high	poor	insoluble
C	low	good	soluble
D	low	poor	insoluble

7 Element X, ${}_{9}^{19}\text{X}$, forms a compound with element Y, ${}_{19}^{39}\text{Y}$.

Which statement describes the bonding in the compound formed?

- A X and Y share electrons.
- B X gives away one electron to Y.
- C Y gives away one electron to X.
- D Y gives away two electrons to X.

0620_w/14/qp13

6 Slate has a layered structure and can easily be split into thin sheets.

Which diagram shows a structure most like that of slate?

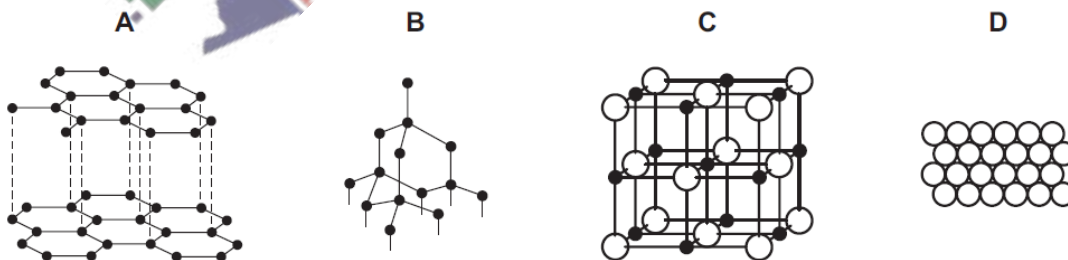

0620_w/14/qp11

7 Sodium chloride is an ionic solid.

Which statement is **not** correct?

- A Ions are formed when atoms lose or gain electrons.
- B Ions in sodium chloride are strongly held together.
- C Ions with the same charge attract each other.
- D Sodium chloride solution can conduct electricity.

0620_w/14/qp11

8 Caesium chloride and rubidium bromide are halide compounds of Group I elements.

Caesium chloride has the formula1....., a relative formula mass2..... that of rubidium bromide and bonds that are3..... .

Which words correctly complete gaps 1, 2 and 3?

	1	2	3
A	CaCl	different from	ionic
B	CaCl	the same as	covalent
C	CsCl	different from	ionic
D	CsCl	the same as	covalent

0620_w/14/qp11

7 The electronic structures of atoms P and Q are shown.

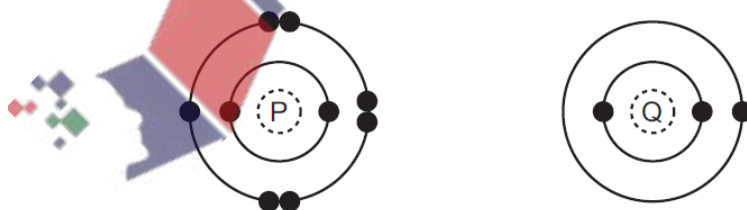

P and Q react to form an ionic compound.

What is the formula of the compound?

- A Q_7P
- B QP
- C QP_3
- D QP_7

0620_w/13/qp13

6 Which statement about the bonding in a molecule of water is **not** correct?

- A Both hydrogen and oxygen have a noble gas configuration of electrons.
- B Each hydrogen shares its one electron with oxygen.
- C Oxygen shares one of its own electrons with each hydrogen.
- D Oxygen shares two of its own electrons with each hydrogen.

0620_w/13/qp13

7 The diagrams show the electron arrangements in the atoms of four elements.

Which element does **not** form a covalent bond?

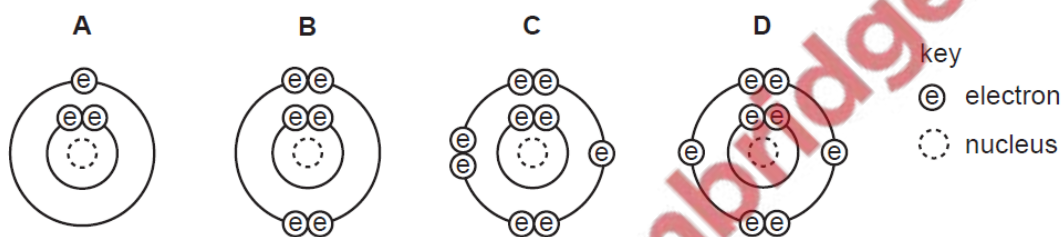

0620_w/13/qp11

6 Rubidium is in Group I of the Periodic Table and bromine is in Group VII.

Rubidium reacts with bromine to form an ionic compound.

Which row shows the electron change taking place for rubidium and the correct formula of the rubidium ion?

	electron change	formula of ion formed
A	electron gained	Rb^+
B	electron gained	Rb^-
C	electron lost	Rb^+
D	electron lost	Rb^-

0620_w/13/qp11

20 The diagram shows an outline of the Periodic Table.

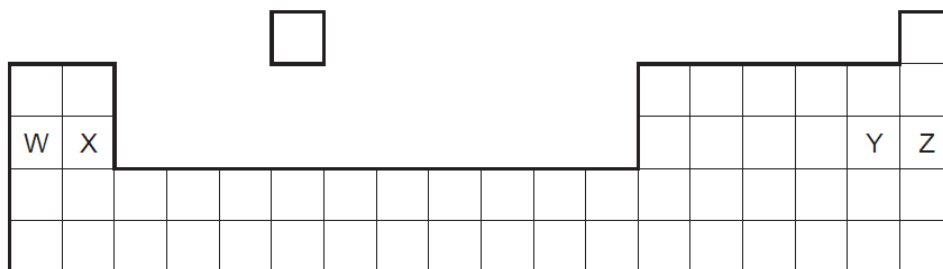

Which ionic compound could be formed?

- A** W^+Y^- **B** W^+Z^- **C** X^+Y^- **D** X^+Z^-

0620_w/12/qp13

20 The diagram shows an outline of the Periodic Table.

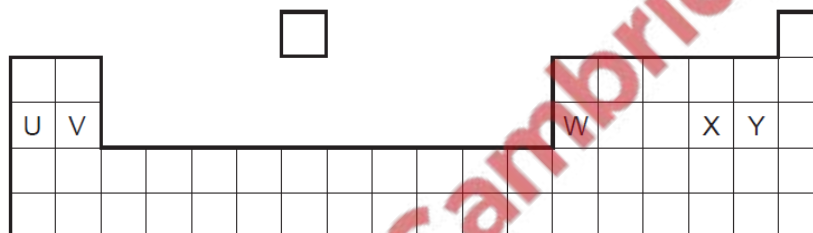

Which of the elements U, V, W, X and Y would react together in the ratio of 1 : 1?

- A** U and X **B** U and Y **C** V and Y **D** W and X

0620_w/12/qp11

7 The table shows the electronic structures of four atoms.

atom	electronic structure
W	2,1
X	2,7
Y	2,8,4
Z	2,8,8

Which two atoms combine to form an ionic compound?

- A** W and X **B** W and Y **C** X and Y **D** X and Z

0620_w/12/qp11

6 In the molecules CH_4 , HCl and H_2O , which atoms use **all** of their outer shell electrons in bonding?

- A C and Cl B C and H C Cl and H D H and O

0620_w/12/qp11

6 Two elements, represented by \bigcirc and \bullet , form a compound.

Which diagram shows molecules of the compound?

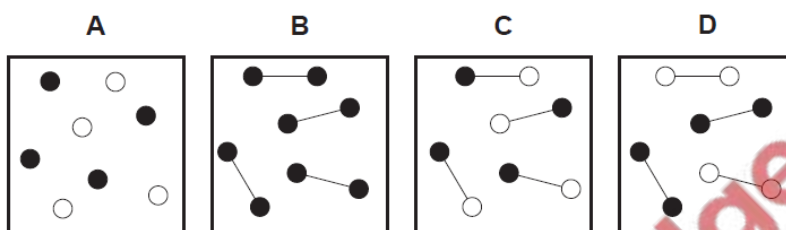

0620_w/11/qp11

4 The diagram shows the electronic structures of atoms P and Q.

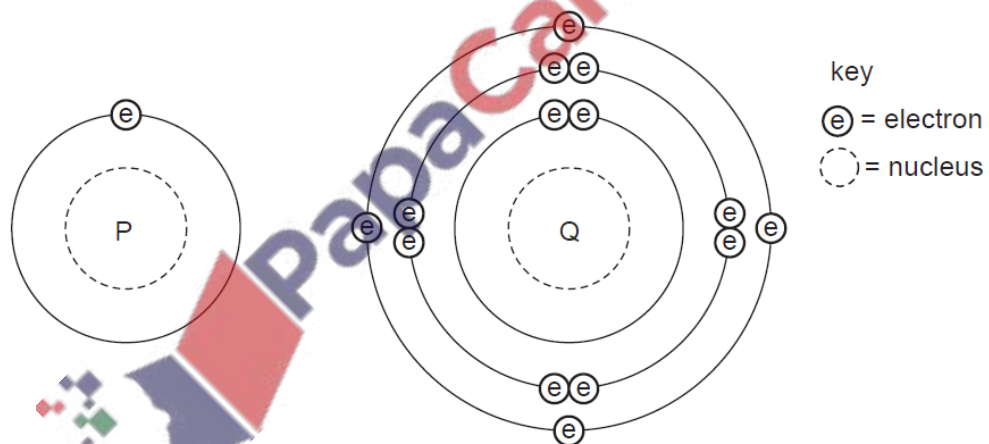

P and Q combine to form a molecule.

What is the formula of this molecule?

- A PQ_4 B PQ C P_2Q D P_4Q

0620_w/11/qp11

28 Which property do **all** metals have?

- A Their boiling points are low.
- B Their densities are low.
- C They conduct electricity.
- D They react with water.

0620_w/10/qp11

27 Which diagram could represent the structure of an alloy?

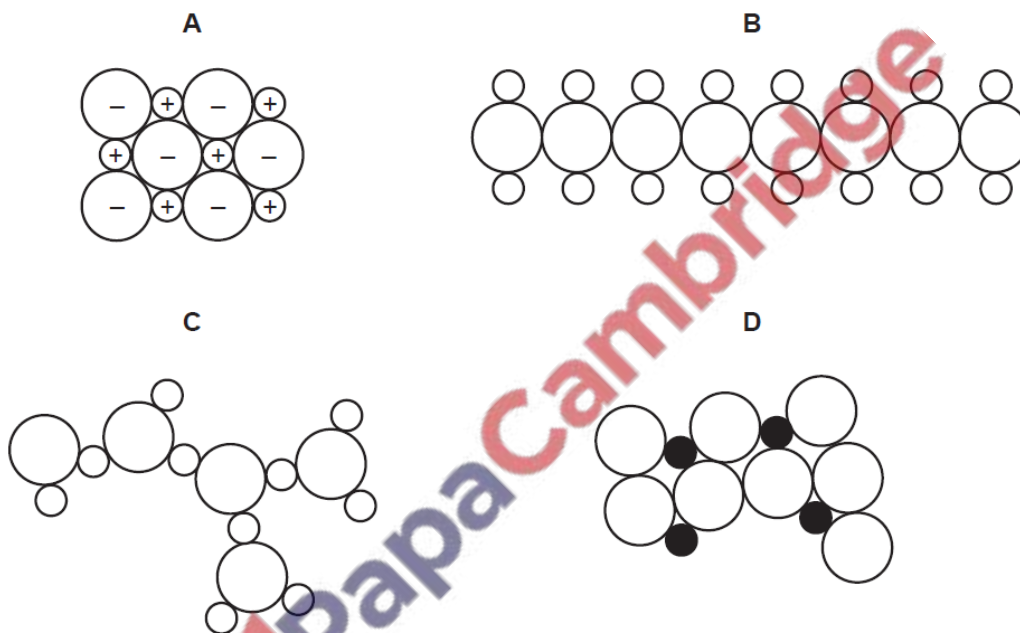

0620_w/10/qp11

9 Which diagram does **not** show the outer shell electrons in the molecule correctly?

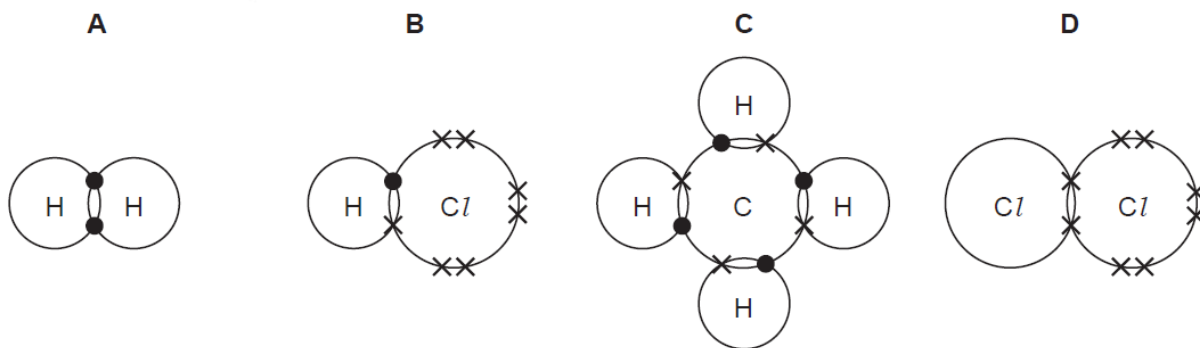

0620_w/10/qp11

8 The electronic structures of atoms X and Y are shown.

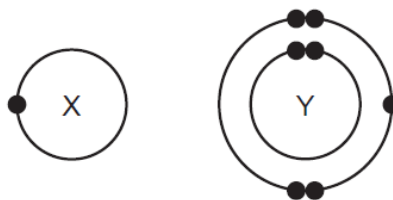

X and Y form a covalent compound.

What is its formula?

- A** XY_5 **B** XY_3 **C** XY **D** X_3Y

0620_w/10/qp11

7 Element X is shiny and can be formed into a sheet by hammering.

Which row correctly describes the properties of element X?

	conducts electricity	melts below 25°C
A	✓	✓
B	✓	x
C	x	✓
D	x	x

0620_w/10/qp11

30 Which property do **all** metals have?

- A** They are soluble in water.
B They conduct electricity.
C They have high melting points.
D They react with dilute sulfuric acid.

0620_w/09/qp11

9 Which change to an atom occurs when it forms a positive ion?

- A It gains electrons.
- B It gains protons.
- C It loses electrons.
- D It loses protons.

0620_w/09/qp11

7 Statements 1, 2 and 3 are about diamond and graphite.

- 1 They are different solid forms of the same element.
- 2 They each conduct electricity.
- 3 They have atoms that form four equally strong bonds.

Which statements are correct?

- A 1 only B 3 only C 1 and 3 D 2 and 3

0620_w/09/qp11

8 Covalent bonds are formed when electrons are1..... . Covalent compounds have2..... electrical conductivity.

Which words correctly complete gaps 1 and 2?

	1	2
A	shared	high
B	shared	low
C	transferred	high
D	transferred	low

0620_w/09/qp11

- 29 A new isotope of a divalent metal is discovered. Some students are asked to predict its properties.

Which student's predictions are correct?

student	number of electrons in outer shell	bonding in the oxide
A	2	covalent
B	2	ionic
C	6	covalent
D	6	ionic

0620_w/08/qp1

- 11 Carbon and chlorine form a chloride.

What is the formula of this chloride?

- A CCl_2 B CCl_4 C $CaCl_2$ D $CaCl_4$

0620_w/08/qp1

- 9 The diagram shows a molecule of hydrogen fluoride.

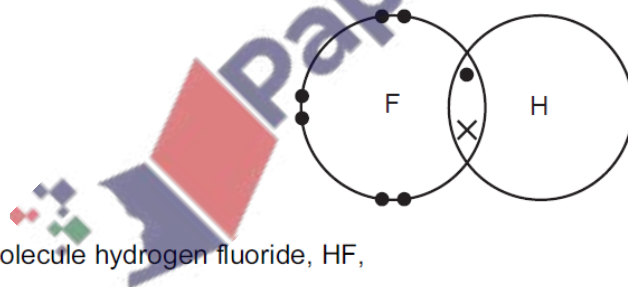

In the molecule hydrogen fluoride, HF,

- A the hydrogen and fluorine share a pair of electrons.
B the hydrogen and fluorine share a pair of protons.
C the hydrogen gives the fluorine an electron.
D the hydrogen gives fluorine a proton.

0620_w/08/qp1

7 Which of the following compounds exist?

	RaAr	RbBr
A	✓	✓
B	✓	x
C	x	✓
D	x	x

0620_w/08/qp1

7 The electronic structures of atoms P and Q are shown.

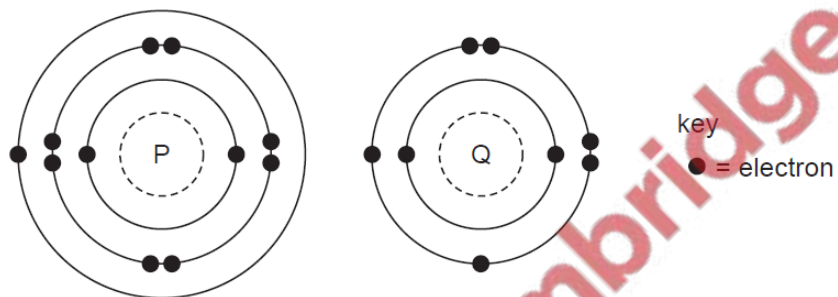

P and Q react to form an ionic compound.

What is the formula of this compound?

- A** PQ_2 **B** P_2Q **C** P_2Q_6 **D** P_6Q_2

0620_s/12/qp11



8 The diagrams show the structures of two forms, P and Q, of a solid element.

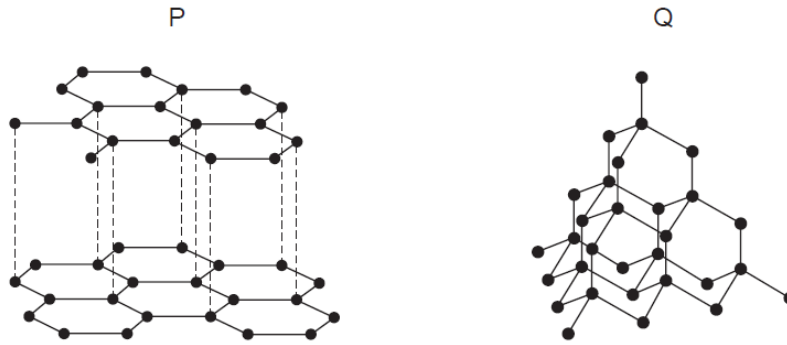

What are suitable uses of P and Q, based on their structures?

	use of solid P	use of solid Q
A	drilling	drilling
B	lubricating	drilling
C	drilling	lubricating
D	lubricating	lubricating

0620_s/12/qp11

6 Which is a simple covalent molecule?

	conducts electricity		volatile
	when solid	when molten	
A	✓	✓	x
B	✓	x	✓
C	x	✓	x
D	x	x	✓

0620_s/12/qp11

6 In the diagrams, circles of different sizes represent atoms of different elements.

Which diagram represents hydrogen chloride gas?

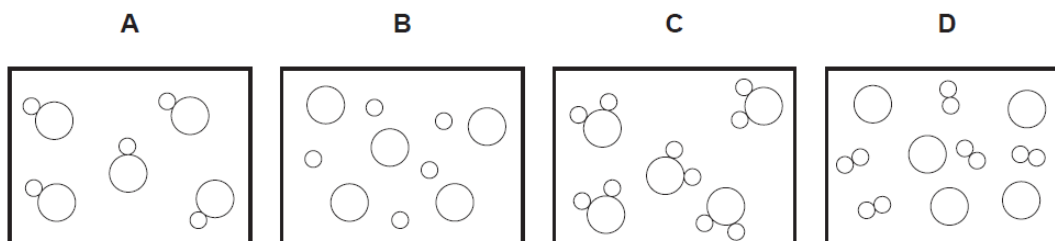

0620_s/11/qp11

4 Which two elements react together to form an ionic compound?

element	electronic structure
W	2,4
X	2,8
Y	2,8,1
Z	2,8,7

A W and X

B X and Y

C Y and Z

D Z and W

0620_s/11/qp11

8 Element X has six electrons in its outer shell.

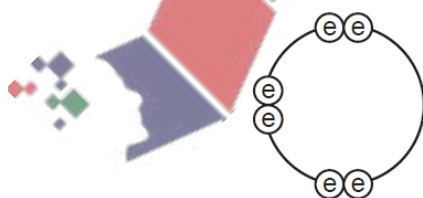

key

⊙ = electron

How could the element react?

A by gaining two electrons to form a positive ion

B by losing six electrons to form a negative ion

C by sharing two electrons with two electrons from another element to form two covalent bonds

D by sharing two electrons with two electrons from another element to form four covalent bonds

0620_s/10/qp11

9 In which compounds are pairs of electrons shared between atoms?

- 1 sodium chloride
- 2 methane
- 3 lead bromide

A 1 only B 2 only C 1 and 3 D 1, 2 and 3

0620_s/10/qp11

7 Which name is given to mixtures of metals?

- A alloys
- B compounds
- C ores
- D salts

0620_s/10/qp11

27 Which diagram represents the structure of an alloy?

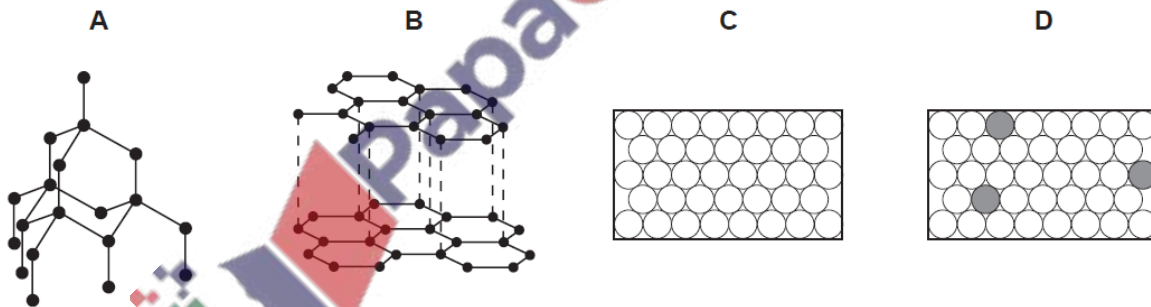

0620_s/09/qp11

8 Element V forms an acidic, covalent oxide.

Which row in the table shows how many electrons there could be in the outer shell of an atom of V?

	1	2	6	7
A	✓	x	x	x
B	✓	✓	x	x
C	x	x	x	✓
D	x	x	✓	✓

0620_s/09/qp11

9 When sodium chloride is formed from its elements, each chlorine atom1..... one2.....

Which words correctly complete gaps 1 and 2?

	1	2
A	gains	electron
B	gains	proton
C	loses	electron
D	loses	proton

0620_s/09/qp11

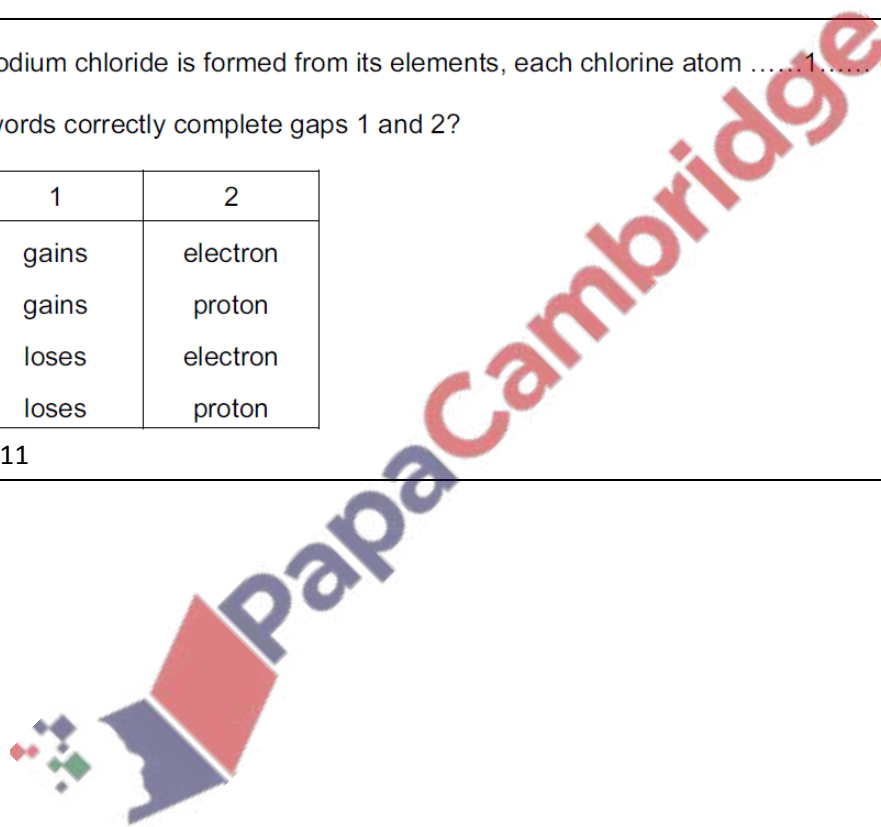

7 The diagrams show the structures of two forms, P and Q, of a solid element.

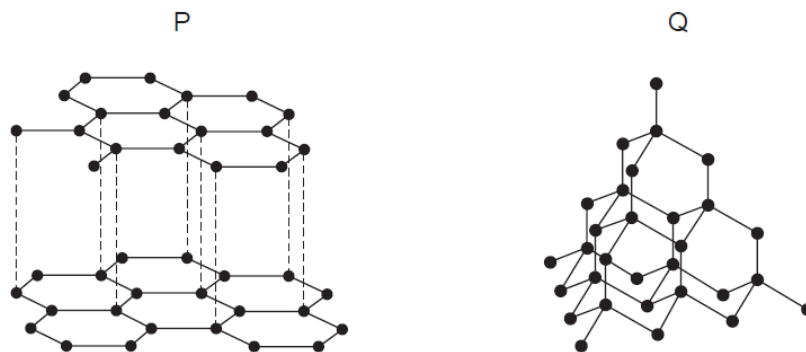

What are suitable uses of P and Q, based on their structures?

	use of solid P	use of solid Q
A	drilling	drilling
B	drilling	lubricating
C	lubricating	drilling
D	lubricating	lubricating

0620_s/09/qp11

26 The proton numbers of four elements are shown.

Which element forms a singly charged positive ion in its salts?

element	proton number
A	34
B	35
C	36
D	37

0620_s/08/qp1

18 When written as formulae, which compound has the greatest number of oxygen atoms?

- A** calcium oxide
- B** copper(II) oxide
- C** iron(III) oxide
- D** potassium oxide

0620_s/08/qp1

- 8 The diagram shows the outer shell electron arrangement of compound J that contains the elements Y and Z.

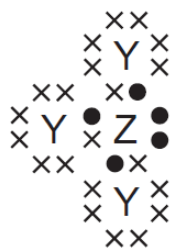

What type of compound is J?

- A an alloy
- B a macromolecule
- C covalent
- D ionic

0620_s/08/qp1

- 9 The electronic structures of atoms P and Q are shown.

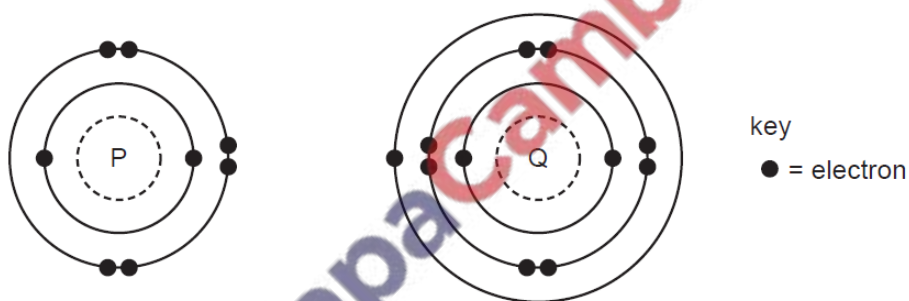

P and Q react to form an ionic compound.

What is the formula of this compound?

- A PQ_2
- B P_2Q
- C P_2Q_6
- D P_6Q_2

0620_s/08/qp1

- 10 For which compound is the formula correct?

	compound	formula
A	ammonium chloride	NH_3Cl
B	copper(II) sulphide	CuS
C	iron(II) sulphide	Fe_3S
D	silver nitrate	Ag_2NO_3

0620_s/08/qp1

11 The diagram shows a molecule of vinyl chloride (used to make pvc).



key

- a carbon atom
- a chlorine atom
- a hydrogen atom

What is the formula of vinyl chloride?

- A** CH_2Cl_3 **B** CH_3Cl_2 **C** C_2HCl_3 **D** $\text{C}_2\text{H}_3\text{Cl}$

0620_s/08/qp1

7 Which of the following can be used as a lubricant?

	graphite	a liquid fraction from petroleum
A	✓	✓
B	✓	x
C	x	✓
D	x	x

0620_s/08/qp1

23 The diagram shows an outline of part of the Periodic Table.

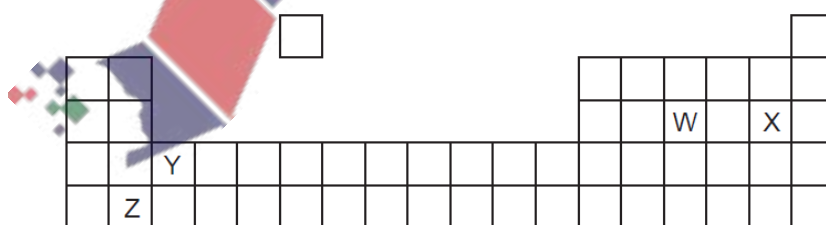

Which two elements could form a covalent compound?

- A** W and X **B** W and Y **C** X and Y **D** X and Z

0620_s/07/qp1

10 Boron, B, forms an oxide.

Which equation is correctly balanced?

- A $2B + 3O_2 \rightarrow B_2O_3$
- B $2B + 3O_2 \rightarrow 2B_2O_3$
- C $4B + 2O_2 \rightarrow 2B_2O_3$
- D $4B + 3O_2 \rightarrow 2B_2O_3$

0620_s/07/qp1

9 In the diagrams, circles of different sizes represent atoms of different elements.

Which diagram can represent hydrogen chloride gas?

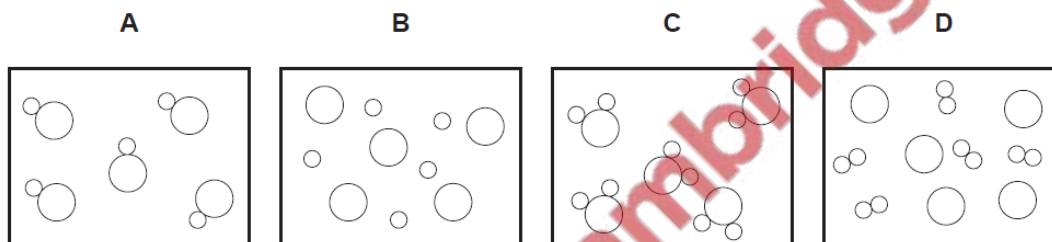

0620_s/07/qp1

7 The diagram shows the structure of methane.



What is the total number of electrons used for bonding in this molecule?

- A 2
- B 4
- C 8
- D 10

0620_s/07/qp1

18 The diagram shows the positions of some elements in the Periodic Table.

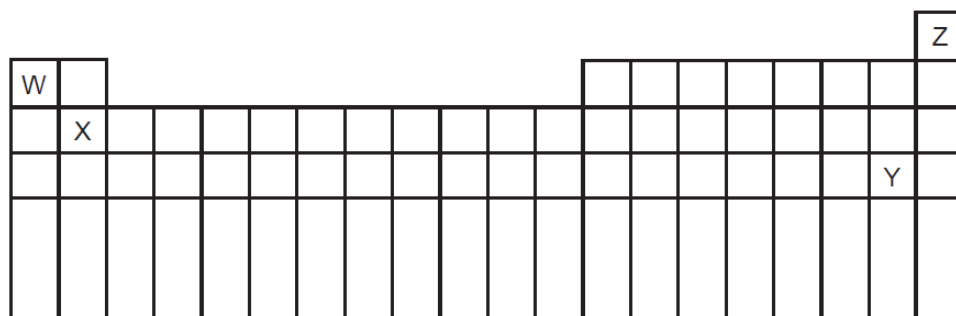

Which elements form ionic bonds with oxygen?

- A W only
- B W and X only
- C Y only
- D Y and Z only

0620_s/06/qp1

9 The diagrams show the molecules of three elements.



1



2



3

Which of these elements are present in water?

- A 1 and 2 only
- B 1 and 3 only
- C 2 and 3 only
- D 1, 2 and 3

0620_s/06/qp1

8 For which compound is the formula correct?

	compound	formula
A	ammonia	NH_4
B	carbon dioxide	CO
C	potassium oxide	P_2O
D	zinc chloride	ZnCl_2







0620_s/06/qp1

6 In the molecules CH_4 , HCl and H_2O , which atoms use **all** of their outer shell electrons in bonding?

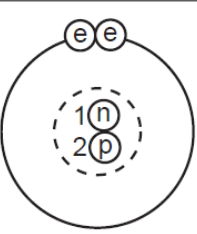
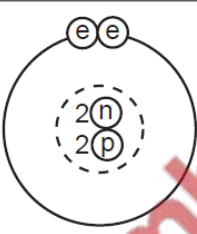
- A C and Cl
- B C and H
- C Cl and H
- D H and O

0620_s/06/qp1

4 The rows P, Q and R in the table show three pairs of structures.

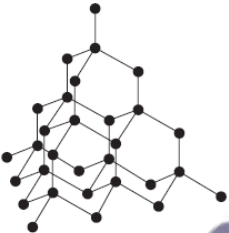
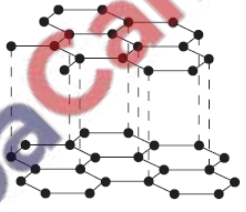
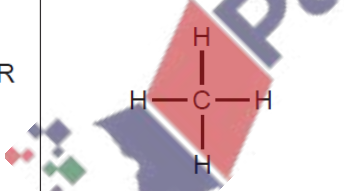
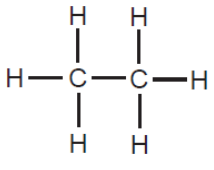
P			<p>key</p> <ul style="list-style-type: none">  electron  neutron  proton  nucleus <ul style="list-style-type: none">  atoms of the same element
Q			
R			

Which pair or pairs are isotopes?

- A P only
- B P and Q only
- C Q only
- D Q and R only

0620_s/06/qp1

3 Five elements have proton numbers 10, 12, 14, 16 and 18.

What are the proton numbers of the three elements that form oxides?

- A 10, 12 and 14
- B 10, 14 and 18
- C 12, 14 and 16
- D 14, 16 and 18

0620_s/06/qp1

27 Mild steel is an alloy of iron and carbon.

How does the carbon affect the properties of mild steel?

- A The carbon makes the alloy a better conductor of electricity than iron.
- B The carbon makes the alloy harder than the iron.
- C The carbon makes the alloy softer than the iron.
- D The carbon stops the iron rusting.

0620_s/05/qp1

10 For which compound is the formula correct?

	compound	formula
A	ammonia	NH_4
B	carbon monoxide	CO_2
C	iron(III) oxide	Fe_3O_2
D	zinc hydroxide	$\text{Zn}(\text{OH})_2$

0620_s/05/qp1

-
- 7 The 'lead' in a pencil is made of a mixture of graphite and clay.

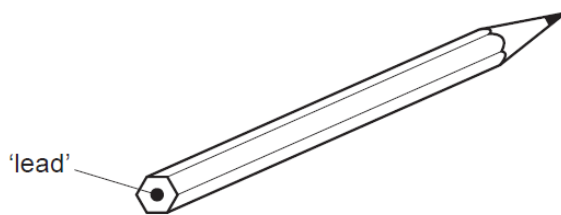

If the percentage of graphite is increased, the pencil slides across the paper more easily.

Why is this?

- A Graphite conducts electricity.
- B Graphite is a form of carbon.
- C Graphite is a lubricant.
- D Graphite is a non-metal.

0620_s/05/qp1

- 8 Which statement about gaseous hydrogen chloride and solid potassium chloride is correct?

- A Hydrogen chloride is covalent but potassium chloride is ionic.
- B Hydrogen chloride is ionic but potassium chloride is covalent.
- C They are both covalent compounds.
- D They are both ionic compounds.

0620_s/05/qp1

- 9 Which two elements form an alloy when they are heated together?

- A chlorine and hydrogen
- B chlorine and zinc
- C copper and hydrogen
- D copper and zinc

0620_s/05/qp1

7 In the diagrams, circles of different sizes represent atoms of different elements.

Which diagram can represent hydrogen chloride gas?

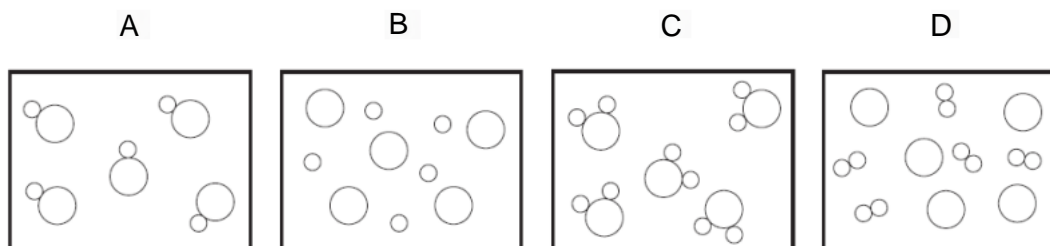

0620_s/04/qp1

8 How many electrons are shared between the atoms in a molecule of methane, CH_4 , and in a molecule of water, H_2O ?

	methane	water
A	4	2
B	4	4
C	8	2
D	8	4

0620_s/04/qp1

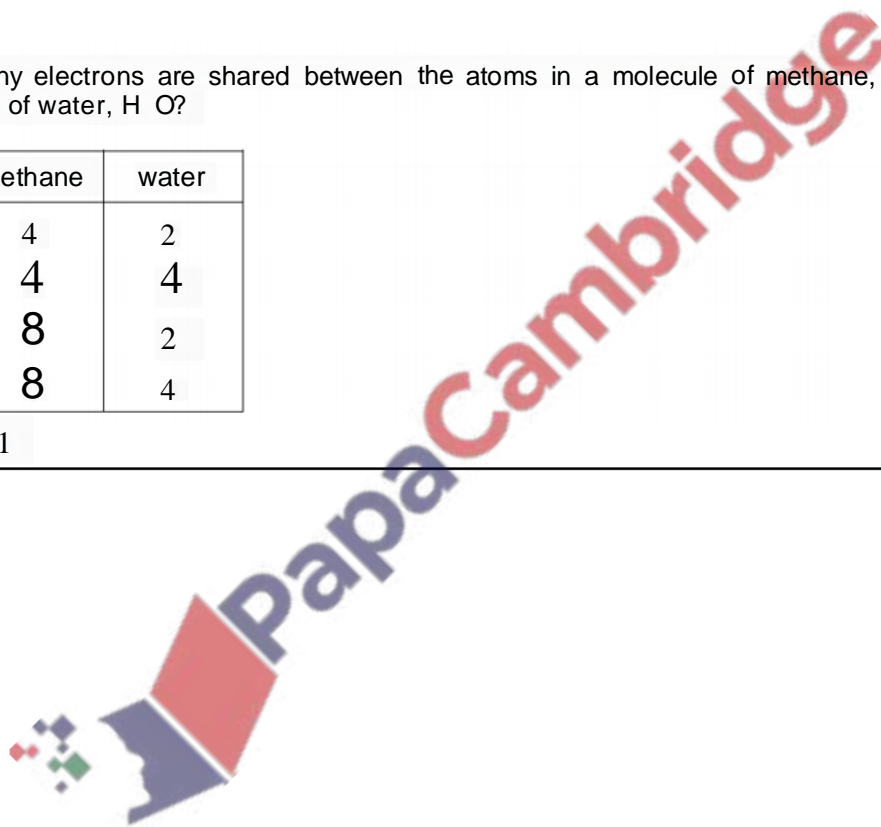

10 The diagram shows a model of a molecule containing carbon, hydrogen and oxygen.

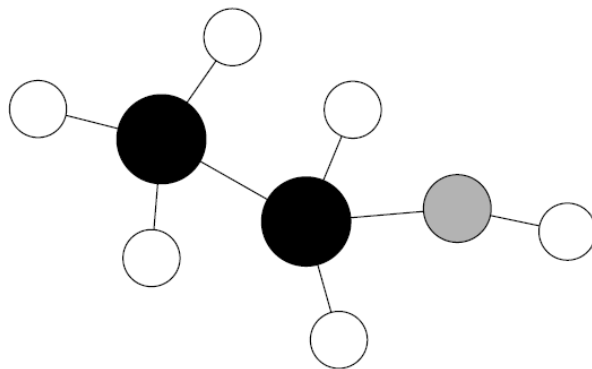

How many atoms of each element are in the molecule?

	carbon	hydrogen	oxygen
A	1	6	2
B	2	5	1
C	2	6	1
D	6	2	1

0620_s/03/qp1

8 Strontium, Sr, is a metal that forms an ionic chloride SrCl_2 .

Sulphur, S, is a non-metal that forms a covalent chloride SCl_2 .

Which compound is likely to have the higher melting point (m.p.) and which is more soluble in water?

	higher m.p.	more soluble in water
A	SrCl_2	SrCl_2
B	SrCl_2	SCl_2
C	SCl_2	SrCl_2
D	SCl_2	SCl_2

0620_s/03/qp1

29 The following statements are about alloys.

- Alloys are ...X....
- ...Y... alloys conduct electricity.

Which words complete the statements?

	X	Y
A	compounds	All
B	compounds	Some
C	mixtures	All
D	mixtures	Some

0620_w/07/qp1

7 The table shows the electronic structures of four atoms.

atom	electronic structure
W	2,8,1
X	2,8,4
Y	2,8,7
Z	2,8,8

Which two atoms combine to form a covalent compound?

- A** W and X **B** W and Y **C** X and Y **D** X and Z

0620_w/07/qp1

8 The following statement is about chemical bonds.

Covalent bonds are formed by the ...1... of electrons. Covalent substances have ...2... electrical conductivity.

Which words complete the statement?

	1	2
A	sharing	high
B	sharing	low
C	transfer	high
D	transfer	low

0620_w/07/qp1

10 A gas has the molecular formula NOCl .

Which diagram could show molecules of the pure gas NOCl ?

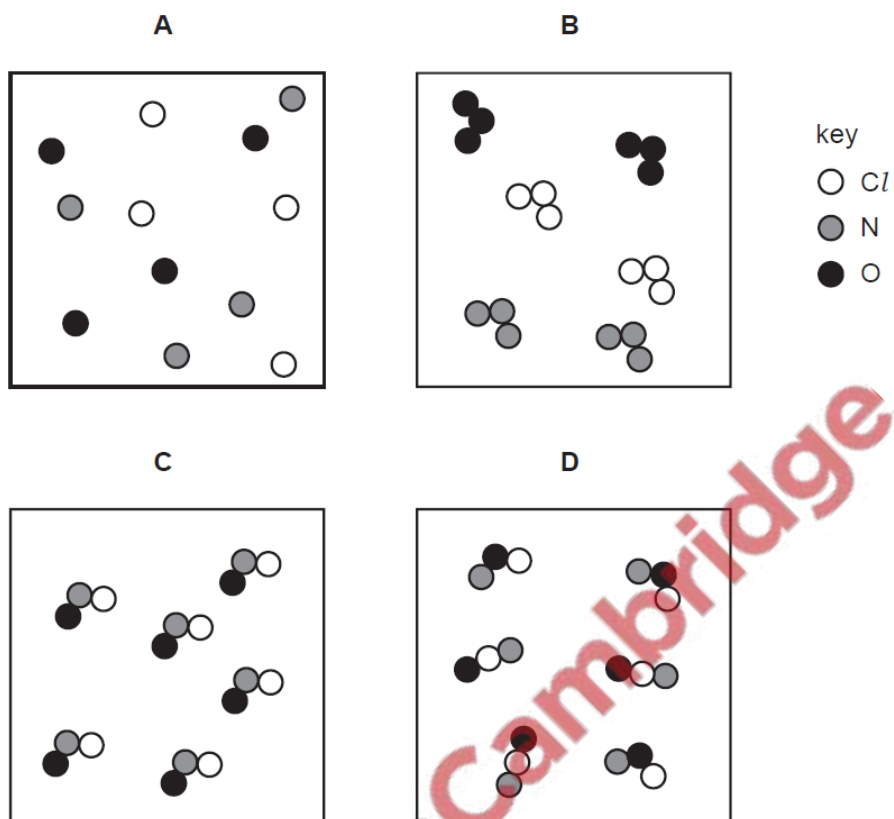

0620_w/06/qp1

9 Magnesium and sulphur each form a chloride.

What could be the formulae of these chlorides?

	magnesium	sulphur
A	Mg_2Cl	S_2Cl
B	Mg_2Cl	SCl_2
C	MgCl_2	S_2Cl
D	MgCl_2	SCl_2

0620_w/06/qp1

6 The table shows the electronic structures of four atoms.

atom	electronic structure
W	2,1
X	2,7
Y	2,8,4
Z	2,8,8

Which two atoms combine to form an ionic compound?

- A** W and X **B** W and Y **C** X and Y **D** X and Z

0620_w/06/qp1

7 Element X forms an acidic, covalent oxide.

Which row in the table shows how many electrons there could be in the outer shell of an atom of X?

	1	2	6	7
A	✓	x	x	x
B	✓	✓	x	x
C	x	x	x	✓
D	x	x	✓	✓

0620_w/06/qp1

8 The diagram shows the structure of hydrogen peroxide.

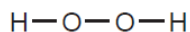

What is the total number of electrons used for bonding in this molecule?

- A** 3 **B** 4 **C** 6 **D** 8

0620_w/05/qp1

7 Bottles of sodium hydroxide, sodium chloride and sugar have lost their labels.

Students test a sample from each bottle. Their results are shown in the table.

bottle	addition of water	conductivity of solution
1	forms an alkaline solution	conducts electricity
2	forms a neutral solution	conducts electricity
3	forms a neutral solution	does not conduct electricity

What are the correct labels for each bottle?

	bottle 1	bottle 2	bottle 3
A	sodium hydroxide	sodium chloride	sugar
B	sodium hydroxide	sugar	sodium chloride
C	sodium chloride	sugar	sodium hydroxide
D	sugar	sodium hydroxide	sodium chloride

0620_w/05/qp1

26 Which substance is a metal?

	electrical conductivity (solid)	electrical conductivity (molten)
A	high	high
B	high	low
C	low	high
D	low	low

0620_w/04/qp1

7 Which compound has ionic bonds?

- A** hydrogen chloride
- B** methane
- C** sodium chloride
- D** water

0620_w/04/qp1

- 3 The apparatus shown **cannot** be used to determine the melting point of sodium chloride, Na^+Cl^- .

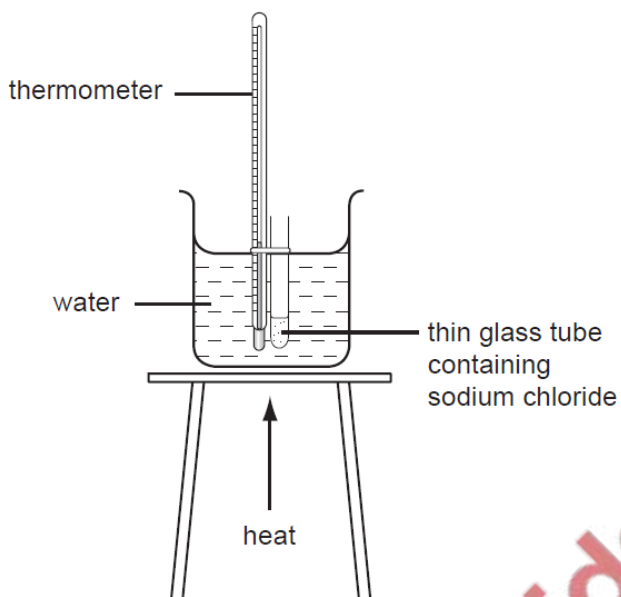

Why is this?

	melting point of sodium chloride is greater than 100°C	sodium chloride dissolves in the water
A	✓	✓
B	✓	x
C	x	✓
D	x	x

0620_w/04/qp1

- 11 Carbon and chlorine form a chloride.

What is the formula of this chloride?

- A CCl_2
- B CCl_4
- C CaCl_2
- D CaCl_4

0620_w/03/qp1

9 The diagrams show the bonding in three covalent molecules.

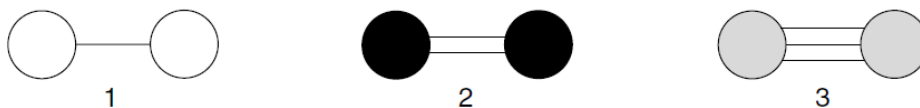

Which of these molecules combine to form ammonia?

- A 1 and 2
- B 1 and 3
- C 2 and 3
- D 1, 2 and 3

0620_w/03/qp1

7 Which of the following can be used as a lubricant?

	graphite	a liquid fraction from petroleum
A	✓	✓
B	✓	x
C	x	✓
D	x	x

0620_w/03/qp1

10 A gas has the molecular formula NOCl.

Which diagram could show molecules of the pure gas NOCl?

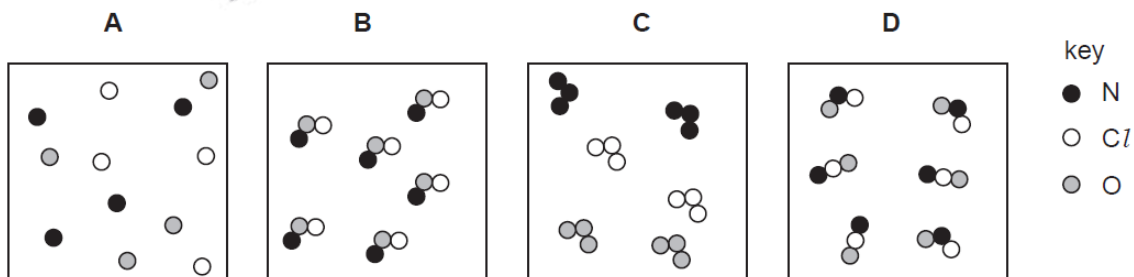

0620_w/02/qp1

8 The diagram shows an electric circuit.

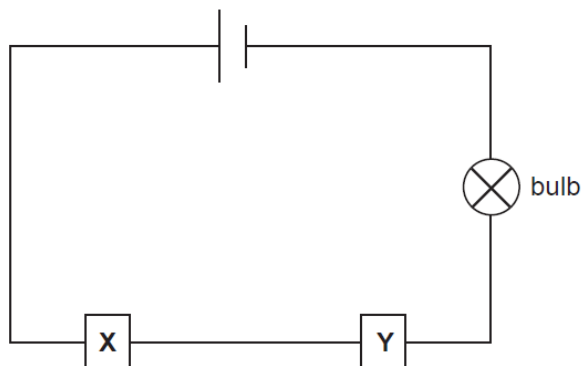

For which two substances at X and Y does the bulb light up?

	X	Y
A	copper	graphite
B	copper	poly(ethene)
C	rubber	graphite
D	rubber	poly(ethene)

0620_w/02/qp1

7 The electronic structures of two atoms, X and Y, are shown.

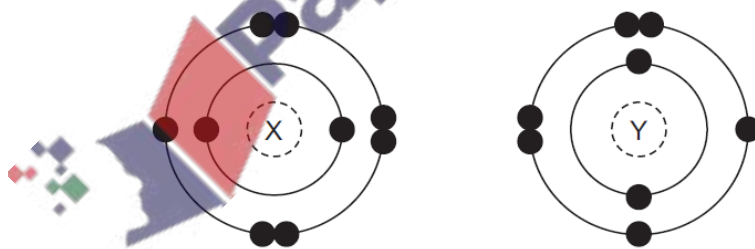

X and Y combine together to form a compound.

What is the type of bonding in the compound and what is the formula of the compound?

	type of bonding	formula
A	covalent	X_2Y
B	covalent	XY_2
C	ionic	XY_2
D	ionic	X_2Y

0620_s/14/qp12

11 Which substance will **not** conduct electricity?

- A aluminium
- B copper
- C plastic
- D steel

0620_s/14/qp11

9 A compound contains one atom of calcium, two atoms of hydrogen and two atoms of oxygen.

What is the correct chemical formula of the compound?

- A CaO_2H_2
- B HOCaOH
- C H_2CaO_2
- D $\text{Ca}(\text{OH})_2$

0620_s/14/qp11

8 Solid F is an element.

Solid G is a compound.

Neither solid conducts electricity but G conducts electricity when dissolved in water.

These properties suggest that F is1..... and that G is2..... with3..... bonds.

Which words correctly complete gaps 1, 2 and 3?

	1	2	3
A	diamond	AgCl	covalent
B	diamond	NaCl	ionic
C	graphite	AgCl	ionic
D	graphite	NaCl	covalent

0620_s/14/qp11

- 6 The 'lead' in a pencil is made of a mixture of graphite and clay.

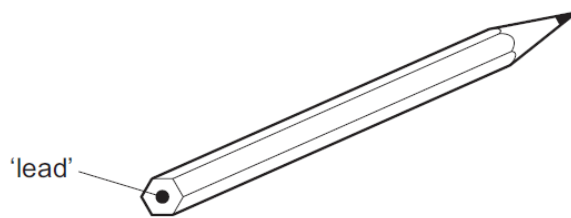

When the percentage of graphite is increased, the pencil slides across the paper more easily.

Which statement explains this observation?

- A Graphite has a high melting point.
- B Graphite is a form of carbon.
- C Graphite is a lubricant.
- D Graphite is a non-metal.

0620_s/14/qp11

- 6 For which substance is the type of bonding **not** correct?

	substance	type of bonding		
		ionic	covalent	metallic
A	chlorine		✓	
B	potassium bromide	✓		
C	sodium			✓
D	sodium chloride		✓	

0620_s/13/qp11

29 The diagram represents the structure of substance S.

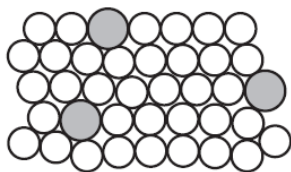

What is S?

- A an alloy
- B an ionic solid
- C a macromolecule
- D a pure metal

0620_s/13/qp12

8 Element X has six electrons in its outer shell.

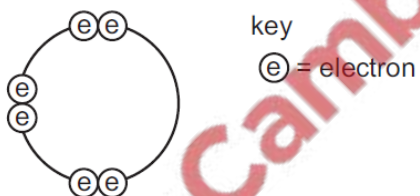

How could the element react?

- A by gaining two electrons to form a positive ion
- B by losing six electrons to form a negative ion
- C by sharing two electrons with two electrons from another element to form two covalent bonds
- D by sharing two electrons with two electrons from another element to form four covalent bonds

0620_s/13/qp12

9 The diagram shows an incomplete circuit.

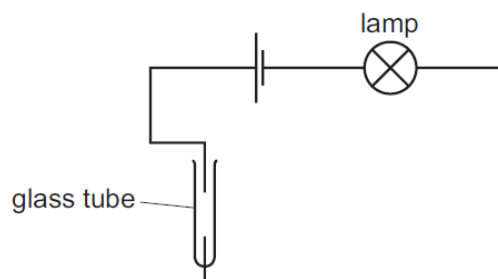

Which substance causes the lamp to light when added to the glass tube?

- A aqueous sodium chloride
- B aqueous sugar
- C solid sodium chloride
- D solid sugar

0620_s/13/qp12

6 Electrons from each element are shared by both of the elements in a compound.

Which compound matches this description?

- A lead bromide
- B sodium chloride
- C water
- D zinc oxide

0620_s/13/qp12

22 Five elements have proton numbers 10, 12, 14, 16 and 18.

What are the proton numbers of the three elements that form oxides?

- A 10, 12 and 14
- B 10, 14 and 18
- C 12, 14 and 16
- D 14, 16 and 18

0620_s/12/qp11

- 3 In 1985 the fullerenes were discovered. They are solid forms of the element carbon. The structure of the C₆₀ fullerene is given below.

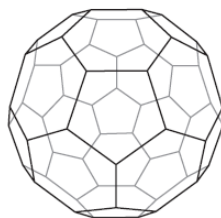

(a) (i) In the C₆₀ fullerene, how many other carbon atoms is each carbon atom bonded to?
..... [1]

(ii) Another fullerene has a relative molecular mass of 840.
How many carbon atoms are there in one molecule of this fullerene?
..... [1]

(b) Fullerenes are soluble in liquid hydrocarbons such as octane. The other solid forms of carbon are insoluble.
Describe how you could obtain crystals of fullerenes from soot which is a mixture of fullerenes and other solid forms of carbon.
.....
.....
.....
..... [3]

(c) A mixture of a fullerene and potassium is an excellent conductor of electricity.
(i) Which other form of solid carbon is a good conductor of electricity?
..... [1]

(ii) Explain why metals, such as potassium, are good conductors of electricity.
.....
..... [2]

(iii) The mixture of fullerene and potassium has to be stored out of contact with air. There are substances in unpolluted air which will react with potassium.
Name **two** potassium compounds which could be formed when potassium is exposed to air.
..... [2]

[Total: 10]

7 Nitrogen can form ionic compounds with reactive metals and covalent compounds with non-metals.

(a) Nitrogen reacts with lithium to form the ionic compound lithium nitride, Li_3N .

(i) Write the equation for the reaction between lithium and nitrogen.

..... [2]

(ii) Lithium nitride is an ionic compound. Draw a diagram which shows its formula, the charges on the ions and the arrangement of the valency electrons around the negative ion.

Use x for an electron from a lithium atom.
Use o for an electron from a nitrogen atom.

[2]

(b) Nitrogen fluoride is a covalent compound.

(i) Draw a diagram showing the arrangement of the valency electrons in one molecule of the covalent compound nitrogen trifluoride, NF_3 .

Use x for an electron from a nitrogen atom.
Use o for an electron from a fluorine atom.



[2]

(ii) Lithium nitride has a high melting point, 813°C . Nitrogen trifluoride has a low melting point, -207°C .

Explain why the melting points are different.

.....
.....
..... [2]

[Total: 8]

- 2 Two macromolecular forms of carbon are graphite and diamond. The structures of graphite and diamond are given below.

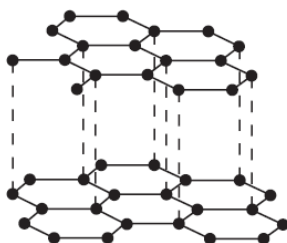

graphite

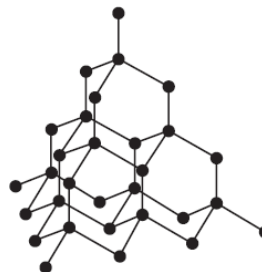

diamond

- (a) Explain in terms of its structure why graphite is soft and is a good conductor of electricity.

.....
.....
.....
.....
..... [3]

- (b) State **two** uses of graphite which depend on the above properties.

It is soft

It is a good conductor of electricity

..... [2]

- (c) Silicon(IV) oxide also has a macromolecular structure.

- (i) Describe the macromolecular structure of silicon(IV) oxide.

.....
..... [1]

- (ii) Predict **two** physical properties which diamond and silicon(IV) oxide have in common.

.....
..... [2]

[Total: 8]

2 (a) The diagram shows the lattice of a typical ionic compound.

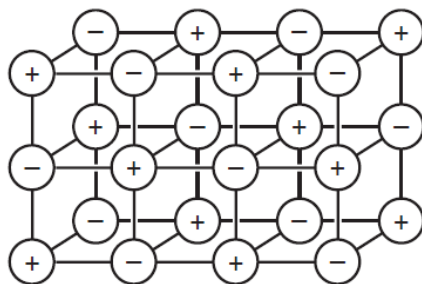

(i) Explain the term *ionic lattice*.

.....
..... [2]

(ii) In this lattice, the ratio of positive ions to negative ions is 1:1.
In the lattice of a different ionic compound, the ratio of positive ions to negative ions is 1:2.
Suggest why this ratio varies in different ionic compounds.

..... [1]

(iii) Give **three** physical properties of ionic compounds.

.....
.....
..... [3]

(b) Strontium oxide is an ionic compound. Draw a diagram which shows its formula, the charges on the ions and the arrangement of the **valency** electrons around the negative ion.

The electron distribution of a strontium atom is 2 + 8 + 18 + 8 + 2.

Use o to represent an electron from a strontium atom.

Use x to represent an electron from an oxygen atom.

[3]

[Total: 9]

-
- (b) The halogens react with other non-metals to form covalent compounds.
Draw a diagram which shows the arrangement of the valency electrons in one molecule of the covalent compound arsenic trifluoride.

The electron distribution of an arsenic atom is $2 + 8 + 18 + 5$.

Use x to represent an electron from an arsenic atom.

Use o to represent an electron from a fluorine atom.

[3]

0620/w13/qp32

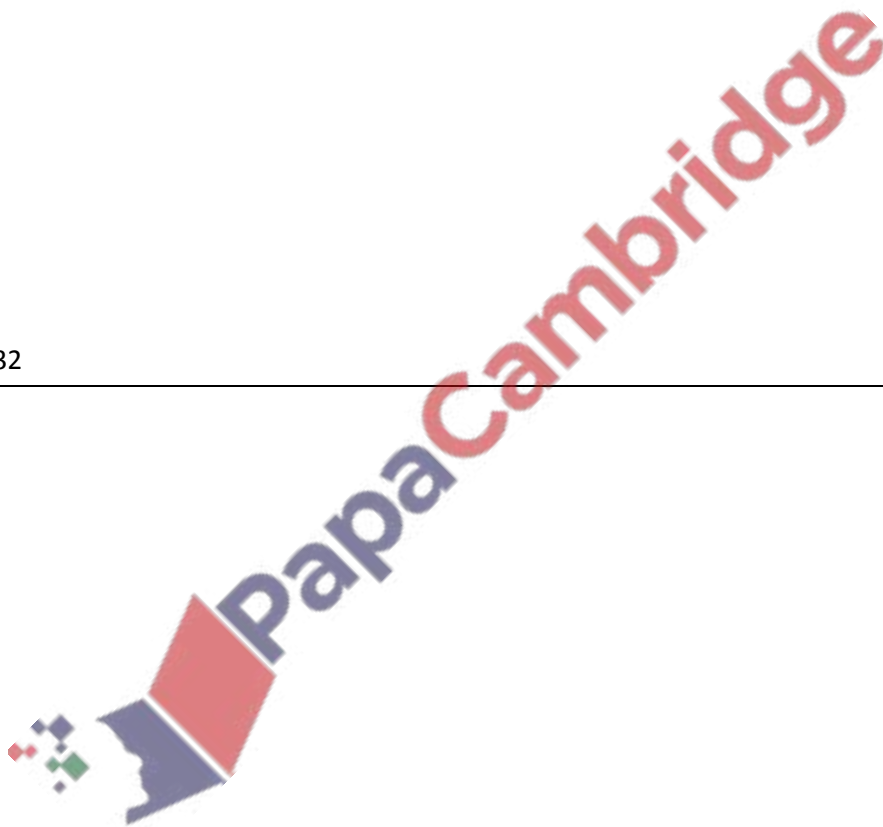

- 1 The table gives the melting points, the boiling points and the electrical properties of six substances A to F.

substance	melting point /°C	boiling point /°C	electrical conductivity as a solid	electrical conductivity as a liquid
A	-210	-196	does not conduct	does not conduct
B	777	1627	does not conduct	good conductor
C	962	2212	good conductor	good conductor
D	-94	63	does not conduct	does not conduct
E	1410	2355	does not conduct	does not conduct
F	1064	2807	good conductor	good conductor

- (a) Which **two** substances could be metals? [1]
- (b) Which substance could be nitrogen? [1]
- (c) Which substance is an ionic solid? [1]
- (d) Which substance is a liquid at room temperature? [1]
- (e) Which substance has a giant covalent structure similar to that of diamond? [1]
- (f) Which **two** substances could exist as simple covalent molecules? [1]

[Total: 6]

0620/w13/qp32

6 Until recently, arsenic poisoning, either deliberate or accidental, has been a frequent cause of death. The symptoms of arsenic poisoning are identical with those of a common illness, cholera. A reliable test was needed to prove the presence of arsenic in a body.

(a) In 1840, Marsh devised a reliable test for arsenic.

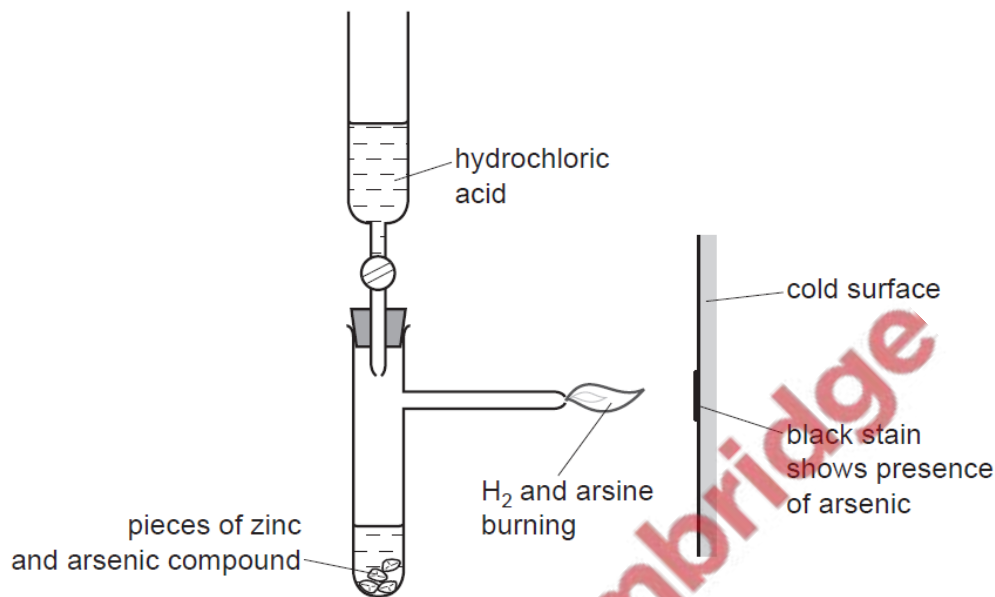

Hydrogen is formed in this reaction. Any arsenic compound reacts with this hydrogen to form arsine which is arsenic hydride, AsH₃. The mixture of hydrogen and arsine is burnt at the jet and arsenic forms as a black stain on the glass.

(i) Write an equation for the reaction which forms hydrogen.

..... [2]

(ii) Draw a diagram which shows the arrangement of the outer (valency) electrons in one molecule of the covalent compound arsine.

The electron distribution of arsenic is 2 + 8 + 18 + 5.

Use x to represent an electron from an arsenic atom.

Use o to represent an electron from a hydrogen atom.

[2]

4 Zinc alloys have been used for over 2500 years.

(a) (i) Explain the phrase *zinc alloy*.

.....
..... [1]

(ii) Making alloys is still a major use of zinc. State **one** other large scale use of zinc.

..... [1]

(iii) Describe the bonding in a typical metal, such as zinc, and then explain why it is malleable. You may use a diagram to illustrate your answer.

.....
.....
..... [3]

(iv) Suggest why the introduction of a different atom into the structure makes the alloy less malleable than the pure metal.

.....
..... [2]

0620/w12/qp33

-
- (iii) Draw a diagram showing the arrangement of the outer (valency) electrons in one molecule of methanol.

Use x to represent an electron from a carbon atom.

Use o to represent an electron from a hydrogen atom.

Use • to represent an electron from an oxygen atom.

[3]

0620/w12/qp32

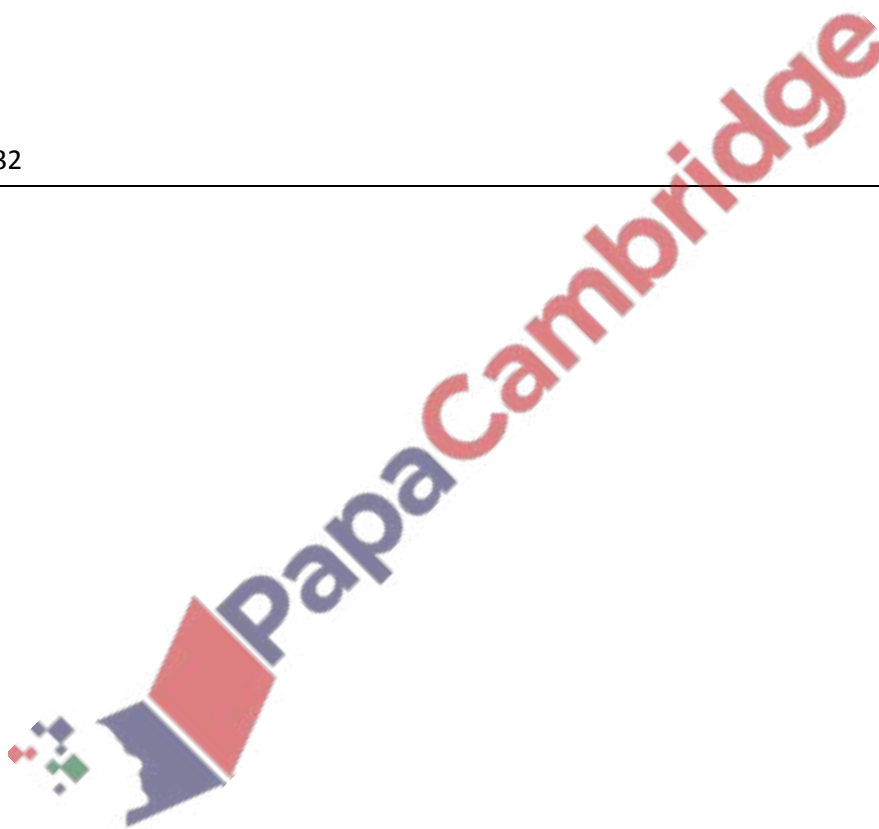

1 This question is concerned with the elements in Period 5, Rb to Xe.

(a) The electron distributions of some of these elements are given in the following list.

- element **A** $2 + 8 + 18 + 8 + 2$
element **B** $2 + 8 + 18 + 18 + 8$
element **C** $2 + 8 + 18 + 18 + 5$
element **D** $2 + 8 + 18 + 18 + 6$
element **E** $2 + 8 + 18 + 18 + 4$
element **F** $2 + 8 + 18 + 18 + 7$

(i) Identify element **C**. [1]

(ii) Which element in the list does not form any compounds?
..... [1]

(iii) Which element in the list forms a chloride of the type XCl_2 ?
..... [1]

(iv) Which **two** elements would react together to form a compound of the type XY_4 ?
..... [1]

(v) Which element in the list would react with cold water to form an alkaline solution and hydrogen?
..... [1]

0620/w12/qp32



PapaCambridge

- 7 Both strontium and sulfur have chlorides of the type XCl_2 . The table below compares some of their properties.

	strontium chloride	sulfur chloride
appearance	white crystals	red liquid
formula	SrCl_2	SCl_2
melting point / °C	874	-120
boiling point / °C	1250	59
conductivity of liquid	good	poor
solubility in water	dissolves to form a neutral solution	reacts to form a solution of pH 1

- (a) (i) Use the data in the table to explain why sulfur chloride is a liquid at room temperature, 25 °C.

.....
..... [2]

- (ii) Strontium is a metal and sulfur is a non-metal. Explain why both have chlorides of the type XCl_2 .
The electron distribution of a strontium atom is 2 + 8 + 18 + 8 + 2.

.....
..... [2]

- (iii) Deduce the name of the acidic compound formed when sulfur chloride reacts with water.

..... [1]

- (iv) Explain the difference in the electrical conductivity of liquid strontium chloride and liquid sulfur chloride.

.....
..... [3]

(c) The structural formula of carbonyl chloride is given below.

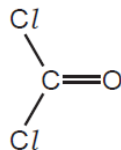

Draw a diagram showing the arrangement of the outer (valency) electrons in one molecule of this covalent compound.

Use o to represent an electron from a carbon atom.

Use x to represent an electron from a chlorine atom.

Use • to represent an electron from an oxygen atom.

[3]

0620/w12/qp31

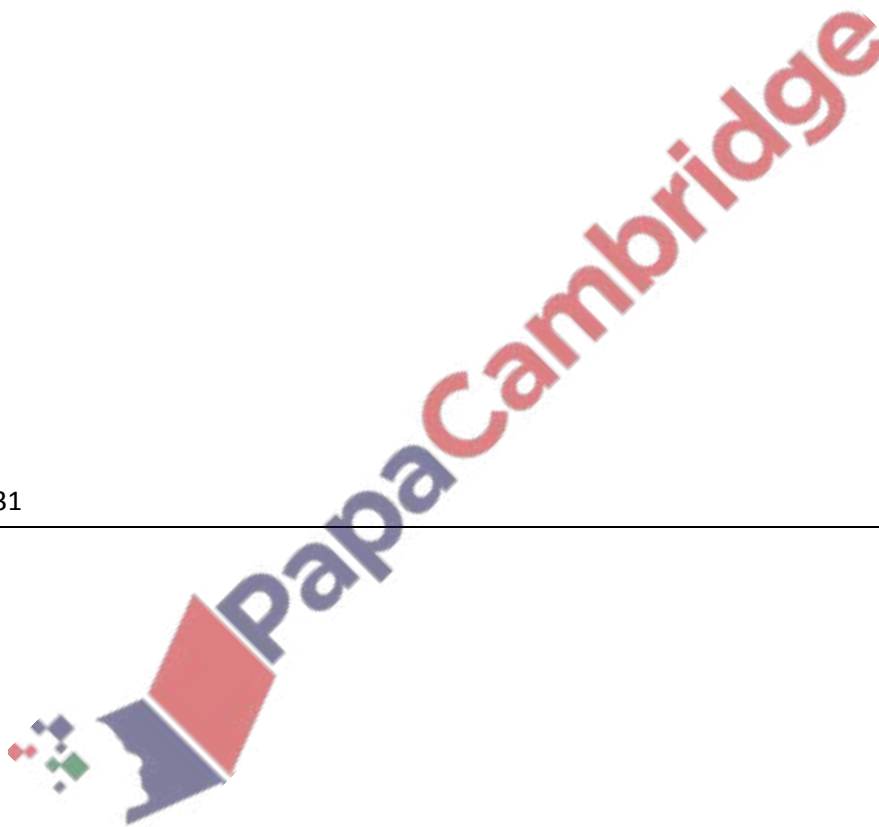

4 Silicon(IV) oxide, SiO_2 , and zirconium(IV) oxide, ZrO_2 , are both macromolecules. They have similar physical properties but silicon(IV) oxide is acidic and zirconium(IV) oxide is amphoteric.

(a) Define the term *macromolecule*.

.....
..... [1]

(b) (i) Predict **three** physical properties of these two oxides.

.....
.....
..... [3]

(ii) Name an element which has the same physical properties as these two oxides.

..... [1]

0620/w12/qp31

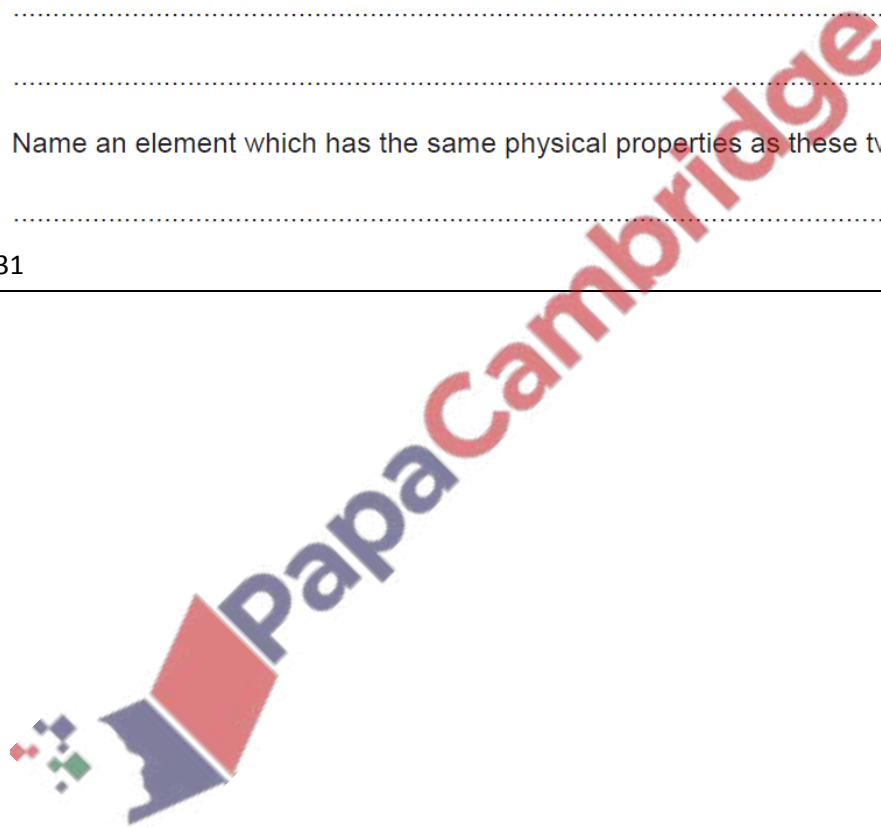

8 There are three types of giant structure - ionic, metallic and giant covalent.

(a) In an ionic compound, the ions are held in a lattice by strong forces.

(i) Explain the term *lattice*.

.....
..... [2]

(ii) Explain how the ions are held together by strong forces.

.....
..... [1]

(b) Describe the bonding in a typical metal.

.....
.....
..... [3]

(c) The electrical conductivities of the three types of giant structure are given in the following table.

type of structure	conductivity of solid	conductivity of liquid
ionic	poor	good
metallic	good	good
giant covalent	poor	poor

Explain the differences in electrical conductivity between the three types of giant structure and the difference, if any, between the solid and liquid states of the same structure.

.....
.....
.....
.....
..... [5]

[Total: 11]

(c) Another compound which contains only nitrogen and hydrogen is hydrazine, N_2H_4 .

Complete the equation for the preparation of hydrazine from ammonia.

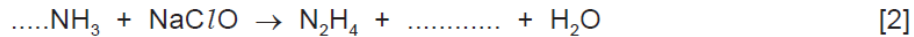

(d) The structural formula of hydrazine is given below.

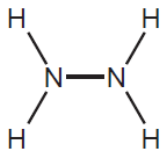

Draw a diagram showing the arrangement of the valency electrons in one molecule of the covalent compound hydrazine.

Use x to represent an electron from a nitrogen atom.

Use o to represent an electron from a hydrogen atom.

[3]

0620/s13/qp31

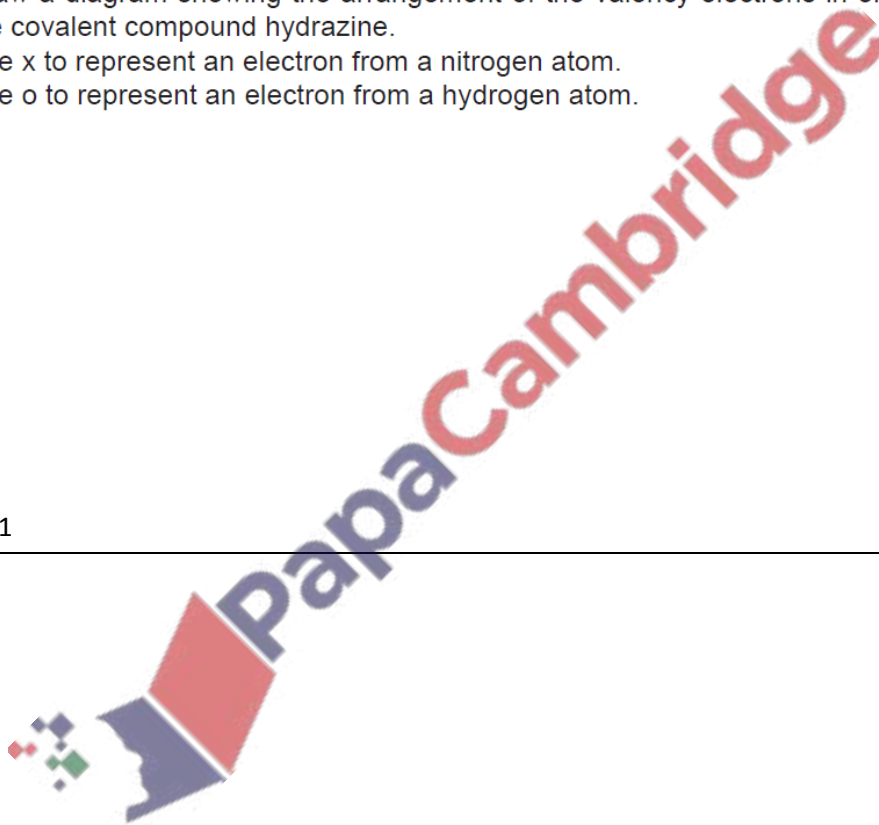

2 An element, **M**, has the electron distribution 2 + 8 + 18 + 3.

(a) Which group in the Periodic Table is element **M** likely to be in?

..... [1]

(b) Predict whether element **M** is a poor or a good conductor of electricity.
Give a reason for your answer.

..... [1]

(c) Binary compounds contain two atoms per molecule, for example HCl .
Identify an element which could form a binary compound with element **M**.

..... [1]

(d) Predict the formula of the sulfate of **M**. The formula of the sulfate ion is SO_4^{2-} .

..... [1]

0620/s13/qp31

2 Diamond and graphite are different forms of the same element, carbon.
Explain the following in terms of their structure.

(a) Graphite is a soft material which is used as a lubricant.

.....
..... [2]

(b) Diamond is a very hard material which is used for drilling and cutting.

.....
..... [2]

(c) Graphite is a good conductor of electricity and diamond is a poor conductor.

.....
.....
..... [2]

[Total: 6]

0620/s12/qp32

1 The table below includes information about some of the elements in Period 2.

element	carbon	nitrogen	fluorine	neon
symbol	C	N	F	Ne
structure	macromolecular	simple molecules N ₂	simple molecules F ₂	single atoms Ne
boiling point/°C	4200	-196	-188	-246

(a) Why does neon exist as single atoms but fluorine exists as molecules?

.....
..... [2]

(b) What determines the order of the elements in a period?

..... [1]

(c) When liquid nitrogen boils the following change occurs.

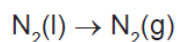

The boiling point of nitrogen is very low even though the bond between the atoms in a nitrogen molecule is very strong. Suggest an explanation.

.....
..... [2]

(d) Draw a diagram showing the arrangement of the outer shell (valency) electrons in a molecule of nitrogen.

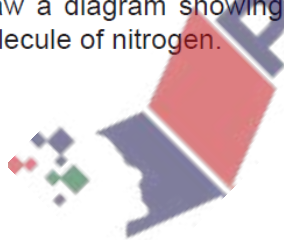

[2]

[Total: 7]

(b) Lithium reacts with nitrogen to form the ionic compound, lithium nitride.

(i) State the formula of the lithium ion. [1]

(ii) Deduce the formula of the nitride ion. [1]

(iii) In all solid ionic compounds, the ions are held together in a lattice.
Explain the term *lattice*.

.....
..... [1]

(iv) What is the ratio of lithium ions to nitride ions in the lattice of lithium nitride?
Give a reason for your answer.

..... lithium ions : nitride ions
.....
..... [2]

0620/s12/qp31

7 Chlorine reacts with phosphorus to form phosphorus trichloride.

(a) Draw a diagram showing the arrangement of the **valency** electrons in one molecule of the covalent compound, phosphorus trichloride.

Use x to represent an electron from a phosphorus atom.

Use o to represent an electron from a chlorine atom.



[2]

0620/s11/qp32

1 Choose an element from the list below which best fits the description.

Rb **Fe** **Si** **I** **P** **Sr**

- (a) An element which reacts with cold water. [1]
- (b) It is a solid at room temperature and exists as diatomic molecules, X_2 [1]
- (c) It can form two oxides, XO and X_2O_3 [1]
- (d) This element has a hydride of the type XH_3 [1]
- (e) It has a macromolecular structure similar to that of carbon. [1]

[Total: 5]

0620/s11/qp32

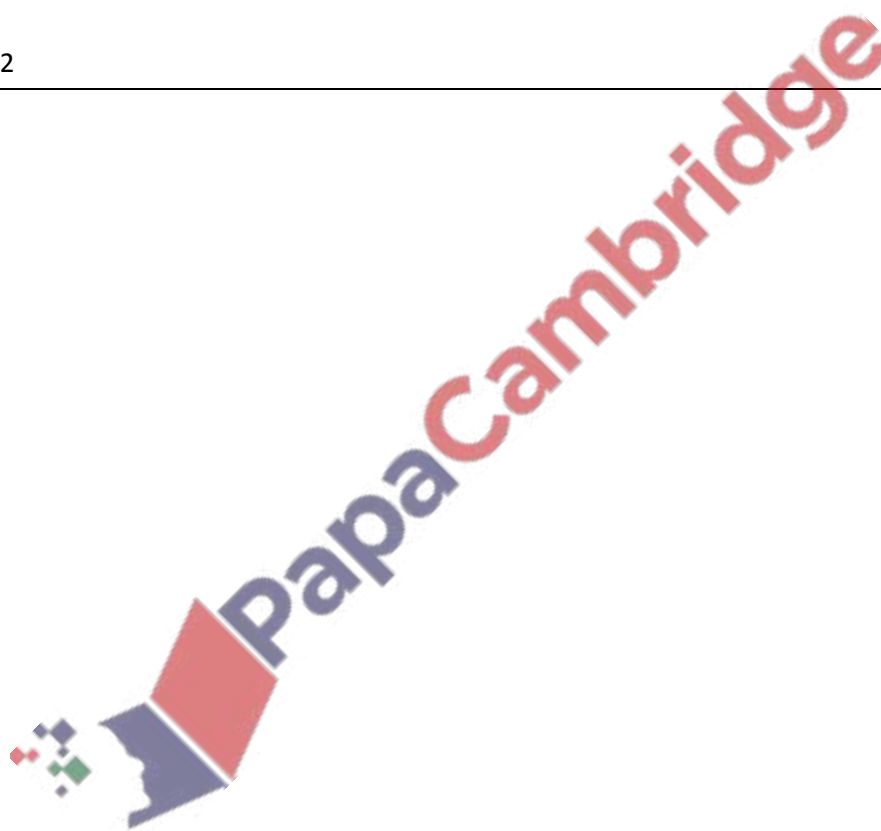

3 The following is a list of the electron distributions of atoms of unknown elements.

element	electron distribution
A	2,5
B	2,8,4
C	2,8,8,2
D	2,8,18,8
E	2,8,18,8,1
F	2,8,18,18,7

(a) Choose an element from the list for each of the following descriptions.

- (i) It is a noble gas.
- (ii) It is a soft metal with a low density.
- (iii) It can form a covalent compound with element A.
- (iv) It has a giant covalent structure similar to diamond.
- (v) It can form a negative ion of the type X^{3-} [5]

(b) Elements C and F can form an ionic compound.

- (i) Draw a diagram that shows the formula of this compound, the charges on the ions and the arrangement of the valency electrons around the negative ion.
Use **o** to represent an electron from an atom of C.
Use **x** to represent an electron from an atom of F.



[3]

- (ii) Predict **two** properties of this compound.

.....

.....

..... [2]

[Total: 10]

(c) Carbonyl chloride reacts with water to form two acidic compounds.
Suggest which acidic compounds are formed.

1.
2. [2]

(d) The structural formula of carbonyl chloride is given below.

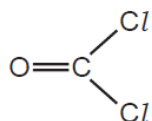

Draw a diagram that shows the arrangement of the valency electrons in one molecule of this covalent compound.

Use x for an electron from a chlorine atom.

Use o for an electron from a carbon atom.

Use • for an electron from an oxygen atom.

[4]

0620/s08/qp31

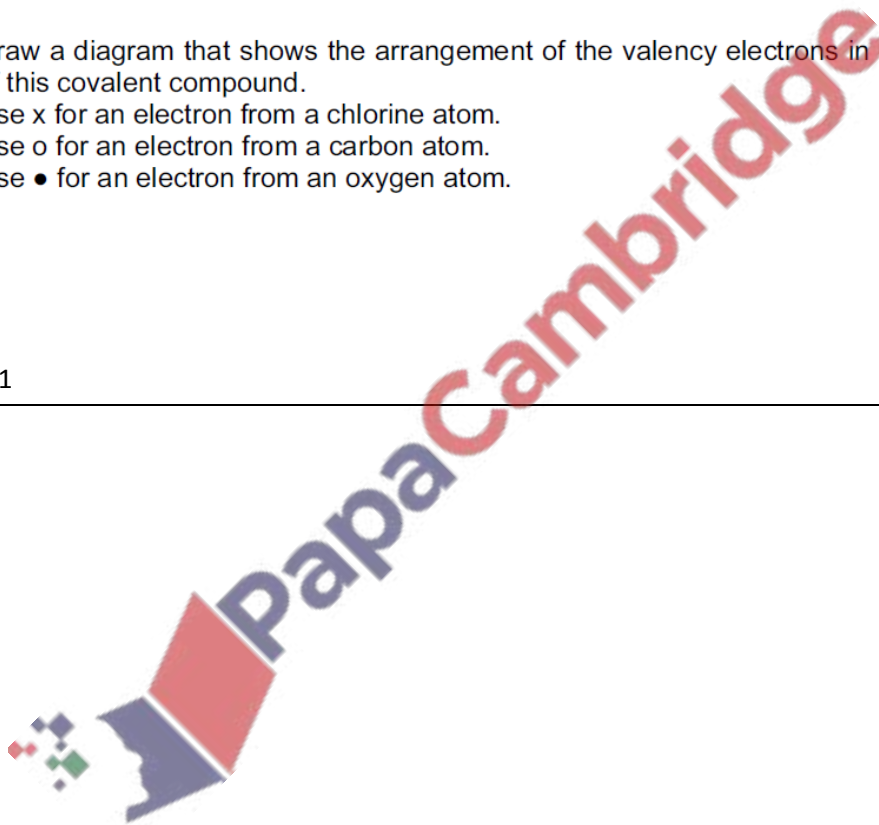

4 Use your copy of the periodic table to help you answer these questions.

(a) Predict the formula of each of the following compounds.

(i) barium oxide [1]

(ii) boron oxide [1]

(b) Give the formula of the following ions.

(i) sulphide [1]

(ii) gallium [1]

(c) Draw a diagram showing the arrangement of the valency electrons in one molecule of the covalent compound nitrogen trichloride.

Use x to represent an electron from a nitrogen atom.
Use o to represent an electron from a chlorine atom. [3]

(d) Potassium and vanadium are elements in Period IV.

(i) State **two** differences in their physical properties.

.....
..... [2]

(ii) Give **two** differences in their chemical properties.

.....
..... [2]

2 Complete the following table.

type of structure	particles present	electrical conductivity of solid	electrical conductivity of liquid	example
ionic	positive and negative ions	poor
macro molecular	atoms of two different elements in a giant covalent structure	poor	poor
metallic and	good	copper

[Total: 6]

0620/s07/qp3



4 The first three elements in Group IV are
carbon,
silicon,
germanium.

(a) The element germanium has a diamond-type structure. Describe the structure of germanium. A diagram is acceptable.

[2]

(b) Unlike diamond, graphite is soft and is a good conductor of electricity.

(i) Explain why graphite has these properties.

.....
.....
..... [3]

(ii) Give a use of graphite that depends on one of these properties.

property

use [1]

(c) Carbon dioxide and silicon(IV) oxide have similar formulae but different types of structure.

(i) Give the formulae of these oxides.

..... [1]

(ii) How are their structures different?

.....
..... [2]

(d) All these elements form compounds with hydrogen called hydrides. The saturated hydrides of carbon are the alkanes. Predict the formula of the hydride of germanium which contains two germanium atoms.

..... [1]

- (iii) Draw a diagram to show the arrangement of the valency electrons in one molecule of the covalent compound hydrogen sulphide.
Use o to represent an electron from a sulphur atom.
Use x to represent an electron from a hydrogen atom.

[2]

0620/s05/qp3

- 3 An organic compound decomposes to form nitrogen.

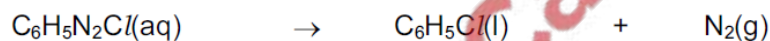

- (a) Explain the state symbols.

aq
l
g [2]

- (b) Draw a diagram to show the arrangement of the valency electrons in **one** molecule of nitrogen.

[2]

0620/s04/qp3

(iii) Describe the structure of silicon(IV) oxide. You may use a diagram.

..... [2]

0620/s04/qp3

(b) Silicon has the same type of macromolecular structure as diamond.

(i) Explain why one atom of either element can form four covalent bonds.

..... [2]

(ii) Predict **two** physical properties of silicon.

..... [2]

(iii) Name a different element that has a similar structure and properties to silicon.

..... [1]

0620/s04/qp3

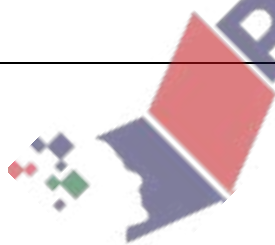

-
- (d) Barium chloride is an ionic compound. Draw a diagram that shows the formula of the compound, the charges on the ions and gives the arrangement of the valency electrons around the negative ion.

The electron distribution of a barium atom is 2.8.18.18.8.2

Use x to represent an electron from a barium atom.

Use o to represent an electron from a chlorine atom.

[2]

- (e) Describe, by means of a simple diagram, the lattice structure of an ionic compound, such as caesium chloride.

[2]

- (f) The reactions of these metals with oxygen are exothermic.

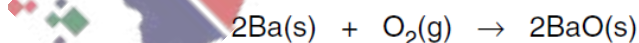

- (i) Give an example of bond forming in this reaction.

.....

0620/s03/qp3

- 2 Calcium and other minerals are essential for healthy teeth and bones. Tablets can be taken to provide these minerals.

Healthy Bones

Each tablet contains

calcium
magnesium
zinc
copper
boron

- (a) Boron is a non-metal with a macromolecular structure.
- (i) What is the valency of boron?
.....
- (ii) Predict **two** physical properties of boron.
.....
.....
- (iii) Name another element and a compound that have macromolecular structures.
element
compound
- (iv) Sketch the structure of one of the above macromolecular substances.

[7]

3 Magnesium reacts with bromine to form magnesium bromide.

(a) Magnesium bromide is an ionic compound. Draw a diagram that shows the formula of the compound, the charges on the ions and the arrangement of outer electrons around the negative ion.

The electron distribution of a bromine atom is 2, 8, 18, 7.

Use x to represent an electron from a magnesium atom.

Use o to represent an electron from a bromine atom.

[3]

(b) In the lattice of magnesium bromide, the ratio of magnesium ions to bromide ions is 1:2.

(i) Explain the term *lattice*.

.....
..... [2]

(ii) Explain why the ratio of ions is 1:2.

..... [1]

(iii) The reaction between magnesium and bromine is redox. Complete the sentences.

Magnesium is the agent because it has
..... electrons.

Bromine has been because it has
electrons. [4]

[Total: 10]

0620/w07/qp3

- (c) Two of the elements in chalcopyrite are the metal, copper, and the non-metal, sulphur. These have different properties. Copper is an excellent conductor of electricity and is malleable. Sulphur is a poor conductor and is not malleable, it is brittle. Explain, in terms of their structures, why this is so.

difference in electrical conductivity

.....
..... [2]

difference in malleability

.....
..... [2]

0620/w06/qp3

- (d) Give a diagram showing the arrangement of the valency electrons in one molecule of the covalent compound urea. Its structural formula is given below.

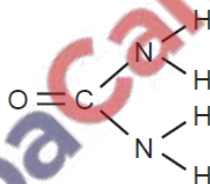

Use o to represent an electron from a carbon atom.
Use x to represent an electron from a hydrogen atom.
Use • to represent an electron from a nitrogen atom.

[3]

0620/w06/qp3

2 The table shows the melting points, boiling points and electrical properties of the six substances **A** to **F**.

substance	melting point / °C	boiling point / °C	electrical conductor at room temperature	electrical conductor of substance dissolved in water
A	961	2193	good	does not dissolve
B	113	444	does not conduct	does not dissolve
C	0	100	very poor	very poor
D	803	1465	does not conduct	good
E	-5 to -10	102 to 105	good	good
F	-85	-60	does not conduct	does not dissolve

(i) Which **three** substances are solids at room temperature?

..... [1]

(ii) Which **one** is an ionic compound?

..... [1]

(iii) Which **one** is a gas at room temperature?

..... [1]

(iv) Which **two** substances are liquids at room temperature?

..... [1]

(v) Which substance is a metal?

..... [1]

(vi) Which **one** is an impure substance?

..... [1]

0620/w06/qp3

- 1 (a) The structure of a typical ionic compound is a regular arrangement of positive and negative ions.

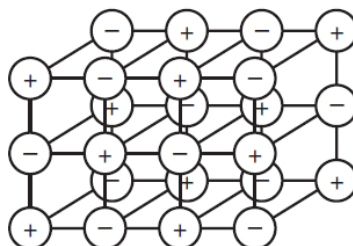

- (i) What is the name of this regular arrangement of particles?

..... [1]

- (ii) Give **two** physical properties of ionic compounds.

.....
..... [2]

- (b) Ions are formed by electron loss or gain. The electron distribution of a magnesium atom is $2 + 8 + 2$ and of a nitrogen atom is $2 + 5$.

- (i) Give the formula of the magnesium ion.

..... [1]

- (ii) Give the formula of the nitride ion.

..... [1]

- (iii) What is the formula of the ionic compound, magnesium nitride?

..... [1]

- (iv) In this compound there is an ionic bond. Why are the two ions attracted to each other?

..... [1]

0620/w05/qp3

- 5 Strontium and sulphur chlorides both have a formula of the type XCl_2 but they have different properties.

property	strontium chloride	sulphur chloride
appearance	white crystalline solid	red liquid
melting point / °C	873	-80
particles present	ions	molecules
electrical conductivity of solid	poor	poor
electrical conductivity of liquid	good	poor

- (a) The formulae of the chlorides are similar because both elements have a valency of 2. Explain why Group II and Group VI elements both have a valency of 2.

[2]

- (b) Draw a diagram showing the arrangement of the valency electrons in one covalent molecule of sulphur chloride.
Use x to represent an electron from a sulphur atom.
Use o to represent an electron from a chlorine atom.

[3]

- (c) Explain the difference in electrical conductivity between the following.

- (i) solid and liquid strontium chloride

[1]

- (ii) liquid strontium chloride and liquid sulphur chloride

[1]

(e) Another compound that contains nitrogen and hydrogen is hydrazine, N_2H_4 .

(i) Draw the structural formula of hydrazine. Hydrogen can form only one bond per atom but nitrogen can form three.

(ii) Draw a diagram that shows the arrangement of the valency electrons in one molecule of hydrazine. Hydrazine is a covalent compound.
Use x to represent an electron from a nitrogen atom.
Use o to represent an electron from a hydrogen atom.

[3]

0620/w03/qp3

(e) Draw a diagram that shows the arrangement of the valency electrons in the ionic compound sodium phosphide.

Use o to represent an electron from sodium.

Use x to represent an electron from phosphorus.

[3]

0620/w02/qp3

5 Carbon and silicon are elements in Group IV. Both elements have macromolecular structures.

(a) Diamond and graphite are two forms of the element carbon.

(i) Explain why diamond is a very hard substance.

.....
.....
..... [2]

(ii) Give **one** use of diamond.

..... [1]

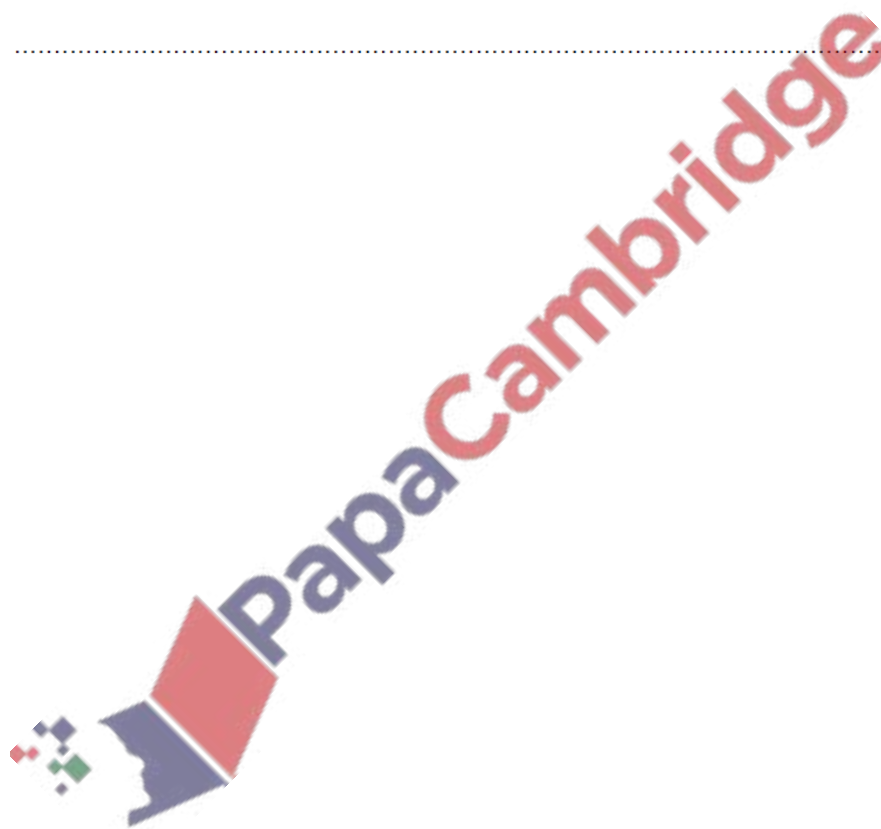

(iii) Explain why graphite is a soft material.

.....
..... [2]

(iv) Give **one** use of graphite.

..... [1]

(b) Two of the oxides of these elements are carbon dioxide, CO_2 , and silicon(IV) oxide, SiO_2 .

(i) Draw a diagram showing the arrangement of the valency electrons in one molecule of the covalent compound carbon dioxide.
Use x to represent an electron from a carbon atom.
Use o to represent an electron from an oxygen atom.

[3]

(ii) A section of the macromolecular structure of silicon(IV) oxide is given below.



Use this diagram to explain why the formula is SiO_2 not SiO_4 .

.....
..... [2]

(iii) Predict **two** differences in the physical properties of these two oxides.

.....
..... [2]

[Total: 13]

- (b) Scandium fluoride is an ionic compound. The valency of scandium in scandium fluoride is three.

Draw a diagram which shows the formula of this compound, the charges on the ions and the arrangement of the valency electrons around the negative ions.

Use \times to represent an electron from a fluorine atom.

Use \circ to represent an electron from a scandium atom.

[3]

- (c) The structural formula of carbonyl chloride is given below.

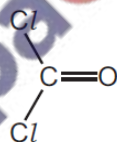

Draw a diagram showing the arrangement of the valency electrons around the atoms in one molecule of this covalent compound.

Use \circ to represent an electron from an oxygen atom.

Use \times to represent an electron from a chlorine atom.

Use \bullet to represent an electron from a carbon atom.

[3]

4 Germanium is an element in Group IV. The electron distribution of a germanium atom is $2 + 8 + 18 + 4$. It has oxidation states of +2 and +4.

(a) Germanium forms a series of saturated hydrides similar to the alkanes.

(i) Draw the structural formula of the hydride which contains three germanium atoms per molecule.

[1]

(ii) Predict the general formula of the germanium hydrides.

[1]

(b) Draw a diagram showing the arrangement of the valency electrons in one molecule of the covalent compound germanium(IV) chloride, GeCl_4 .

Use o to represent an electron from a chlorine atom.

Use x to represent an electron from a germanium atom.

[2]

(c) Describe the structure of the giant covalent compound germanium(IV) oxide, GeO_2 . It has a similar structure to that of silicon(IV) oxide.

[3]

0620/s13/qp33

(b) Predict the formula of each of the following compounds.

(i) germanium oxide

(ii) tellurium bromide [2]

(c) Give the formula of each of the following ions.

(i) strontium

(ii) fluoride [2]

0620/w11/qp33

(c) Draw a diagram showing the arrangement of the valency electrons in one molecule of the covalent compound methanol.

Use x to represent an electron from a carbon atom.

Use o to represent an electron from an oxygen atom.

Use • to represent an electron from a hydrogen atom.

[3]

0620/w11/qp32

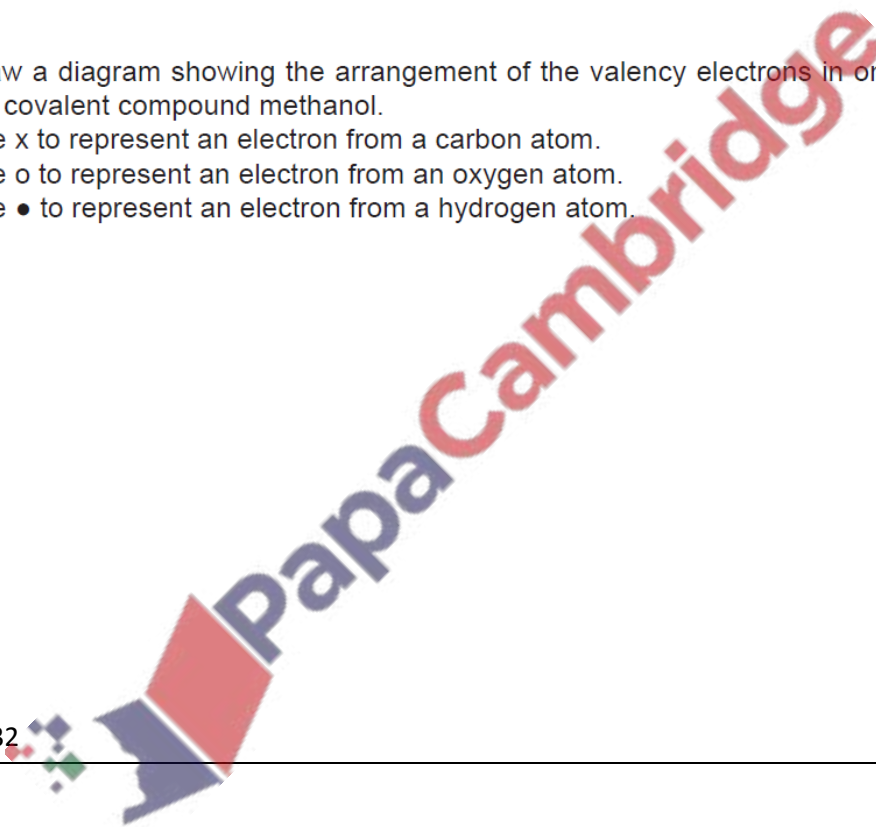

4 The structure of an element or compound determines its physical properties. Scandium fluoride and silicon(IV) oxide have giant structures.

(a) Scandium fluoride is an ionic compound.

(i) The valency of scandium is three. Draw a diagram which shows the formula of the compound, the charges on the ions and the arrangement of the valency electrons around the negative ion.

Use x to represent an electron from a scandium atom.

Use o to represent an electron from a fluorine atom.

[3]

(ii) The melting point of scandium fluoride is 1552 °C. Explain why scandium fluoride has a high melting point.

.....
..... [1]

(b) Silicon(IV) oxide has a macromolecular structure.

(i) Describe the structure of silicon(IV) oxide. You may use a diagram.



[3]

(ii) How does the electrical conductivity of these two compounds differ?

.....
..... [1]

(iii) Explain the difference in conductivity.

.....
..... [2]

[Total: 10]

- sulfur dioxide
- carbon monoxide
- lithium oxide
- aluminium oxide
- nitrogen dioxide
- strontium oxide

(c) Lithium oxide is an ionic compound.

(i) Identify another ionic oxide in the list on page 3.

..... [1]

(ii) Draw a diagram which shows the formula of lithium oxide, the charges on the ions and the arrangement of the valency electrons around the negative ion. Use x to represent an electron from an atom of oxygen. Use o to represent an electron from an atom of lithium.

[2]

(c) (i) Give the formulae of lithium fluoride and nitrogen fluoride.

lithium fluoride

nitrogen fluoride [2]

(ii) Predict **two** differences in their properties.

.....
..... [2]

(iii) Explain why these two fluorides have different properties.

.....
..... [2]

0620/w10/qp31

4 Ammonia is an important industrial chemical.

(a) (i) Give the electron structure of an atom of nitrogen.

..... [1]

(ii) Use this electronic structure, rather than the valency of nitrogen, to explain why the formula of ammonia is NH_3 not NH_4 .

.....
.....
..... [2]

0620/w10/qp31

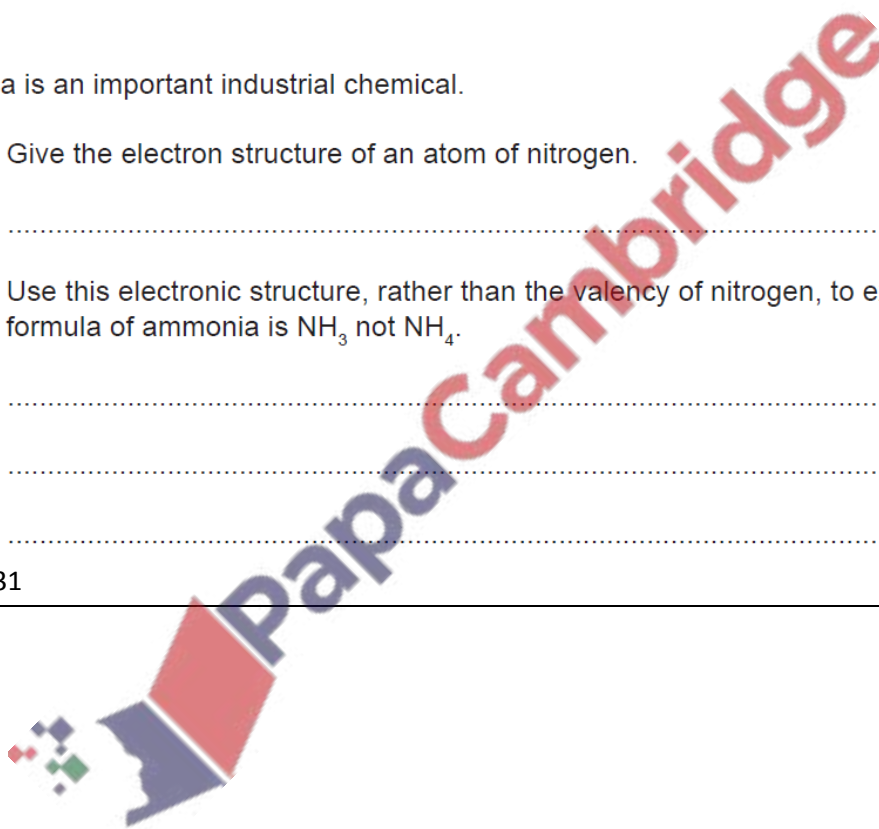

2 About 4000 years ago the Bronze Age started in Britain. Bronze is an alloy of copper and tin.

(a) (i) Suggest a reason why a bronze axe was better than a copper axe.

..... [1]

(ii) Brass is another copper alloy. Name the other metal in brass.

..... [1]

(b) The diagram below shows the arrangement of particles in a pure metal.

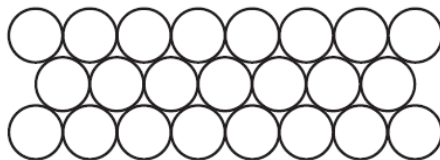

(i) What is the name given to a regular arrangement of particles in a crystalline solid?

..... [1]

(ii) Draw a diagram which shows the arrangement of particles in an alloy.

..... [2]

(iii) Explain the term *malleable*.

..... [1]

(iv) Why are metals malleable?

.....

..... [2]

0620/w10/qp31

1 The following table gives information about six substances.

substance	melting point / °C	boiling point / °C	electrical conductivity as a solid	electrical conductivity as a liquid
A	839	1484	good	good
B	-210	-196	poor	poor
C	776	1497	poor	good
D	-117	78	poor	poor
E	1607	2227	poor	poor
F	-5	102	poor	good

(a) Which substance could have a macromolecular structure, similar to that of silicon(IV) oxide?

..... [1]

(b) Which substances are solids at room temperature?

..... [1]

(c) Which substance could be a metal?

..... [1]

(d) Which substance could be aqueous sodium chloride?

..... [1]

(e) Which substance is an ionic compound?

..... [1]

(f) Which substances are liquids at room temperature?

..... [1]

[Total: 6]

0620/w10/qp32

-
- 6 The Kinetic Theory explains the properties of matter in terms of the arrangement and movement of particles.
- (a) Nitrogen is a gas at room temperature. Nitrogen molecules, N_2 , which are spread far apart move in a random manner at high speed.
- (i) Draw a diagram showing the arrangement of the valency electrons in a nitrogen molecule.
Use \times to represent an electron from a nitrogen atom.

[2]

0620/w10/qp33

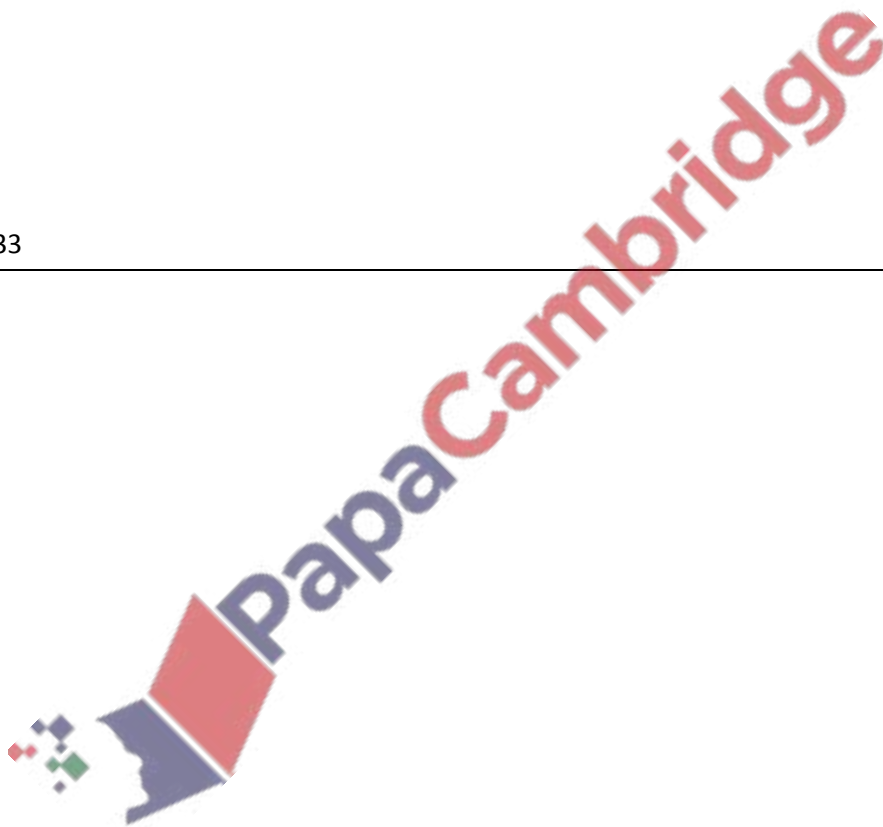

1 The diagrams below show the electron arrangement in two compounds.

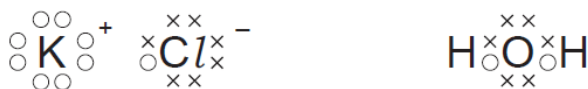

(a) In a water molecule, each hydrogen atom is bonded to the oxygen atom by sharing a pair of electrons.

Why does an oxygen atom share two pairs of electrons rather than just one pair?

.....
..... [1]

(b) Describe how a potassium atom becomes a potassium ion.

..... [1]

(c) Why is there a bond between the ions in potassium chloride?

.....
..... [1]

(d) Solid potassium chloride is a poor conductor of electricity. When dissolved in water it is a good conductor. Explain.

.....
..... [2]

[Total: 5]

5 The first three elements in Group IV are carbon, silicon and germanium. The elements and their compounds have similar properties.

(a) The compound, silicon carbide, has a macromolecular structure similar to that of diamond.

(i) A major use of silicon carbide is to reinforce aluminium alloys which are used in the construction of spacecraft. Suggest **three** of its physical properties.

.....
.....
..... [3]

(ii) Complete the following description of the structure of silicon carbide.

Each carbon atom is bonded to four atoms.

Each silicon atom is bonded to carbon atoms. [2]

(b) Germanium(IV) oxide, GeO_2 , has the same macromolecular structure as silicon(IV) oxide. Draw the structural formula of germanium(IV) oxide.

[3]

0620/w09/qp31



(c) It is now known that the smell of the seaside is due to the chemical dimethyl sulfide, $(\text{CH}_3)_2\text{S}$.

- (i) Draw a diagram that shows the arrangement of the valency electrons in one molecule of this covalent compound.
Use x to represent an electron from a carbon atom.
Use o to represent an electron from a hydrogen atom.
Use • to represent an electron from a sulfur atom.

(ii) Name the **three** compounds formed when dimethyl sulfide is burnt in excess oxygen. [3]

.....

.....

..... [2]

0620/w09/qp31



PapaCambridge

2 There are three types of giant structure – ionic, metallic and macromolecular.

(a) Sodium nitride is an ionic compound. Draw a diagram that shows the formula of the compound, the charges on the ions and the arrangement of the valency electrons around the negative ion.

Use x to represent an electron from a sodium atom.

Use o to represent an electron from a nitrogen atom.

[3]

(b) (i) Describe metallic bonding.

.....
..... [3]

(ii) Use the above ideas to explain why metals are good conductors of electricity,

..... [1]
metals are malleable.

..... [2]

(c) Silicon(IV) oxide has a macromolecular structure.

(i) **Describe** the structure of silicon(IV) oxide (a diagram is not acceptable).

.....
.....
..... [3]

(ii) Diamond has a similar structure and consequently similar properties. Give **two** physical properties common to both diamond and silicon(IV) oxide.

.....
..... [2]

[Total: 14]

Page 1	Page 2	Page 3	Page 4	Page 5	Page 6	Page 7	Page 8	Page 9	Page 10
8A	7C	6D	20A	6B	28C	8D	9C	29B	7C
7C	8C	7A	20B	6C	27D	7B	7A	11B	7B
6A	7B	6C	7A	4D	9D	30B	8B	9A	

page 11	page 12	page 13	page 14	page 15	page 16	page 17	page 18	page 19	page 20
8B	6A	9B	8D	7C	8C	11D	10D	8A	18B
6D	4C	7A	9A	26D	9A	7A	9A	21A	9C
	8C	27D		18C	10B	23A	7C		8D

page 21	page 22	page 23	page 24	page 25	page 26	page 27	page 28	page 29	page 30
6B	3C	7C	7A	10C	29C	10C	6A	7A	3B
4A	27B	8A	8D	8A	7C	9D	7D	26A	11B
	10D	9D			8B		8C	7C	

page 31	page 32	page 33	page 34	page 35	page 36
9B	8A	11C	6C	29A	9A
7A	7A	9D	6D	8C	6C
10D		8B			22C

