



Cambridge Pre-U

CANDIDATE
NAME

--

CENTRE
NUMBER

--	--	--	--	--

CANDIDATE
NUMBER

--	--	--	--



PHYSICS

9792/03

Paper 3 Written Paper

May/June 2023

3 hours

You must answer on the question paper.

No additional materials are needed.

INSTRUCTIONS

- Section 1: answer **all** questions.
- Section 2: answer **three** questions.
- Use a black or dark blue pen. You may use an HB pencil for any diagrams or graphs.
- Write your name, centre number and candidate number in the boxes at the top of the page.
- Write your answer to each question in the space provided.
- Do **not** use an erasable pen or correction fluid.
- Do **not** write on any bar codes.
- You may use a calculator.
- You should show all your working and use appropriate units.

INFORMATION

- The total mark for this paper is 140.
- The number of marks for each question or part question is shown in brackets [].

This syllabus is regulated for use in England, Wales and Northern Ireland as a Cambridge International Level 3 Pre-U Certificate.

This document has **44** pages. Any blank pages are indicated.

Data

gravitational field strength close to Earth's surface	$g = 9.81 \text{ N kg}^{-1}$
elementary charge	$e = 1.60 \times 10^{-19} \text{ C}$
speed of light in vacuum	$c = 3.00 \times 10^8 \text{ m s}^{-1}$
Planck constant	$h = 6.63 \times 10^{-34} \text{ J s}$
permittivity of free space	$\epsilon_0 = 8.85 \times 10^{-12} \text{ F m}^{-1}$
gravitational constant	$G = 6.67 \times 10^{-11} \text{ N m}^2 \text{ kg}^{-2}$
electron mass	$m_e = 9.11 \times 10^{-31} \text{ kg}$
proton mass	$m_p = 1.67 \times 10^{-27} \text{ kg}$
unified atomic mass constant	$u = 1.66 \times 10^{-27} \text{ kg}$
molar gas constant	$R = 8.31 \text{ J K}^{-1} \text{ mol}^{-1}$
Avogadro constant	$N_A = 6.02 \times 10^{23} \text{ mol}^{-1}$
Boltzmann constant	$k = 1.38 \times 10^{-23} \text{ J K}^{-1}$
Stefan-Boltzmann constant	$\sigma = 5.67 \times 10^{-8} \text{ W m}^{-2} \text{ K}^{-4}$

Formulae

uniformly accelerated motion	$s = ut + \frac{1}{2}at^2$	change of state	$\Delta E = mL$	
	$v^2 = u^2 + 2as$		refraction	$n = \frac{\sin\theta_1}{\sin\theta_2}$
	$s = \left(\frac{u+v}{2}\right)t$			$n = \frac{v_1}{v_2}$
heating	$\Delta E = mc\Delta\theta$			

diffraction		electromagnetic induction	$E = -\frac{d(N\Phi)}{dt}$
single slit, minima	$n\lambda = b \sin\theta$	Hall effect	$V = Bvd$
grating, maxima	$n\lambda = d \sin\theta$	time dilation	$t' = \frac{t}{\sqrt{1 - \frac{v^2}{c^2}}}$
double slit interference	$\lambda = \frac{ax}{D}$	length contraction	$l' = l\sqrt{1 - \frac{v^2}{c^2}}$
Rayleigh criterion	$\theta \approx \frac{\lambda}{b}$	kinetic theory	$\frac{1}{2}m\langle c^2 \rangle = \frac{3}{2}kT$
photon energy	$E = hf$	work done on/by a gas	$W = p\Delta V$
de Broglie wavelength	$\lambda = \frac{h}{p}$	radioactive decay	$\frac{dN}{dt} = -\lambda N$ $N = N_0 e^{-\lambda t}$ $t_{\frac{1}{2}} = \frac{\ln 2}{\lambda}$
simple harmonic motion	$x = A \cos \omega t$ $v = -A\omega \sin \omega t$ $a = -A\omega^2 \cos \omega t$ $F = -m\omega^2 x$ $E = \frac{1}{2}mA^2\omega^2$	attenuation losses	$I = I_0 e^{-\mu x}$
energy stored in a capacitor	$W = \frac{1}{2}QV$	mass-energy equivalence	$\Delta E = c^2\Delta m$
capacitor discharge	$Q = Q_0 e^{-\frac{t}{RC}}$	hydrogen energy levels	$E_n = \frac{-13.6\text{eV}}{n^2}$
electric force	$F = \frac{Q_1 Q_2}{4\pi\epsilon_0 r^2}$	Heisenberg uncertainty principle	$\Delta p \Delta x \geq \frac{h}{2\pi}$
electrostatic potential energy	$W = \frac{Q_1 Q_2}{4\pi\epsilon_0 r}$	Wien's displacement law	$\lambda_{\max} \propto \frac{1}{T}$
gravitational force	$F = -\frac{Gm_1 m_2}{r^2}$	Stefan's law	$L = 4\pi\sigma r^2 T^4$
gravitational potential energy	$E = -\frac{Gm_1 m_2}{r}$	electromagnetic radiation from a moving source	$\frac{\Delta\lambda}{\lambda} \approx \frac{\Delta f}{f} \approx \frac{v}{c}$
magnetic force	$F = BIl \sin\theta$ $F = BQv \sin\theta$		

Section 1

Answer **all** questions in this section.

You are advised to spend about 1 hour 30 minutes on this section.

- 1 A particle of point mass m is moving at constant speed v in a circular path, as shown in Fig. 1.1.

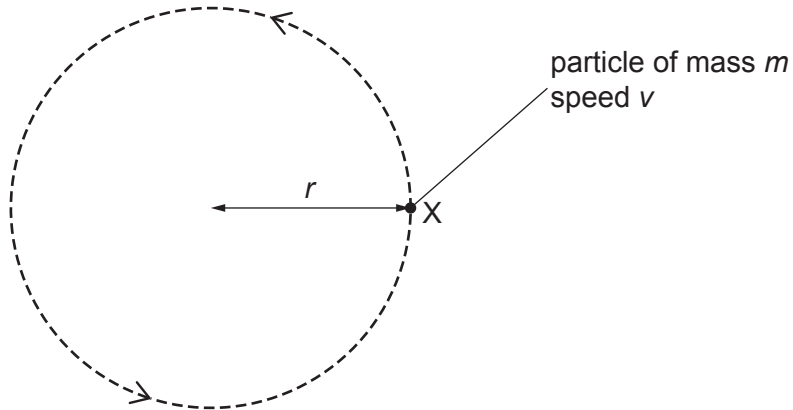

Fig. 1.1

The particle is shown at an instant when it is in position X.

- (a) (i) Define the radian.

.....
 [1]

- (ii) On Fig. 1.1, draw an arrow to indicate the velocity of the particle in position X. [1]

- (b) A short time later, the particle has moved through an angle θ around the circle to position Y, as shown in Fig. 1.2.

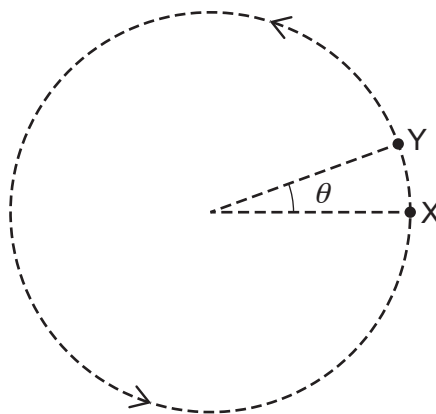

Fig. 1.2

- (i) Deduce an expression, in terms of r , v and θ , for the time t taken for the particle to move from position X to position Y.

[2]

- (ii) There is a change in velocity Δv as the particle accelerates from velocity v_x at point X to velocity v_y at point Y.

Complete the vector diagram in Fig. 1.3 to show this change by adding an arrow and a label to each side of the triangle.



Fig. 1.3

[1]

- (iii) Use your answers in (b)(i) and (b)(ii) to deduce the expression for the centripetal acceleration a of the particle in terms of v and r . Explain your reasoning.

[3]

- (c) The Earth has a radius of 6.4×10^6 m.

Determine the centripetal acceleration, due to the rotation of the Earth, of a particle at the Equator.

centripetal acceleration = ms^{-2} [2]

[Total: 10]

- 2 A student investigates the relationship between the energy E stored in a capacitor and the potential difference (p.d.) V across its plates. The student is testing the theoretical relationship

$$E = kV^2$$

where k is a constant.

The student carries out the following procedure:

- The capacitor is charged, using a variable p.d. supply, and then placed in the circuit shown in Fig. 2.1.

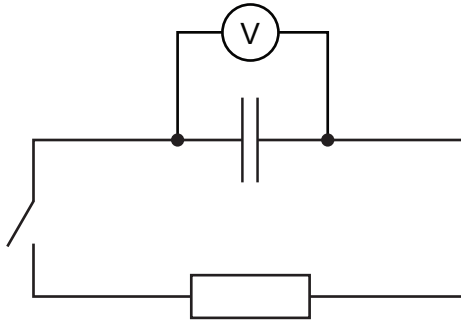

Fig. 2.1

- The switch is initially open. The p.d. V across the capacitor is measured.
- The resistor is immersed in a small tube containing water and the initial temperature θ_1 of the water is measured. The switch is then closed and the final temperature θ_2 of the water is measured when the temperature stops rising.

This procedure is repeated using different values of V and the results are compared.

- (a) State **two** physical quantities that the student must ensure remain constant for each repetition of the procedure for the investigation to be a fair test of the relationship.

1

2

[2]

- (b) State **two** precautions that the student should take to obtain accurate results.

1

.....

2

.....

[2]

(c) Table 2.1 shows the results obtained by the student.

Table 2.1

V/V	$\theta_1 / ^\circ\text{C}$	$\theta_2 / ^\circ\text{C}$
240	21.1	21.4
460	21.6	22.8
840	23.2	27.3

Determine whether or not the results in Table 2.1 support the relationship being tested. Give a reason for your answer.

.....

 [2]

- (d) (i) The specific heat capacity of water is $4.20 \text{ J g}^{-1} \text{ K}^{-1}$.
 The mass of water in the tube is measured to be 12.3 g.

Use the data in the last row of Table 2.1 to determine a value for k . Give a unit with your answer.

$k = \dots\dots\dots$ unit $\dots\dots\dots$ [3]

(ii) Use your answer in (d)(i) to determine a value for the capacitance C of the capacitor.

$C = \dots\dots\dots$ F [1]

(e) State **three** further improvements that the student could make to the experiment for it to more strongly support a conclusion about the relationship being tested.

1

.....

2

.....

3

.....

[3]

[Total: 13]

- 3 A trolley of mass m on frictionless rails is attached to two springs, each of spring constant k . The other ends of the springs are connected to fixed blocks, as shown in Fig. 3.1.

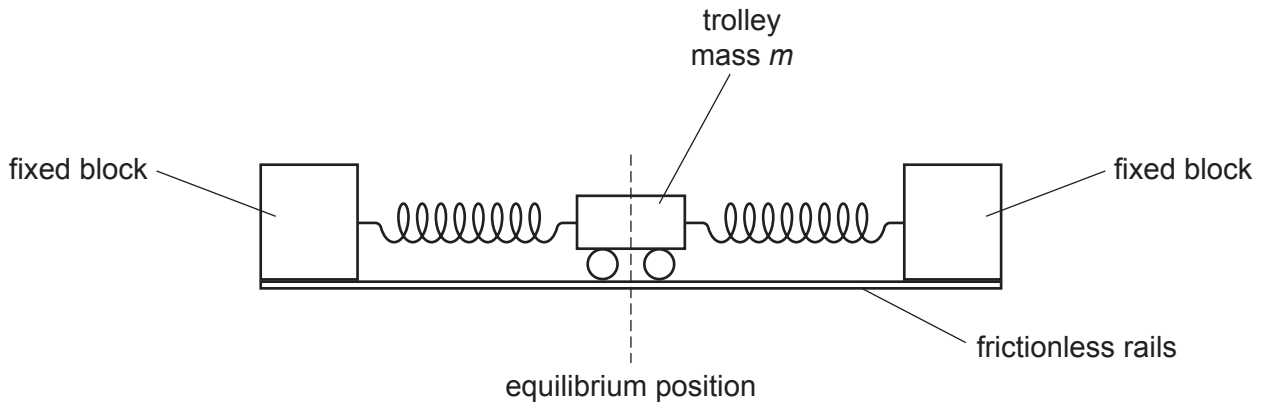

Fig. 3.1

The trolley is displaced horizontally from its equilibrium position and then released so that it oscillates. Both springs remain within the limit of proportionality throughout the oscillation.

- (a) (i) Show that, when the displacement of the trolley from its equilibrium position is $+x$, it experiences a restoring force F from the springs given by

$$F = -2kx .$$

[2]

- (ii) Use the equation in (a)(i) to show that the oscillations of the trolley are simple harmonic with period T given by

$$T = \pi \sqrt{\frac{2m}{k}} .$$

[2]

- (b) A rectangular piece of card is now attached to the top of the trolley so that the trolley now experiences a resistive force.

The trolley is again displaced from its equilibrium position and released so that it oscillates. Fig. 3.2 shows the variation with time t of the displacement x of the trolley from the equilibrium position.

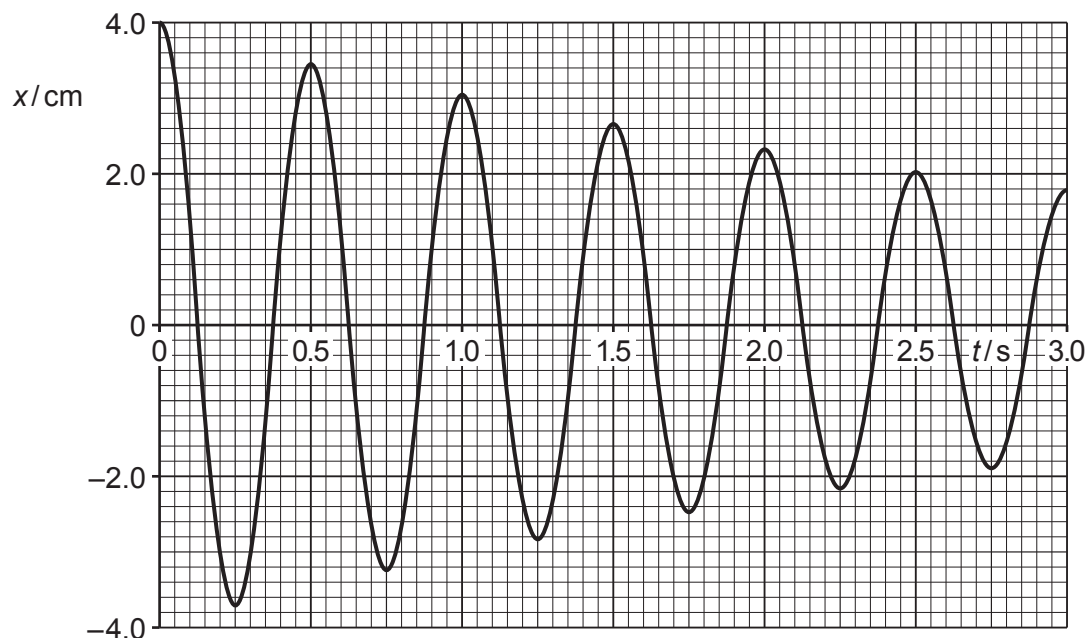

Fig. 3.2

- (i) State the name of the phenomenon demonstrated in Fig. 3.2.

..... [1]

- (ii) By reading the appropriate values from Fig. 3.2, complete the second column of Table 3.1 to show the amplitude x_0 of the oscillations at the end of each full oscillation.

Table 3.1

t/s	x_0/cm	$\ln\left(\frac{x_0}{4.00\text{ cm}}\right)$
0.00	4.00	0.000
0.50		
1.00		
1.50		
2.00		
2.50		
3.00		

[2]

- (iii) For each value of x_0 in Table 3.1, calculate $\ln\left(\frac{x_0}{4.00\text{ cm}}\right)$ and enter the value into the final column of the table. [1]

- (c) (i) On Fig. 3.3, plot a graph of $\ln\left(\frac{x_0}{4.00\text{ cm}}\right)$ against t using the data in Table 3.1. Include the straight line of best-fit.

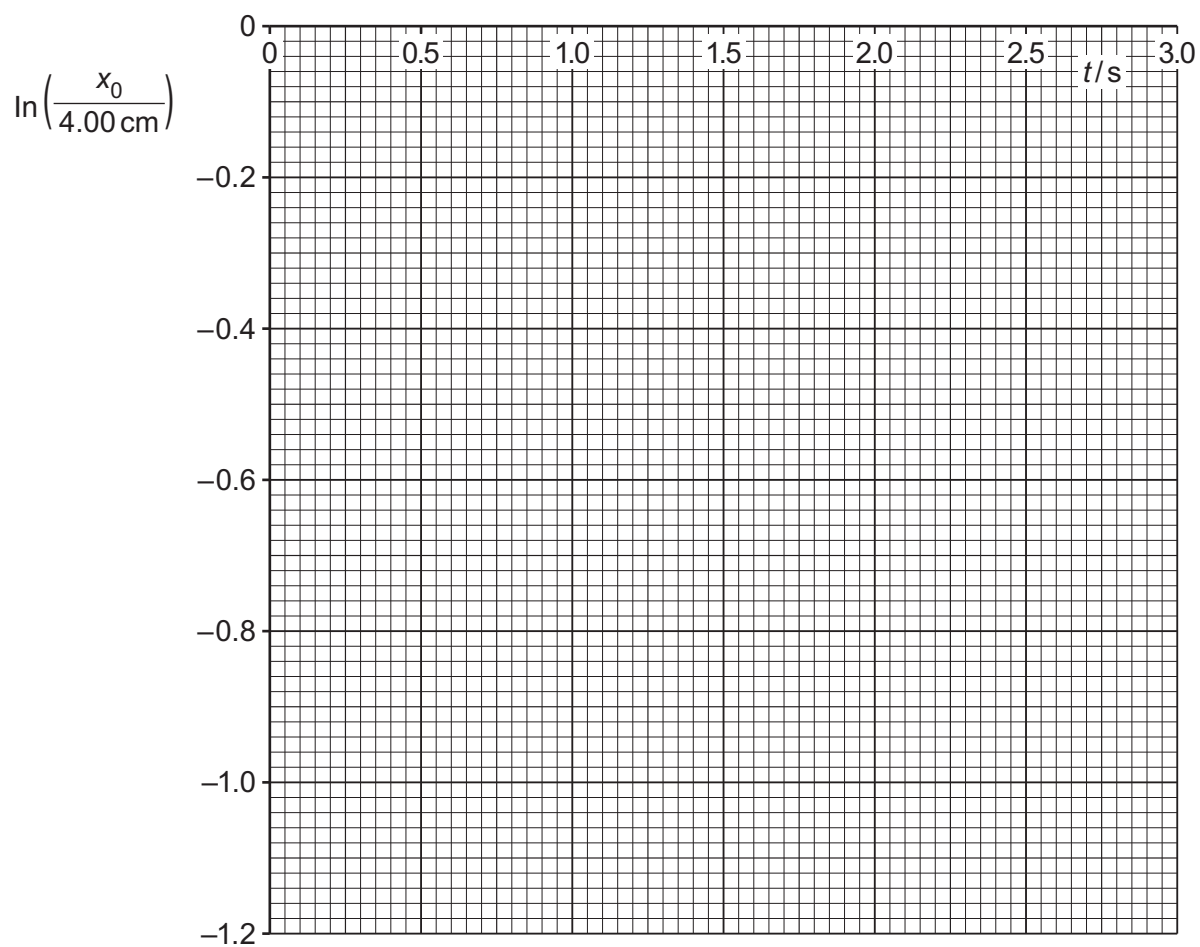

Fig. 3.3

[3]

- (ii) Determine the gradient of your line in (c)(i).

gradient = [1]

(d) Theory suggests that the variation of x_0 with t is given by

$$x_0 = 4.00 e^{-\frac{Rt}{4m}}$$

where x_0 is in cm and R is a constant that depends on the area of the card.

The mass m of the trolley is 0.170 kg.

Use your answer in (c)(ii) to determine a value for R . Give a unit with your answer.

$R = \dots\dots\dots$ unit $\dots\dots\dots$ [3]

(e) Theory also suggests that the period T of the oscillations, when the card is attached, is given by

$$T = 4\pi m \sqrt{\frac{1}{8mk - R^2}}$$

Suggest the significance of R becoming sufficiently large that $R^2 > 8mk$.

.....
 [1]

[Total: 16]

- 4 (a) State **one** similarity and **one** difference between the electric field due to a point charge and the gravitational field due to a point mass.

similarity

.....

difference

.....

[2]

- (b) Calculate, to three significant figures, the ratio

$$\frac{\text{gravitational force}}{\text{electric force}}$$

for the forces between the electron and the proton in a hydrogen atom.

ratio = [3]

- (c) (i) The ratio calculated in (b) is also the ratio

$$\frac{\text{gravitational potential energy}}{\text{electric potential energy}}$$

for the electron in a hydrogen atom.

Determine the electric potential energy of the electron in a hydrogen atom when the distance of separation between the electron and the proton is 5.00×10^{-11} m.

electric potential energy = J [3]

- (ii) Use your answer in (c)(i) to determine the speed that an electron would need to have in order to escape from the electric forces of attraction in a hydrogen atom.

escape speed = ms^{-1} [2]

[Total: 10]

- 5 (a) Helium atoms have a mass of 6.68×10^{-27} kg. Helium may be considered as an ideal gas.
- (i) Determine the root-mean-square (r.m.s.) speed of helium atoms in helium gas at 25°C .

r.m.s. speed = ms^{-1} [3]

- (ii) Show that the total kinetic energy of all the helium atoms in 1.00 mol of helium gas at 25°C is 3710 J.

[2]

- (iii) Explain why the energy in (a)(ii) is also the internal energy of 1.00 mol of helium gas at 25°C .

.....
.....
..... [2]

(b) The ideal gas in (a) is gradually cooled from 25 °C to -269 °C.

On Fig. 5.1, sketch the variation with temperature θ of the internal energy U of the gas.

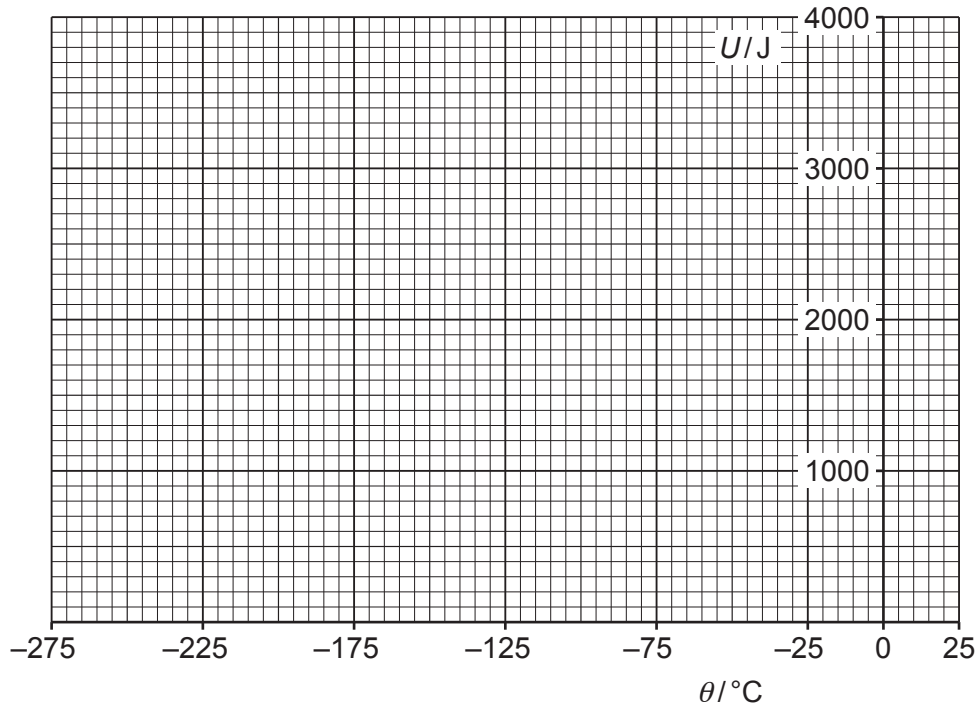

Fig. 5.1

[2]

(c) Use the assumptions of the kinetic theory to suggest an explanation for why helium ceases to behave as an ideal gas at temperatures below -269 °C.

.....

.....

..... [2]

[Total: 11]

- 6 (a) (i) On Fig. 6.1, sketch the variation of binding energy per nucleon with nucleon number A , for values of A up to 240.

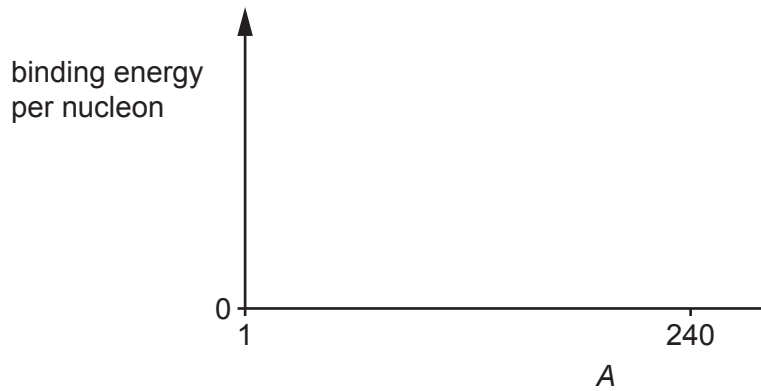

Fig. 6.1

[2]

- (ii) Use your answer in (a)(i) to explain why the processes of nuclear fusion and nuclear fission both result in the release of energy.

.....

.....

.....

.....

.....

..... [3]

(b) The nuclear fission of uranium-235 can be described by

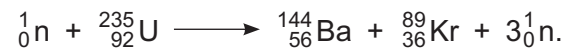

Table 6.1 shows the masses of the particles involved in this reaction.

Table 6.1

particle	mass/u
${}_0^1\text{n}$	1.008665
${}_{36}^{89}\text{Kr}$	88.917636
${}_{56}^{144}\text{Ba}$	143.922953
${}_{92}^{235}\text{U}$	235.043930

Determine the energy released by the fission of 15.0 kg of uranium-235.

energy = J [4]

[Total: 9]

- 7 (a) Fig. 7.1 shows a vertical line that corresponds to the lowest frequency in the Balmer series in the emission spectrum of hydrogen.



Fig. 7.1

- (i) On Fig. 7.1, draw the next three lines in the Balmer series. [1]
- (ii) Show that the photon energy that corresponds to the lowest frequency line in the Balmer series is $3.02 \times 10^{-19} \text{ J}$.

[3]

- (iii) Calculate the wavelength of the lowest frequency line in the Balmer series.

wavelength = m [2]

- (b) The emission spectrum of hydrogen is analysed in light from a distant galaxy that is 1.2×10^{25} m from the Earth.

The Hubble constant may be taken as $2.3 \times 10^{-18} \text{ s}^{-1}$.

- (i) Calculate the speed of recession of the galaxy from the Earth.

speed = ms^{-1} [2]

- (ii) Explain why the wavelength λ_0 of the lowest frequency line in the Balmer series, observed in the light from the galaxy, is different from your answer in (a)(iii).

.....
 [1]

- (iii) Determine the value of λ_0 .

$\lambda_0 = \dots\dots\dots$ m [2]

[Total: 11]

Section 2

Answer any **three** questions in this section.
 You are advised to spend about 1 hour 30 minutes on this section.

- 8 (a) Fig. 8.1 shows two flywheels mounted on frictionless bearings.

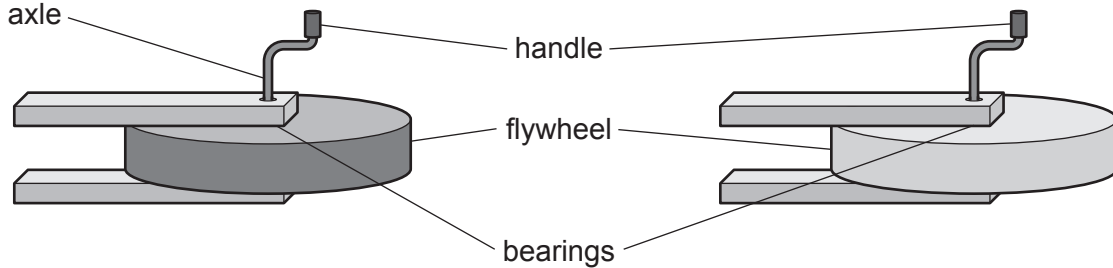

Fig. 8.1

The flywheels have different moments of inertia about their axles. Each flywheel has an identical handle.

A student is blindfolded and asked to decide, by turning the handles, which flywheel has the greater moment of inertia.

State **two** ways that the student can determine which flywheel has the greater moment of inertia.

- 1
-
- 2
-

[2]

- (b) (i) A rotating wheel has an angular acceleration α .

By analogy with Newton's laws for linear motion, suggest what is meant by angular acceleration.

.....

..... [1]

- (ii) A cyclist accelerates uniformly from a speed of 2.5 m s^{-1} to 8.0 m s^{-1} in a time of 36 s. The outer radius of a wheel on the bicycle is 0.350 m.

Calculate the angular acceleration of this wheel.

angular acceleration = rad s^{-2} [3]

(c) A cyclist is riding along a road at a constant speed of 12.0 m s^{-1} .

(i) The bicycle's wheels are each of radius 0.350 m and moment of inertia 0.200 kg m^2 .

Calculate the rotational kinetic energy of one wheel.

rotational kinetic energy = J [3]

(ii) The combined mass of cyclist and bicycle is 75.0 kg .

Calculate the linear kinetic energy of the cyclist and bicycle.

linear kinetic energy = J [1]

(d) Use integration to show that the moment of inertia about an axle I of a uniform disc of mass M and radius r is given by

$$I = \frac{1}{2} Mr^2.$$

[3]

- (e) Fig. 8.2 shows a disc of radius 0.150 m and mass 0.120 kg that is free to roll on an axle between two rails. The axle attached to the disc has radius 0.0050 m and has negligible mass.

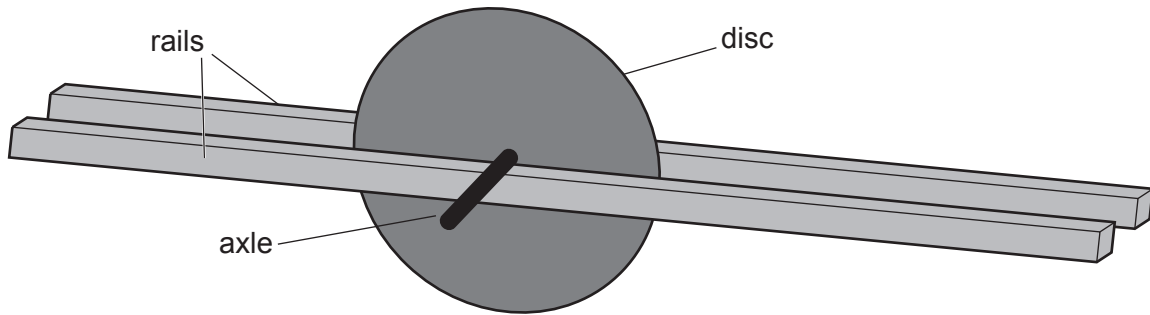

Fig. 8.2

The rails are inclined at an angle of 5.0° to the horizontal.

- (i) Assume that the frictional force between the axle and the rails is zero so that the disc can slide down the rails without rotating. The disc is released from rest.

Calculate the time the disc takes to travel 1.50 m along the rails from its release point.

time = s [3]

- (ii) There is now a frictional force between the axle and the rails so that the disc rolls without sliding. No energy is dissipated as the disc rolls. The disc is released from rest.

Calculate the time taken for the disc to travel 1.50 m along the rails from its release point.

time = s [4]

[Total: 20]

- 9 Coulomb's Law states the magnitude of the force between two point charges Q_1 and Q_2 at a distance r apart is

$$F = k \frac{Q_1 Q_2}{r^2} .$$

The constant $k = \frac{1}{4\pi\epsilon_0} = 8.99 \times 10^9 \text{ m F}^{-1}$.

- (a) (i) Use Coulomb's law and integration to show that the equation for the electrostatic potential energy E stored between point charges, Q_1 and Q_2 , at a distance r apart is given by

$$E = k \frac{Q_1 Q_2}{r} .$$

[3]

- (ii) Calculate the electrostatic potential energy of an electron 0.30 nm from an isolated proton.

electrostatic potential energy = J [1]

- (b) A simple model of an atom consists of an electron trapped in a one-dimensional potential well of width 0.80 nm, as shown in Fig. 9.1.

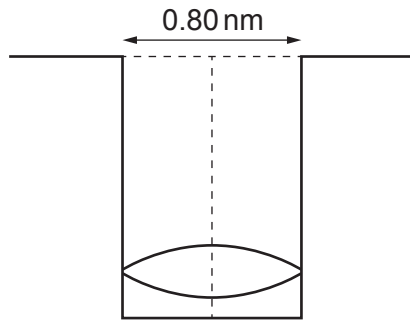

Fig. 9.1

The standing wave of an electron is shown in the potential well.

- (i) Calculate the momentum of the electron.

momentum = kg m s^{-1} [2]

- (ii) Calculate the kinetic energy of the electron. Give your answer in electronvolts.

kinetic energy = eV [3]

- (iii) Determine what happens to the kinetic energy of the electron if the width of the potential well is reduced to 0.10 nm.

..... [1]

- (c) There is a more advanced model of the hydrogen atom than the simple model of an atom in (b). The model consists of an electron orbiting a much heavier proton at a constant distance r . The electron has mass m , speed v and charge e .

- (i) Explain how this more advanced model leads to the equation

$$\frac{mv^2}{r} = \frac{e^2}{4\pi\epsilon_0 r^2}.$$

.....

 [2]

- (ii) Niels Bohr suggested that the angular momentum L of an orbiting electron is quantised and given by the formula

$$L = n \frac{h}{2\pi}$$

where n is an integer and h is the Planck constant. The angular momentum is the product of the moment of inertia and the angular velocity.

Show that an expression for the angular momentum of an electron in terms of m , v and r is

$$L = mvr.$$

[1]

- (iii) Use the three equations from (c)(i) and (c)(ii) to show the radius of the orbit is given by the equation

$$r = n^2 \frac{h^2 \epsilon_0}{\pi m e^2}.$$

[3]

- (iv) The total energy of a body orbiting a much heavier body is equal to half the potential energy. This is true for planets orbiting the Sun as well as an electron orbiting a proton. Use the equation in (c)(iii) to show that the total energy of an orbiting electron is

$$E = -\frac{1}{n^2} \left(\frac{me^4}{8\epsilon_0^2 h^2} \right).$$

[2]

- (v) Calculate the energy of the energy state when $n = 1$.

energy = J [2]

[Total: 20]

10 Michael Faraday had a visual approach to physics and developed the idea of field lines. James Clerk Maxwell summarised Faraday’s ideas in four equations.

(a) Fig. 10.1 shows the **magnetic** field near a wire that is carrying a current into the page. Fig. 10.2 shows the **electric** field around a positive charge.

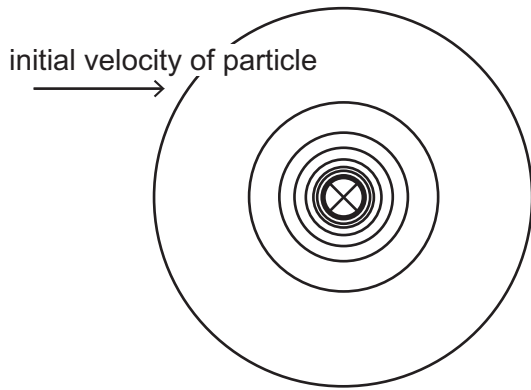

Fig. 10.1

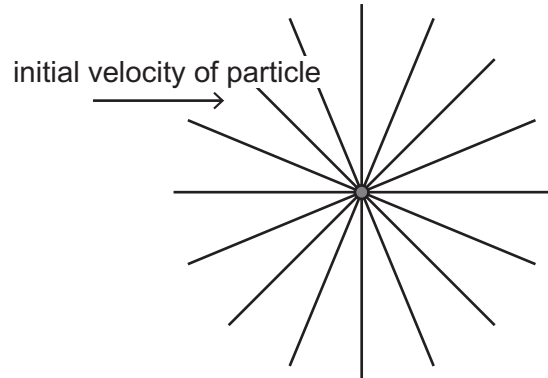

Fig. 10.2

A positively charged particle is shown entering each field. The directions of the field lines are not shown.

(i) On Fig. 10.1 and Fig. 10.2, clearly indicate the direction of the fields. [1]

(ii) The arrows show the initial directions of the positively charged particles as they move into each field.

Compare the direction of the force on the charged particle in the magnetic field with the direction of the force on the charged particle in the electric field.

.....

.....

..... [1]

- (b) A parallel-plate capacitor of capacitance C consists of two square plates of area A with an air gap z between them. The gap is very much smaller than each side length of the square plates. Fig. 10.3 shows the electric field between the plates.

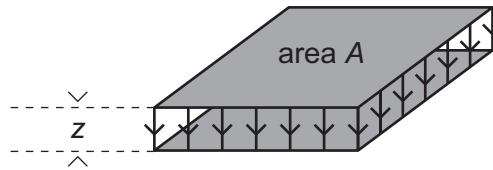

Fig. 10.3 (not to scale)

- (i) Define capacitance for a parallel-plate capacitor.

.....
 [2]

- (ii) The first of Maxwell's four equations states that the electric flux leaving any closed surface is equal to $\frac{q}{\epsilon_0}$, where q is the charge inside the closed surface and ϵ_0 is the permittivity of free space. As in magnetism, the flux density equals the field strength.

Explain why the electric field strength between the two plates of the capacitor is equal to

$$\frac{q}{\epsilon_0 A}$$

.....
 [1]

- (iii) Show that the capacitance C is given by

$$C = \frac{\epsilon_0 A}{z}$$

[2]

- (iv) The area A is 0.0200 m^2 and the distance z is 0.500 mm .

Calculate the capacitance C in pF.

$C = \dots\dots\dots$ pF [1]

- (c) Maxwell's equations describe the electromagnetic field and predict the existence of electromagnetic waves.

State what is predicted about the speed of these waves.

..... [1]

- (d) A parallel-plate capacitor consists of two very long rectangular strips as shown in Fig. 10.4.

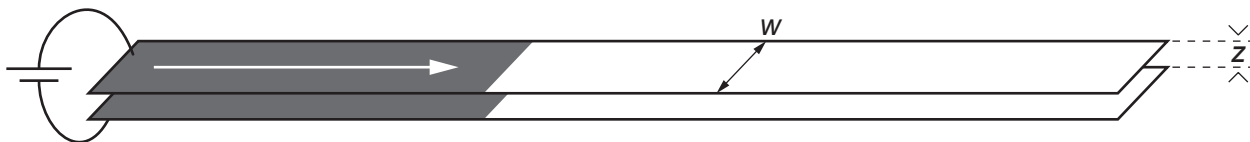

Fig. 10.4 (not to scale)

The width of the strips is w and the gap between the strips is z . When a battery is connected at the left-hand end, the plates do **not** charge instantly. The area that is already charged is shown in grey. The current in the top plate is shown with a white arrow. The current in the lower plate is in the opposite direction. The voltage between the charged area of the plates is V .

Fig. 10.5 shows the plates a time t later when an extra length x has become charged.

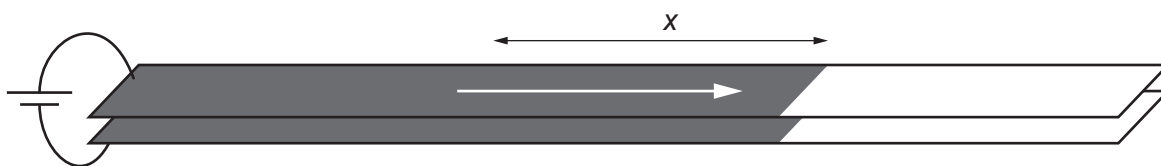

Fig. 10.5 (not to scale)

- (i) By considering the extra area charged in Fig. 10.5, show that the current in the cell is given by the formula

$$I = \frac{\epsilon_0 x w V}{z t}.$$

[2]

- (ii) Show that the speed v that the edge of the charged area is moving is given by

$$v = \frac{I z}{V w \epsilon_0}.$$

[2]

- (iii) The second of Maxwell's equations concerns magnetic fields. From this equation, it can be deduced that the magnetic field strength B between the shaded plates is given by the equation

$$B = \frac{\mu_0 I}{w}.$$

The constant $\mu_0 = 1.26 \times 10^{-6} \Omega \text{ s m}^{-1}$.

Show that the change in magnetic flux $\Delta\Phi$ linked with the circuit in time t is

$$\Delta\Phi = \frac{\mu_0 I X Z}{w}.$$

[2]

- (iv) Use Faraday's law of induction, which led to Maxwell's third law, to show that the induced voltage V between the plates is

$$V = \frac{\mu_0 I v Z}{w}.$$

[1]

- (v) Use the equations in (d)(ii) and (d)(iv) to show that

$$v^2 = \frac{1}{\epsilon_0 \mu_0}.$$

[2]

- (vi) Calculate, to three significant figures, the value of v .

$$v = \dots\dots\dots \text{ms}^{-1} \quad [1]$$

- (vii) Comment on your answer to (vi) and suggest what is happening in the long capacitor.

.....

 [1]

11 Classical physics suggests that all waves need a medium. Einstein's ideas changed that.

(a) A pulse of sound reflects from a cliff that is a distance x from the source of the sound.

- (i) If x is 200.00 m and the speed c of sound is 340.00 ms^{-1} , calculate the time for the sound to travel to the cliff and return (the echo time). Give your answer to five significant figures.

time = s [1]

- (ii) A wind of speed v starts to blow parallel to the shortest line between the sound source and the cliff.

Derive an expression for the echo time t in terms of c , v and x .

[1]

- (iii) Show that, when v is much less than c , an approximate expression for the difference between the echo times with and without the wind is

$$\frac{2xv^2}{c^3}.$$

$(1 + y)$ is approximately equal to $(1 - y)^{-1}$ when y is much less than one.

[2]

- (iv) The speed v of the wind is 20.00 ms^{-1} , the speed c of sound is 340.00 ms^{-1} and the distance x to the cliff is 200.00 m.

Calculate the difference between the echo time for still air and the echo time with the wind.

time difference = s [2]

(b) In the nineteenth century, it was thought likely that there was something filling space that provided the medium for electromagnetic waves.

(i) State the name given to this medium.

..... [1]

(ii) Suppose that, in June, the Earth is not moving relative to this medium but that, in December, movement through the medium creates an effect equivalent to the wind in part (a). Light travels to a mirror 22.0 m away and returns. The time taken is the reflection time. In December, the speed relative to the medium is 60 km s^{-1} in a direction parallel to the line from the source of light to the mirror.

Determine the difference between the reflection time in June and the reflection time in December.

difference between reflection times = s [2]

(iii) Show that the answer to (b)(ii) is three times larger than the period of light with a frequency of 520 THz.

[2]

(iv) Experiments could not detect a medium and Einstein postulated that the speed of electromagnetic waves was invariant.

State the other of Einstein's two postulates in the special principle of relativity.

.....
 [1]

- (c) A muon is a sub-atomic charged particle. Muons are unstable with a half-life of $1.56\mu\text{s}$. Muons are created high in the Earth's atmosphere when cosmic rays interact with atoms. Scientists discovered that far more muons reach the surface of the Earth without decaying than expected. A muon travels 9.17 km down through the atmosphere in $31.2\mu\text{s}$.

- (i) Calculate the speed of the muon.

speed = ms^{-1} [1]

- (ii) One hundred million muons are travelling down at the same speed as in (i) and pass through a point 9.17 km above the surface of the Earth.

Calculate the number of muons that will reach the surface of the Earth undecayed according to classical physics.

number of muons = [3]

- (iii) Use the idea of time dilation to show that the number of muons reaching the surface of the Earth is approximately 6 million. Explain your reasoning as well as showing your calculation.

[4]

[Total: 20]

12 The Boltzmann factor $e^{-\frac{E}{kT}}$ is involved in a vast range of physical, chemical and biological processes. This question is about three examples.

(a) The specific latent heat of vaporisation of water is 2260 kJ kg^{-1} .

(i) State what is meant by the specific latent heat of vaporisation.

.....
 [1]

(ii) The mass of one mole of water is 0.0180 kg .

Calculate the energy required to remove one molecule from liquid water.

energy to remove one molecule = J [2]

(iii) A student attempts to estimate the internal energy of 1.000 kg of liquid water at 100°C by assuming it has no energy at absolute zero. The student makes the following assumptions:

- the specific heat capacity of ice is $2090 \text{ J kg}^{-1} \text{ K}^{-1}$ between 0 K and 0°C
- the specific latent heat of fusion of ice is 33400 J kg^{-1} at 0°C
- the specific heat capacity of liquid water is $4180 \text{ J kg}^{-1} \text{ K}^{-1}$ between 0°C and 100°C .

Calculate the internal energy of 1.000 kg of water at 100°C according to these assumptions.

internal energy = J [3]

- (iv) Using the estimate in (a)(iii), calculate the energy of one molecule of liquid water at 100 °C.

energy of one molecule = J [1]

- (v) The student is surprised that the energy of a molecule is about half that needed to escape.

Explain why the water vaporises despite the molecules seemingly not having enough energy to escape.

.....

 [2]

- (vi) Use the Boltzmann factor to calculate the ratio

$$\frac{\text{number of molecules at } 100\text{ }^\circ\text{C that have the energy to escape}}{\text{number of molecules at } 90\text{ }^\circ\text{C that have the energy to escape}}$$

ratio = [2]

- (b) In the metal silver, every atom contributes a free electron for electrical conductivity. In a semiconducting material, only a very small proportion of atoms contribute free electrons. In a semiconductor, a certain amount of energy is needed to free an electron. As the temperature increases, more electrons are available to conduct electricity.

A piece of semiconductor has a resistance of $30.5\text{ k}\Omega$ at 5°C and $4.8\text{ k}\Omega$ at 25°C . Assume that the resistance is inversely proportional to the number of free electrons.

Use the Boltzmann factor to show that the energy required to free an electron is 0.66 eV .

[4]

- (c) A simple chemical reaction causes a pharmaceutical product to degrade over time. The product is given a 'use by' date which is one year after its date of manufacture. The manufacturers assume that it is stored at a constant 25°C . The energy required to initiate the chemical reaction is 40.7 kJ mol^{-1} .

Show that the 'use by' date will be extended by 15 years if the product is kept in a deep freeze at -18°C .

[3]

- (d) Suggest **one** other physical process where the Boltzmann factor plays a role.

.....
 [1]

(e) Suggest why, in the photoelectric effect, there is a sharp cut-off frequency in emission of electrons rather than the gradual changes in properties with temperature in the examples in parts (a), (b), (c) and (d).

.....
.....
..... [1]

[Total: 20]

- 13 This question is about certainty and chance in physics. In his *Essay on Probability*, Pierre-Simon Laplace (1749–1827) wrote about an imaginary intelligence as follows.

We may regard the present state of the Universe as the effect of its past and the cause of its future. Suppose there is an intelligence which, at a certain moment, would know all forces that set nature in motion and all positions of all items of which nature is composed. If this intelligence were also vast enough to submit these data to analysis, it would embrace in a single formula the movements of the greatest bodies of the universe and those of the tiniest atom. For such an intelligence, nothing would be uncertain and the future, just like the past, would be present before its eyes.

Today, we might think of the intelligence as a powerful computer. The intelligence is known as Laplace’s Demon. Laplace lived a century after Newton’s laws explained the motion of the planets, comets and satellites.

- (a) A new dwarf planet is discovered in a circular orbit of radius 1.5×10^{13} m around the Sun. This radius is 100 times greater than the radius of the Earth’s orbit about the Sun.

- (i) Calculate the time taken, in Earth years, for the dwarf planet to orbit the Sun.

time of orbit = years [3]

- (ii) The mass of the Sun is 27 million times the mass of the Moon.

The Sun is 394 times further away from the Earth than the Moon is from the Earth.

Calculate the ratio

$$\frac{\text{gravitational force of Sun on Earth}}{\text{gravitational force of Moon on Earth}}$$

ratio = [2]

- (iii) Newton’s calculations on the Solar System did not allow for the forces between the planets. Calculating the effect of forces between three bodies is very difficult and has been a challenge for the greatest mathematicians.

Suggest, with reasons, why Laplace’s Demon would find it difficult to analyse the past and predict the future of the Universe.

.....

.....

.....

..... [2]

(b) In the extract, Laplace mentions knowing the position and movement of the tiniest atom.

(i) State what Heisenberg's uncertainty principle says about the position and movement of a particle.

.....
..... [1]

(ii) An electron is known to have a speed of between $0.7c$ and $0.8c$, where c is the speed of light.

Calculate the range Δx with which the position of the electron can be known.

$\Delta x = \dots\dots\dots$ m [2]

(iii) Suggest, with a reason, whether quantum mechanics supports the possibility of Laplace's Demon.

.....
.....
.....
..... [1]

(c) A radioactive source contains 25.00 mg of a radioactive material with a half-life of 400.0 years.

(i) Radioactive decay is random and spontaneous.

Explain what is meant by the word random.

.....
..... [1]

(ii) Calculate the mass of the radioactive material that remains in the source after 10.00 years. Give your answer in mg.

mass = $\dots\dots\dots$ mg [2]

(iii) Given the process is random, explain why you can be sure about the accuracy of your answer.

.....
.....
..... [2]

(d) Two objects at different temperatures are in thermal contact and there is a random exchange of energy between all the atoms in the two objects.

(i) Explain why the net flow of energy is from the hotter object to the colder object.

.....
.....
..... [2]

(ii) In the idea of Laplace’s Demon, there is no distinction between past and future.

Explain why the Demon is **not** consistent with the laws of thermodynamics.

.....
.....
.....
..... [2]

[Total: 20]

Permission to reproduce items where third-party owned material protected by copyright is included has been sought and cleared where possible. Every reasonable effort has been made by the publisher (UCLES) to trace copyright holders, but if any items requiring clearance have unwittingly been included, the publisher will be pleased to make amends at the earliest possible opportunity.

To avoid the issue of disclosure of answer-related information to candidates, all copyright acknowledgements are reproduced online in the Cambridge Assessment International Education Copyright Acknowledgements Booklet. This is produced for each series of examinations and is freely available to download at www.cambridgeinternational.org after the live examination series.

Cambridge Assessment International Education is part of Cambridge Assessment. Cambridge Assessment is the brand name of the University of Cambridge Local Examinations Syndicate (UCLES), which is a department of the University of Cambridge.